

8161350

Robotino Box / CP-MR-B-R34

FESTO

Original operating
instructions



Festo Didactic
05/2023
8161350

Order number: 8161350
Revision Level: 05/2023
Authors: Schober, Weiss, Rajendra
Layout: Frank Ebel
File Name: RobotinoBox-GB-8161350-A001.doc

© Festo Didactic SE, Rechbergstr. 3, 73770 Denkendorf, Germany, 2023



 +49 711 3467-0  www.festo-didactic.com
 +49 711 34754-88500  did@festo.com

Original operating instructions

© 2023 all rights reserved to Festo Didactic SE.



Where only pronouns such as he and him are used in these operating instructions, these pronouns are of course intended to refer to both male and female persons. The use of a single gender (e.g. he, him) should not be construed as gender discrimination; it is intended solely to make the manual easier to read and the formulations easier to understand.

	 CAUTION
	<p>These operating instructions must be available to the user at all times. The operating instructions must be read before commissioning. The safety instructions must be observed. Non-observance may result in severe personal injury or damage to property.</p>

Main document

Associated documents attached:

Safety instructions concerning transport (print/electronic)

Component datasheets (print/electronic)

Circuit diagram (print/electronic)

Contents

1	Safety instructions	5
1.1	Warning notice system	5
1.2	Pictograms	6
1.3	General prerequisites for installing the product.....	8
1.4	General prerequisites for operating the devices	8
2	Intended use	9
3	For your safety	10
3.1	Important information	10
3.2	Qualified persons	11
3.3	Obligations of the operating company	11
3.4	Obligations of the trainees	11
4	Basic safety instructions	12
4.1	General information	12
4.2	Mechanical components	12
4.3	Electrical components	13
4.4	Cyber security	16
4.5	Additional safety instructions	17
4.6	Guarantee and liability	18
4.7	Guarantee and liability for application examples	18
4.8	Transport.....	19
4.9	Protective devices	19
4.9.1	Emergency stop.....	19
4.9.2	Additional protective devices	19
5	Technical data.....	20
6	Scope of delivery and unpacking	23
6.1	Scope of delivery.....	23
6.2	Unpacking	23
7	Design and Function	24
7.1	Transport.....	24
7.2	Setup.....	25
8	External control using Robotino View	28
9	Robotino Autonomous Navigation Quick Start Guide	29
9.1	Quick Info	29
9.1.1	Switching on the Robotino	29
9.1.2	Driving the Robotino	29
9.2	Light tower index.....	30
9.3	Initial Setup.....	31
9.4	Using Robotino after initial set-up	42
10	Festo Fleet Manager.....	43
10.1	Command Center.....	43
10.1.1	Info for Fleet Manager	44
10.1.2	MES System Information	45
10.1.3	Fleet Command Center	46
10.1.4	Out tabs	49

10.2 Preferences	50
10.3 Position Settings	51
10.4 Robotino Settings	52
11 Resetting network settings	53
12 Assembly and Connectors	54
12.1 Installing the optical sensors	54
12.2 Installing the inductive sensor	56
13 Extensions Robotino	57
13.1 Extension with Sick Laserscanner	57
13.2 Extension with workpiece box reception	58
13.3 Interface Robotino.....	61
13.4 Charging kit.....	62
14 Service and cleaning	65
15 Further information and updating	66
16 Disposal	67



1 Safety instructions



1.1 Warning notice system



These operating instructions contain notes that must be observed for your personal safety and in order to prevent property damage. The notes concerning your personal safety are indicated by a safety symbol.

Notes that only concern property damage are not indicated by a safety symbol.

The notes below are listed in order of hazard level.

	 DANGER
	<p>... indicates an imminently hazardous situation that will result in fatal or severe personal injury if not avoided.</p>

	 WARNING
	<p>... indicates a potentially hazardous situation which may result in fatal or severe personal injury if not avoided.</p>

	 CAUTION
	<p>... indicates a potentially hazardous situation that may result in moderate or slight personal injury or severe property damage if not avoided.</p>

	NOTE
	<p>... indicates a potentially hazardous situation that may result in property damage or loss of function if not avoided.</p>

In cases where more than one hazard level applies, the safety note with the highest hazard level will be shown. A safety note may concern both personal injury and property damage.

Hazards that will only result in property damage are indicated with the word "Note".

1.2 Pictograms

This document and the hardware described in it include warnings concerning possible hazards which may arise if the system is used incorrectly.

The following pictograms are used:



Hazard warning



Warning - dangerous electric voltage



Read and observe the operating and safety instructions prior to commissioning.



Switch off the device and unplug the connection for power supply from the plug socket before commencing installation, repair, maintenance or cleaning work.



Warning – hot surface



Warning – hand injuries



Warning – risk of entanglement



Warning – magnetic field



Warning – lifting heavy loads



Electrostatically sensitive devices



Information and/or references to other documentation

1.3 General prerequisites for installing the product

- Festo Didactic products must only be used for the applications specified in their respective operating instructions. Products or components supplied by other manufacturers must only be used if recommended or approved by Festo.
- The products must be transported, stored, installed, assembled, commissioned, operated and maintained properly in order to ensure their safe operation.
- The approved ambient conditions must be observed. The specifications in the relevant operating instructions must be observed.
- The safety equipment must be tested every working day.
- Connecting cables must be checked for damage before each use. In case of damage, they must be replaced.

Connecting cables must correspond to the minimum specifications.

1.4 General prerequisites for operating the devices

General requirements for safe operation of the system:

- In industrial facilities, the national accident prevention regulations must be observed.
- The laboratory or classroom must be overseen by a supervisor.
 - A supervisor is a qualified electrician or a person who has been trained in electrical engineering, knows the respective safety requirements and safety regulations, and whose training has been documented accordingly.

The laboratory or the classroom must be equipped with the following devices:

- An emergency-off device must be provided.
 - At least one emergency-off device must be located inside the laboratory or the classroom, and at least one outside it.
- The laboratory or classroom must be secured so that the operating voltage and compressed air supply cannot be activated by any unauthorized persons, for example by means of:
 - e.g. a keyswitch
 - e.g. lockable shut off valves
- The laboratory or classroom must be protected by residual current devices (RCDs).
 - RCDs with a differential current of ≤ 30 mA, Type B. When operating machinery with unavoidable leakage current, suitable measures must be implemented and documented in the corresponding workplace risk assessment.
- The laboratory or classroom must be protected by overcurrent protection devices.
 - Fuses or circuit breakers
- Devices must not be used if they are damaged or defective.
 - Damaged devices must be barred from further use and removed from the laboratory or classroom.
 - Damaged connecting cables, pneumatic tubing and hydraulic hoses represent a safety risk and must be removed from the laboratory or classroom.
- Safety devices must be checked every working day to ensure that they are fully functional.
- Connecting cables and accessories must be checked for damage before each use.

2 Intended use

Festo Didactic systems and components must only be used:

- For their intended use in teaching and training applications
- When their safety functions are in perfect condition

The components and systems are designed in accordance with the latest technology and recognized safety rules. However, life and limb of the user and third parties may be endangered and the components may be impaired if they are used incorrectly.

The Festo Didactic learning system has been developed and produced exclusively for education and training in the field of automation technology. The training company and/or trainers must ensure that all trainees observe the safety precautions described in these operating instructions.

Training with complex machinery is a highly hazardous activity. The operating company must draw up and document a workplace risk assessment. The trainees must be briefed on all the relevant safety aspects before work commences.

Festo Didactic hereby excludes any and all liability for damages suffered by apprentices, the training company and/or any third parties, which occur during use of the device in situations which serve any purpose other than training and/or vocational education, unless such damages have been caused by Festo Didactic due to malicious intent or gross negligence.

All extensions and accessories must be approved by Festo Didactic, and are only permitted for use for their intended purpose.

The machine fulfils the requirements of the European directives that applied when it was commissioned. Any modification to the machine shall render the manufacturer's CE Declaration of Conformity null and void. The CE Declaration of Conformity must be renewed following each major modification.

3 For your safety

3.1 Important information

Knowledge of the basic safety instructions and safety regulations is a fundamental prerequisite for safe handling and trouble-free operation of Festo Didactic components and systems.

These operating instructions include the most important instructions for safe use of the components and systems. In particular, the safety instructions must be adhered to by all persons who work with these components and systems. Furthermore, all pertinent accident prevention rules and regulations that are applicable at the respective place of use must be adhered to.

	 WARNING
	<ul style="list-style-type: none">• Malfunctions which could impair safety must be eliminated immediately!

	 CAUTION
	<ul style="list-style-type: none">• Improper repairs or modifications may result in unforeseeable operating statuses. Do not carry out any repair or alternation work on components or systems that is not described in these operating instructions.

3.2 Qualified persons

- The product described in these operating instructions is only permitted for operation by persons who are qualified for the task in question in accordance with the operating instructions, especially the safety instructions.
- Qualified persons are defined as persons whose training and experience enables them to recognize risks and avoid potential dangers when working with this product.

3.3 Obligations of the operating company

It is the responsibility of the operating company to ensure that the station is operated safely.

The operating company undertakes to allow only those persons to work with the components and systems who:

- Are familiar with the basic regulations regarding occupational safety, with the safety instructions, and with the accident prevention regulations, and who have been instructed in the use of the components and systems
- Have read and understood the safety chapter and warnings in these operating instructions
- Are qualified to operate the components and systems in question
- Are governed by and trained in suitable organizational measures to ensure safe training

Personnel should be tested at regular intervals to ensure that they are safety-conscious in their work habits.



3.4 Obligations of the trainees

All persons who have been entrusted to work with the components and systems undertake to complete the following steps before beginning work:



- Read the chapter concerning safety and the warnings in these operating instructions
- Familiarize themselves with the basic regulations regarding occupational safety and accident prevention



4 Basic safety instructions



4.1 General information

	 CAUTION
	<ul style="list-style-type: none"> • Trainees must be supervised by an instructor at all times when working with the components and systems. • Observe the specifications included in the technical data for the individual components, and in particular all the safety instructions! • Wear your personal protective equipment (safety goggles, safety shoes). • Never leave objects lying on the top of protective enclosures. Vibrations could cause such objects to fall off.



4.2 Mechanical components



	 WARNING
	<ul style="list-style-type: none"> • Switch off the power supply! <ul style="list-style-type: none"> – Switch off both the operating power and the control power before commencing work on the circuit. – Never reach into the setup unless it is at a complete standstill. – Be aware of potential overtravel times for the actuators. • Risk of injury during troubleshooting! <ul style="list-style-type: none"> – Use a tool such as a screwdriver for actuating sensors.



	 CAUTION
	<ul style="list-style-type: none"> • Risk of burns due to hot surfaces <ul style="list-style-type: none"> – Devices can reach high temperatures during operation, as a result of which they can cause burns if touched. • Measures to take when maintenance is required. <ul style="list-style-type: none"> – Allow the device to cool off before commencing work. – Use suitable personal protective clothing, e.g. safety safety gloves.



	 CAUTION
	<ul style="list-style-type: none"> • Rotating drive rollers and drive belts <ul style="list-style-type: none"> – Risk of injury to the fingers – Only carry out assembly work in this area when the device is switched off – Avoid penetration of small parts – Cable routes in the area of rotating parts must be laid securely • Collision with robots <ul style="list-style-type: none"> – Danger of being crushed, sheared or pinched – Do not carry out any dangerous work in the area of action of the robot. Robot can make unforeseen movements. – Do not stay in the area of the robot, who can be avoided. – Expect the robot to behave unpredictably.

4.3 Electrical components

	 WARNING
	<ul style="list-style-type: none"> • Risk of fire due to use of unsuitable power supply <ul style="list-style-type: none"> – If a device is connected to an unsuitable power supply, this can cause components to overheat, leading to a breakout of fire. – Always use limited power supplies (LPSs) for all the connections and terminals on the electronics modules.

	 CAUTION
	<ul style="list-style-type: none">• Always ensure that your connecting cables are designed for use with the electrical connections in question.• When laying connecting cables, make sure they are not kinked, sheared or pinched.• Make sure that connecting cables are not subjected to continuous tensile loads.• When replacing fuses, always use specified fuses with the correct current rating and tripping characteristics.• Safe operation of the device is not possible in the event of any of the following circumstances:<ul style="list-style-type: none">– Visible damage– Malfunction– Inappropriate storage– Incorrect transport– Switch off the power supply immediately.• Protect the device to prevent it from being restarted accidentally.

	 CAUTION
	<ul style="list-style-type: none">• Hot assembly groups<ul style="list-style-type: none">– Risk of burns from hot parts– Installation of optional electronic modules only when the device has cooled down– Only carry out work on electronic modules at an ESD workstation. Use suitable ESD tools

	 CAUTION
	<ul style="list-style-type: none">• Electrostatic discharge<ul style="list-style-type: none">– Unpredictable behavior of the robot– Operation should take place on dissipative floor– Avoid static charging with suitable shoes and clothing

	NOTE
	<ul style="list-style-type: none">• Device destruction due to short circuit<ul style="list-style-type: none">– The device contains housing openings for cooling. Make sure that no electrically conductive parts penetrate, e.g. by pinching off wire ends.

	NOTE
	<ul style="list-style-type: none">• Device destruction due to incorrect operating voltage<ul style="list-style-type: none">– Note the voltage range of external devices.– Compare the supply voltage with the voltage provided.– Note the current consumption of the external device– Pay attention to the polarity– Make sure that the line is laid without crushing, shearing, cutting or other mechanical hazards.– Secure the line sufficiently



4.4 Cyber security

Festo Didactic offers products with security functions that aid the safe operation of plants, systems, machines and networks. In order to protect plants, systems, machines and networks from cyber threats, a comprehensive security concept must be implemented and continuously updated. Festo's products and services only constitute one part of such a concept.

The customer is responsible for preventing unauthorized access to their plants, systems, machines and networks. Systems, machines and components should only be connected to a company's network or the Internet if and as necessary, and only when the suitable security measures (e.g., firewalls and network segmentation, defense-in-depth) are in place. Failure to ensure adequate security measures when connecting the product to the network can result in vulnerabilities which allow unauthorized, remote access to the network – even beyond the product's boundaries. This access could be abused to incur a loss of data or manipulate or sabotage systems. Typical forms of attack include but are not limited to: Denial-of-Service (rendering the system temporarily non-functional), remote execution of malicious code, privilege escalation (executing malicious code with higher system privileges than expected), ransomware (encryption of data and demanding payment for decryption). In the context of industrial systems and machines this can also lead to unsafe states, posing a danger to people and equipment.

Furthermore, Festo's guidelines on suitable security measures should be observed. Festo products and solutions are constantly being developed further in order to make them more secure. Festo strongly recommends that customers install product updates as soon as they become available and always use the latest versions of its products. Any use of product versions that are no longer supported or any failure to install the latest updates may render the customer vulnerable to cyber-attacks.

Support Festo in ensuring your continued safety. Please report any security findings to the Festo Product Security Incidence Response Team (PSIRT) in German or English language, by email to psirt@festo.com or online contact form at <https://www.festo.com/psirt>.

 WARNING	
	<ul style="list-style-type: none"> • Unsecure operating conditions due to software tampering <ul style="list-style-type: none"> – Forms of software tampering (e.g. viruses, Trojans, malware and worms) can lead to unsecure operating conditions in your system, which may in turn lead to severe or fatal injury or property damage. – Keep your software up to date. – Integrate the automation and actuator components into an overarching and comprehensive industrial security concept for the installation or machine in question that is in line with the latest technological developments. – Make sure that all the products you have installed are incorporated into your overarching industrial security concept. – Use suitable measures, such as a virus scanner, to protect files save on exchangeable storage media from malware.

4.5 Additional safety instructions

General requirements for safe operation of the devices:

- Do not lay cables over hot surfaces.
 - Hot surfaces are identified with a corresponding warning symbol.
- Maximum permissible current loads for connector cables and devices must not be exceeded.
 - Always compare the current ratings of the device, the cable and the fuse to ensure that they match.
 - If they do not match, use a separate upstream fuse in order to provide appropriate overcurrent protection.
- Devices with a grounding terminal must always be grounded.
 - If a ground terminal (green-yellow laboratory socket) is available, it must always be connected to protective ground. The protective grounding must always be connected first (before voltage) and disconnected last (after disconnecting the voltage).
- The device is not equipped with a built-in circuit unless otherwise specified in the technical data.

	 WARNING
	<ul style="list-style-type: none">• This product is designed for use in industrial environments, and may cause malfunctions if used in domestic or small commercial environments.

4.6 Guarantee and liability



Our General Terms and Conditions of Sale and Delivery shall apply at all times. These shall be made available to the operating company no later than upon conclusion of the sales contract. Guarantee and liability claims resulting from personal injury and/or property damage are excluded if they can be traced back to one or more of the following causes:

- Use of the equipment for purposes other than its intended use
- Improper installation, commissioning, operation or maintenance of the system
- Operation of the system with defective safety equipment, or with improperly attached or non-functional safety equipment and protective guards
- Non-compliance with directions included in the operating instructions with regard to transport, storage, installation, commissioning, operation, maintenance and setup of the system
- Unauthorized modifications to the system
- Improperly executed repairs
- Disasters resulting from the influence of foreign bodies and acts of God
- Dust generated during construction work must be kept away from the system (use coverings). See the Environmental Requirements section (contamination level) for more details.

4.7 Guarantee and liability for application examples

The application examples are not legally binding, and we cannot guarantee their completeness in terms of their configuration, their equipment or any events that may occur. The application examples are not representations of any specific customer solution; they are merely intended to illustrate typical tasks for which the product in question could be used. You bear the responsibility for ensuring that the products described here are operated properly. These application examples do not in any way relieve you of your responsibility to ensure that the system is handled safely when it is being used, installed, operated or maintained.

4.8 Transport

	 WARNING
	<ul style="list-style-type: none"> • Danger due to tipping over <ul style="list-style-type: none"> – Suitable packaging and transport equipment must be used when transporting the station.

	NOTE
	<p>Station contains delicate components!</p> <ul style="list-style-type: none"> • Take care not to shake during transportation • The station is only permitted for installation on solid, non-vibrating surfaces. • Make sure that the ground underneath the station has sufficient load-bearing capacity.

4.9 Protective devices

In order to reduce risks, this machine contains guards to prevent access to dangerous areas. These guards must not be removed or tampered with.

4.9.1 Emergency stop

Every station contains an emergency stop mushroom actuator. All the emergency stop actuators in the system are interconnected. The emergency stop signal shuts off all the actuators. Operator confirmation is required to restart the system; there is no automatic restart.

4.9.2 Additional protective devices

The individual components, such as the power supplies and the controllers, possess built-in safety functions such as short-circuit protection, overcurrent protection, overvoltage protection and thermal monitoring. If necessary, consult the instruction manual for the device in question for more information.

5 Technical data

Parameter	Value
Electrics	
Operating voltage	24 V
Power supply system	2 pieces of integrated accus, 12V
Middle power	Approx. 50 W
Ambient conditions	
Operating environment	Use inside building only
Ambient temperature	5°C ... 40°C
Rel. air humidity	80% up to 31°C
Pollution degree	2, Dry, non-conductive contamination
Operating height	Up to 2000 m above NN (sea level)
Noise emission level	$L_{pA} < 70$ dB
Certification	
CE marking in accordance with:	Machinery Directive EMC Directive RoHS Directive
EMC environment	Industrial environment, Class A (in acc. with EN 55011)
Subject to change	

Parameter	Value
Dimensions	
Diameter	47 cm
Height without tower	32 cm
Height with tower	78,5 cm
Height with tower and transport unit	123 cm
Width with tower and transport unit	52 cm
Mass	
Robotino with 2 St accus	20 kg
Tower	3 kg
Segment table	1,6 kg (3+1,6 kg = 4,8 kg)
Transport unit	Ca. 10 kg
Max. live load on Robotino basic unit	30 kg
Max. live load on segment table	25,2 kg
Max. mass: 20 kg + 30 kg	50 kg
Speed	
Wheel diameter	125 mm
Wheel extent	$125 + \pi = 393$ mm
Max. drive	93,5 1/min
Max. extent speed	$393 \text{ mm} * 93,5 \text{ 1/min} = 36745 \text{ mm/min} = 36,7 \text{ m/min} = 0,6 \text{ m/sek.}$
Max. speed	$36,7 \text{ m/min} * \cos(30^\circ) = 31,8 \text{ m/min} = 0,52 \text{ m/sek}$
Shear force	
measured	150N
Tilting	
	No tipping possible due to additional stopper
Kinetic energy	
	$E = \frac{1}{2} * m * v^2 = 0,5 * 50 \text{ kg} * (0,52 \text{ m/s})^2 = 6,8 \text{ J}$
Fall down of payload	
	$E = m * g * h = 25,2 \text{ kg} * 9,81 \text{ m/s}^2 * 0,785 \text{ m} = 194 \text{ J}$
Subject to change	

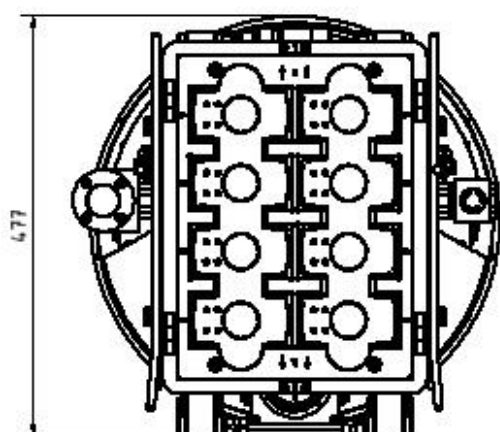
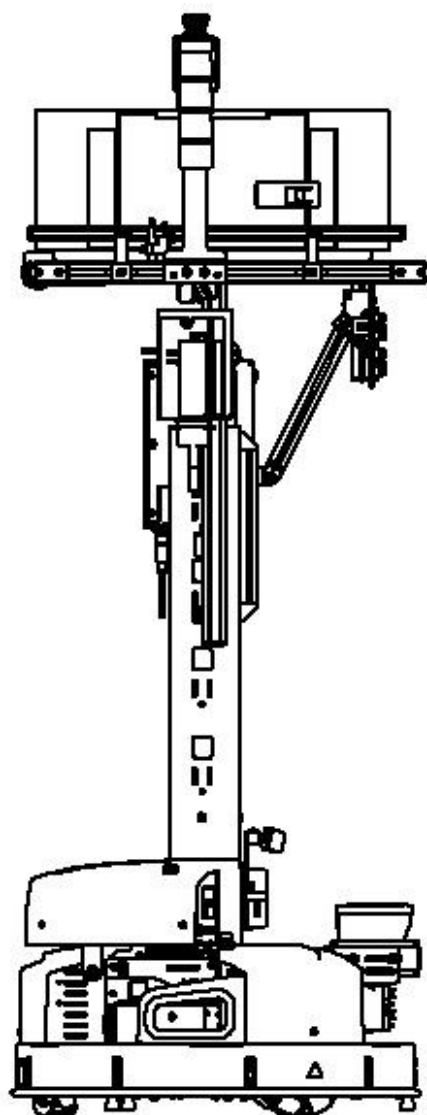
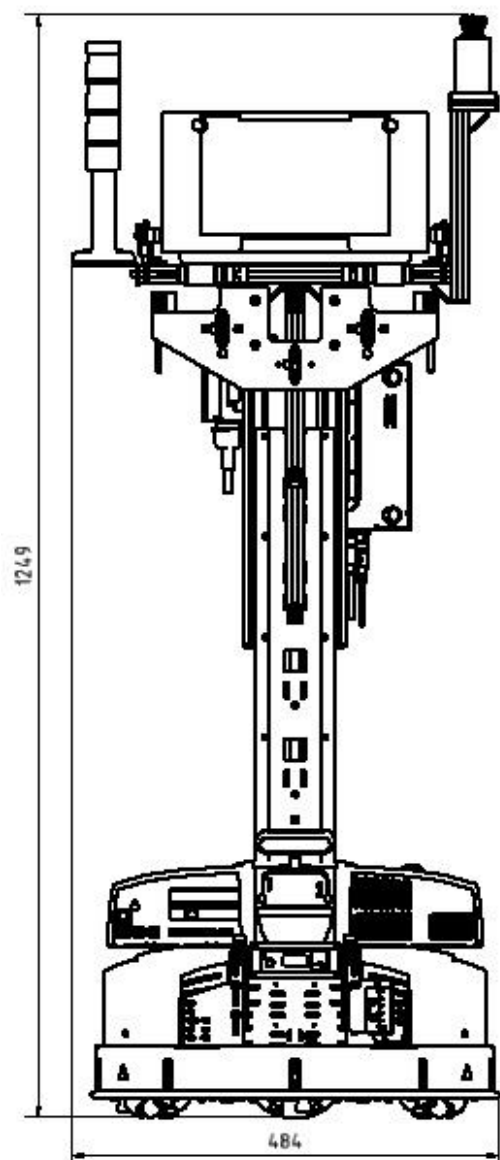

Illustration similar

6 Scope of delivery and unpacking

6.1 Scope of delivery



Please, check if scope of delivery does correspond to the shipping note. The carrier and Festo Didactic are to be notified immediately in case of missing items.



6.2 Unpacking



Carefully remove the padding material when unpacking the Robotino. When unpacking the Robotino, make sure that none of the Robotino assemblies have been damaged. Check the Robotino for any possible damaged once unpacked. Always seize the Robotino by the two handles to avoid any damage to the command control unit, electronics and collision protection sensor. The carrier and Festo Didactic are to be notified immediately of any damage.

7 Design and Function

7.1 Transport

	 WARNING
	<ul style="list-style-type: none"> • Heavy training device <ul style="list-style-type: none"> – Moving heavy machinery / machine parts damages the musculoskeletal system – When delivering the stations, special care must be taken that heavy machines / machine parts are only transported with a suitable industrial truck. The weight of a station can be up to 100 kg. – Use suitable means of transport – Only move the machines / machine parts on the intended ones support points – Note the load suspension point – Frequent lifting and carrying can lead to back pain – Avoid lifting and carrying the device frequently – Only lift the device by the handles – If necessary, transport the device with a second person

	 WARNING
	<ul style="list-style-type: none"> • Securing transit routes <ul style="list-style-type: none"> – The supply routes must be cleared prior to transport, and must be suitable for the forklift truck to pass through. If necessary, warning signs or barrier tape must be set up to keep the routes clear. • Caution <ul style="list-style-type: none"> – When opening transport boxes, care must be taken to ensure that any additional components delivered in the same box, such as computers, do not fall out.

	 WARNING
	<ul style="list-style-type: none"> • Danger of crushing for hands/feet <ul style="list-style-type: none"> – It is not permitted to grip onto or under the feet when handling the machine, as there is an increased risk of hands or feet getting crushed or trapped in these areas. – When setting down the station, make sure no persons have their feet under the machine's feet.

NOTE	
	<ul style="list-style-type: none"> – When opening the transport box, any additional components must be secured to prevent them from falling out, and removed first. – Once this is done, the transport box can be removed/opened up fully, and the station can be taken out and moved to its intended location. – Care must be taken with all components projecting from the machine, as sensors and similar small parts can easily be damaged if the machine is not transported correctly. – Check that all the profile connectors are seated correctly using a size 4 – 6 Allen key. Unavoidable vibrations can loosen the connectors during transport.

7.2 Setup

When unpacking the Robotino, remove the hard foam insert from the transport packaging. When removing the Robotino, make sure that no parts are damaged. Always hold the Robotino by the two handles to avoid damaging the control unit, the electronics and the collision protection sensor. After unpacking, the Robotino must be checked for possible damage. Damage must be reported to the freight forwarder and Festo Didactic immediately.



Please follow these instructions for initial setup of your Robotino.



1. Unpack

Carefully remove the padding material of the transport box when unpacking the Robotino. Make sure that none of the Robotino assemblies have been damaged. Always seize the Robotino by the two handles to avoid any damage to the control unit, electronics and collision protection sensor.



Check the Robotino for any possible damaged once unpacked. The carrier and Festo Didactic are to be notified immediately of any damage.

	 WARNING
	<ul style="list-style-type: none">• Rotating drive rollers<ul style="list-style-type: none">– Risk of crushing if your fingers or hand are pulled in– Do not reach into the area of the drive rollers when the device is switched on.– Only lift the device by the handles– Do not remove the cover of the drive rollers

	 WARNING
	<ul style="list-style-type: none">• Falling payload<ul style="list-style-type: none">– Falling payload can lead to severe impact or crush injuries– Avoid staying in the Robotino's area of activity– Ensure that the payload is securely fixed.– Make sure that no bumps or barriers can cause the Robotino to tip over.• Risk of tipping over<ul style="list-style-type: none">– Risk of tipping when the center of gravity is high– When assembling with a tower, mount the spacers on the base plate of the robot– Attach external components to the robot against falling– Provide protection against falling goods

2. Start

Start Robotino by pressing the main power switch on the control unit for about 3 seconds.



The start up takes up to 30 seconds.

3. Connect

Remove the supplied mini access point from its packaging and plug it into one of the six available USB sockets in the Robotino control unit.



Once the Mini-Accesspoint is recognized by the operating system a WLAN access point is initialized and a web server is started that provides the web interface for the control of Robotino. By default the network name (SSID) of the access point corresponds to the specification on the nameplates of Robotino. One nameplate is located right next to the power supply connector. Connect your SmartPhone, tablet or notebook with the specified network (e.g. Robotino.301.064). The network is secured with the password "Robotino". Enter this password when you are prompted. The initialization of the first connection may take longer (up to 60 seconds).

Open an Internet browser and enter the IP address of Robotino. The Robotino web interface is shown in your Internet browser. The IP address upon delivery (172.26.1.1) can also be found on the nameplate.

4. Test

To test your Robotino, switch to web interface page Program and start one of the demonstration programs. Alternatively, you can switch to web interface page Control to manage the movement of Robotino individually. Make sure that a sufficiently large clear area is available for the movement of Robotino.

5. Turn off

Press the main switch of Robotino for about 3 seconds to turn off the system.

8 External control using Robotino View

To control your Robotino using the graphical programming system Robotino View proceed as follows.

1. Setup
Execute the latest setup of Robotino View. You find the download link to the latest setup of Robotino View on the homepage of Festo Didactic. Just look for "Festo Didactic Robotino View" in your internet search engine.
2. Connect to network
Connect your PC or notebook via WLAN to your Robotino.
3. Run Robotino View
Execute Robotino View on your PC or notebook.
4. Connect Robotino View
Enter the IP address of your Robotino into the edit box in the toolbar of Robotino View. As default the IP address is 172.26.1.1.

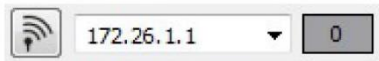

Press Enter or alternatively, click on the button with the antenna icon directly to the left of the edit box to establish the connection.

Once the connection has been successfully initialized, the button and the edit box will be disabled and the link quality is displayed in the field next to the input field of the IP address. A value of 100 corresponds to the best link quality.



5. Programming with Robotino View
Open one of the installed samples of Robotino View from directory examples. You find this directory in the installation directory of Robotino View. Alternatively, you are able to create your own simple control program. For that use the help system of Robotino View.
6. Start control
Press the button for starting the main program to use the current program in Robotino View to control the associated Robotino.



Make sure that a sufficiently large clear area is available for the movement of Robotino.

7. Finish control
Press the button for stopping the control program. The control is terminated immediately.



9 Robotino Autonomous Navigation Quick Start Guide

9.1 Quick Info

9.1.1 Switching on the Robotino

	HINWEIS
	<p>Make sure battery is fully charged Slot 1 has a charged battery</p>

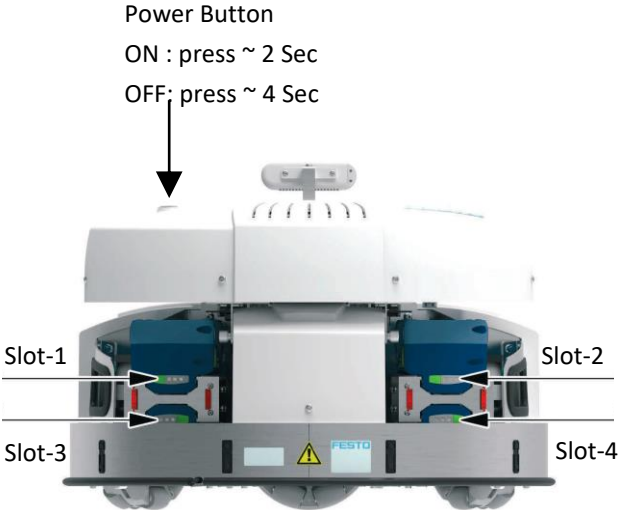
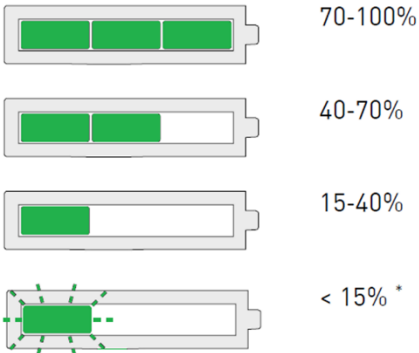

9.1.2 Driving the Robotino

	HINWEIS
	<p>Make sure emergency button is released No obstacles in front of the laser scanner Reset button light is off, if flashing, release emergency and press reset button</p>

Release emergency





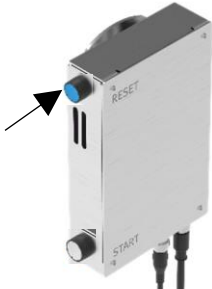



Reset emergency



Drive



9.2 Light tower index

	Status		Description
		Red On	Error during executing a task
		Red flashing	Robotino not localized
		Orange on	Obstacle detected in laser safety zone
		Orange flashing	Emergency stop active, release emergency and reset to resume
		Green on	Idle and ready to receive task
		Green flashing	Busy executing a task

9.3 Initial Setup

Step 1:

Press Button to turn On the Robotino.



Step 2:

Launch the Robotino Factory application.



Step 3:

Click on the connect dialog of the application.

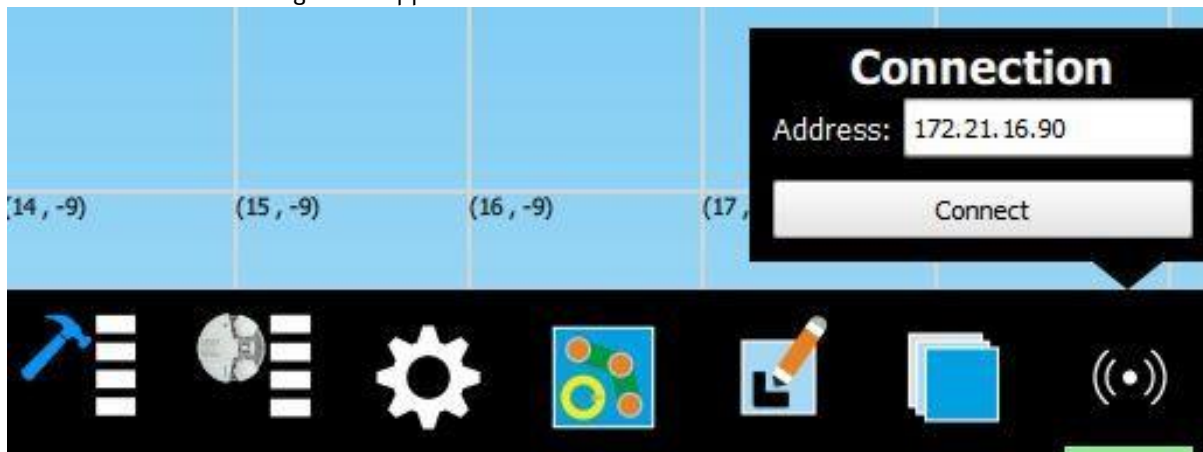

Step 4:

Enter the IP address of the Master Robotino (When working with multiple Robotino).



Step 5:

Click on the connect button and the connection to the Master Robotino is established.

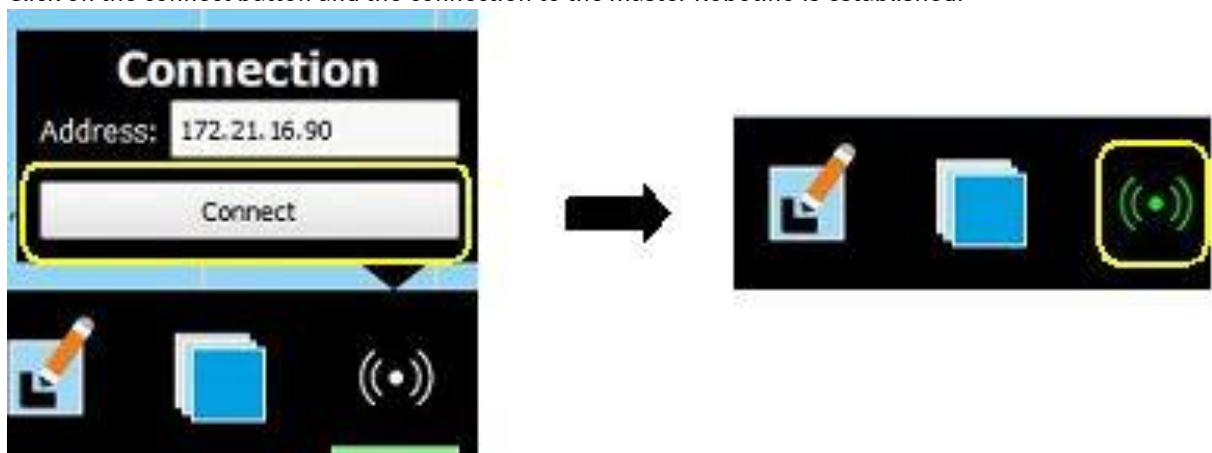

Step 6:

Click on the map manage button and then on create new map to make a new map of the driving area.

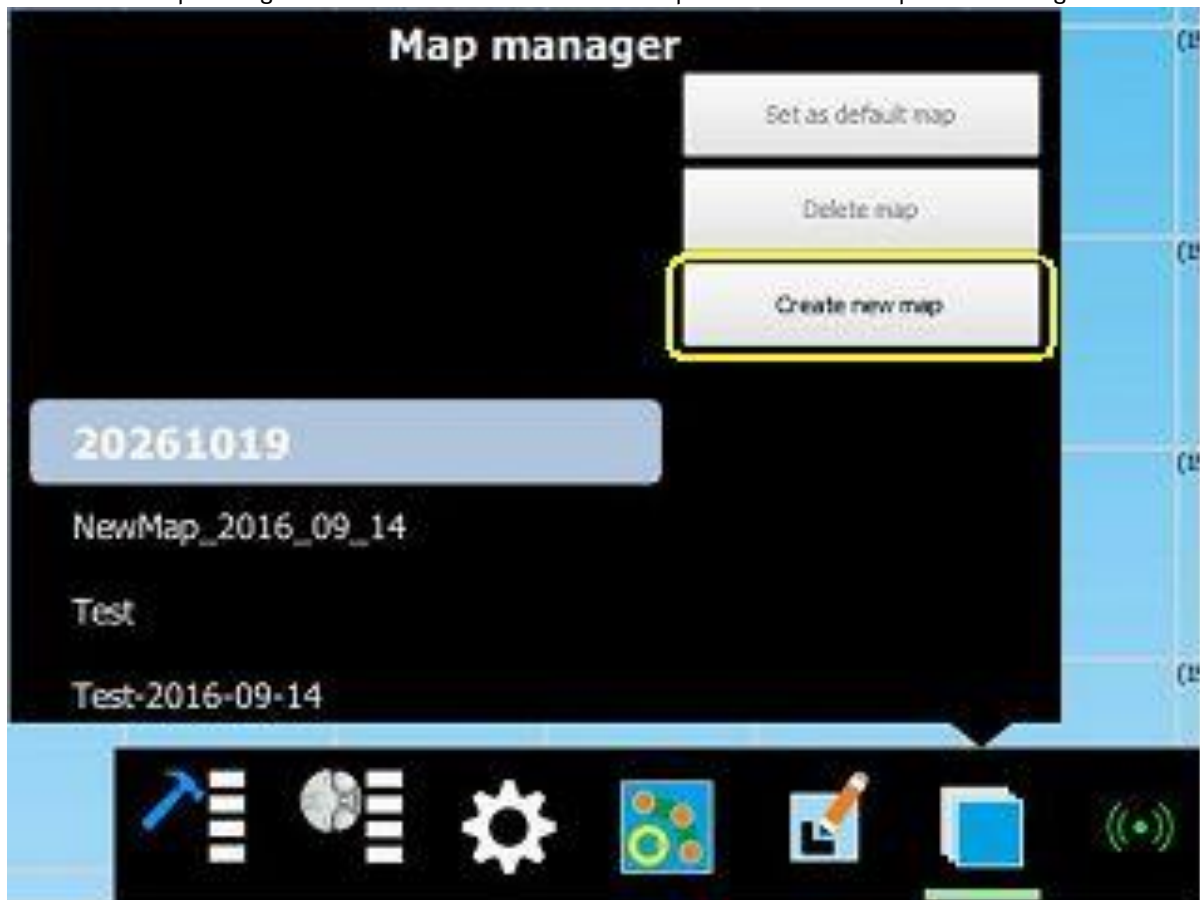
**Trouble shooting Note:**

If you don't see the map getting built, check if the laser scanner power and serial cable are connected.

Step 7:

Drive the Robotino slowly using the joystick (Logitech F710 Controller)



Logitech F710 wireless controller

Step 8:

When all the desired area is covered in the map, click on check mark to save the map.

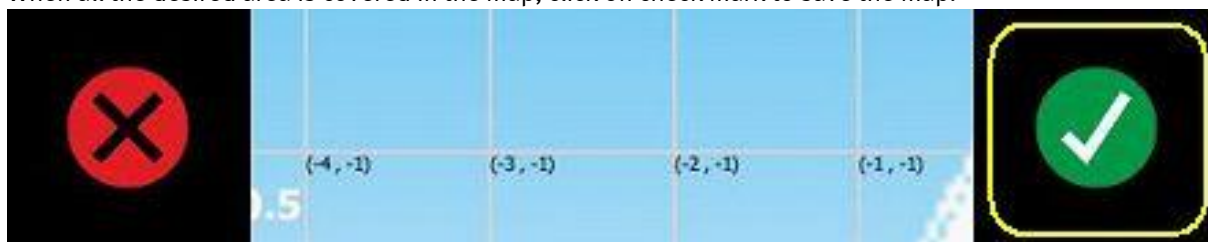

Step 9:

Once the map is available we need to teach the position of the station. Select the pose and path editor button.



Step 10:

Select the add pose button and add the required positions on the map. Once the positions are add, conclude by clicking on the save button.

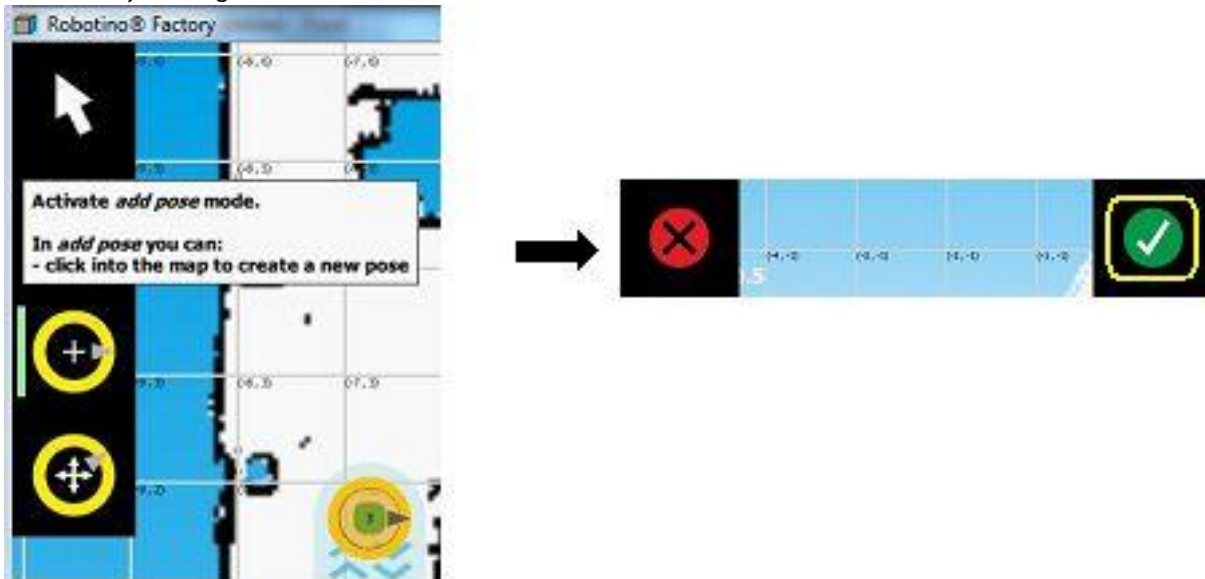

Step 11:

Selected the move pose mode to adjust the added position and orientation on the map. Once the positions are modified, conclude by clicking on the save button.

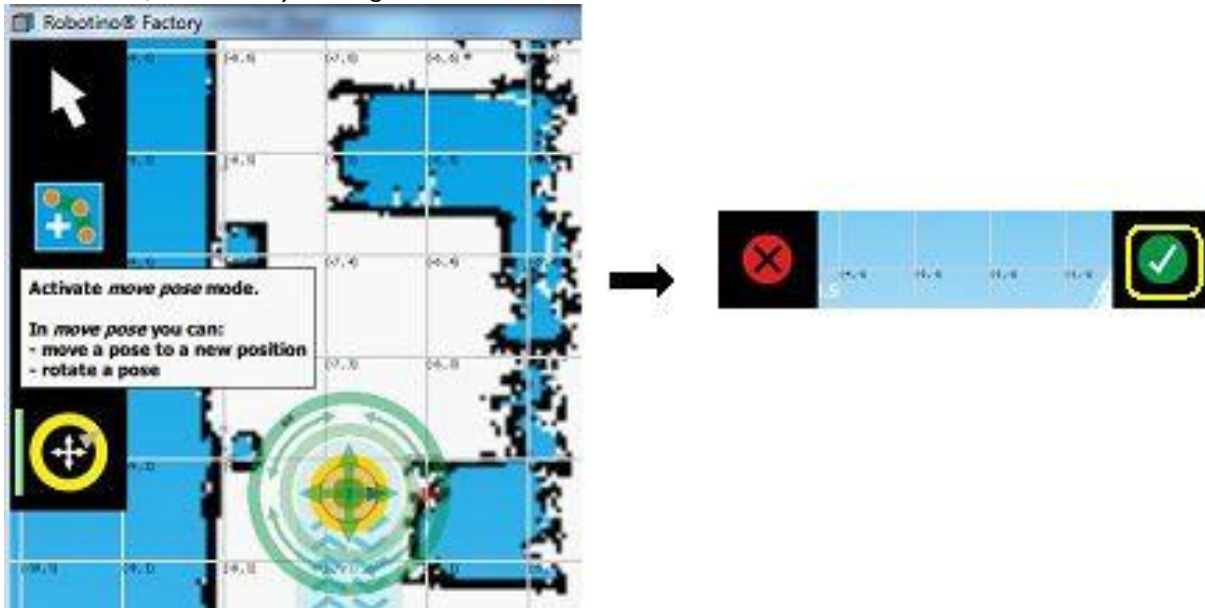

Step 12:

Select the path mode to draw a new path between the positions.

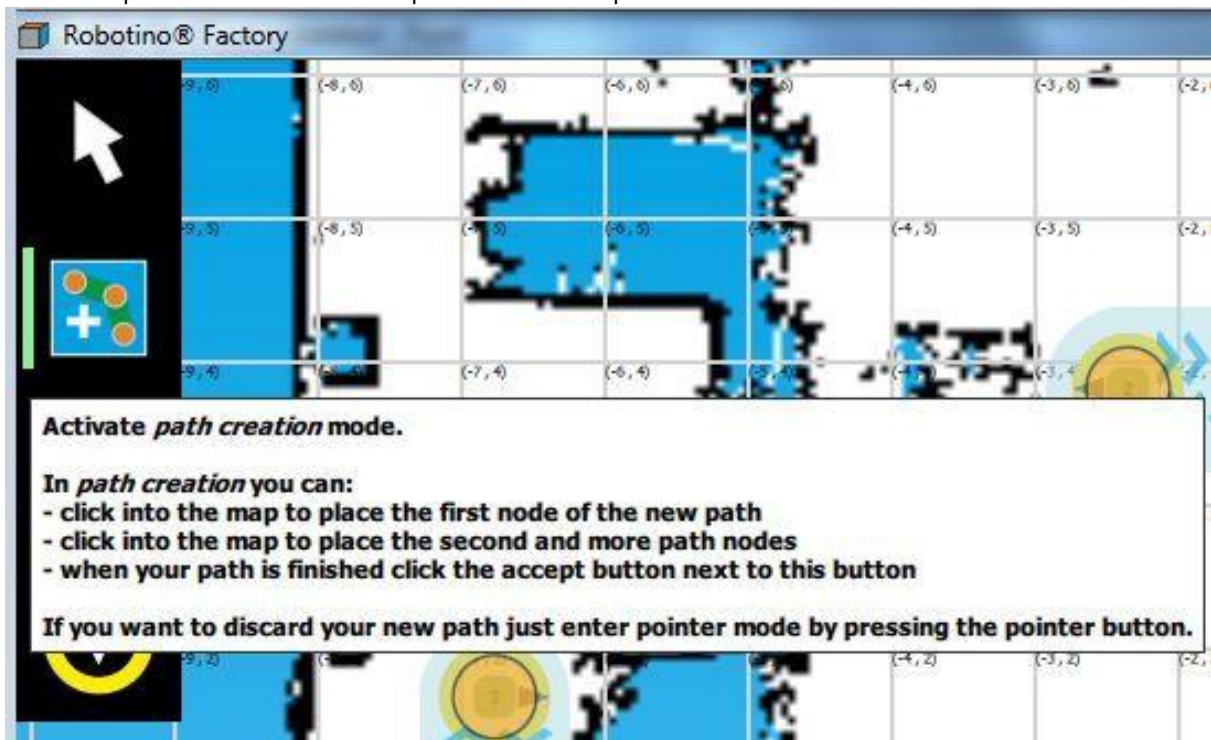

Step 13:

Draw the path between the positions and when we want to conclude the path click on the save path button.

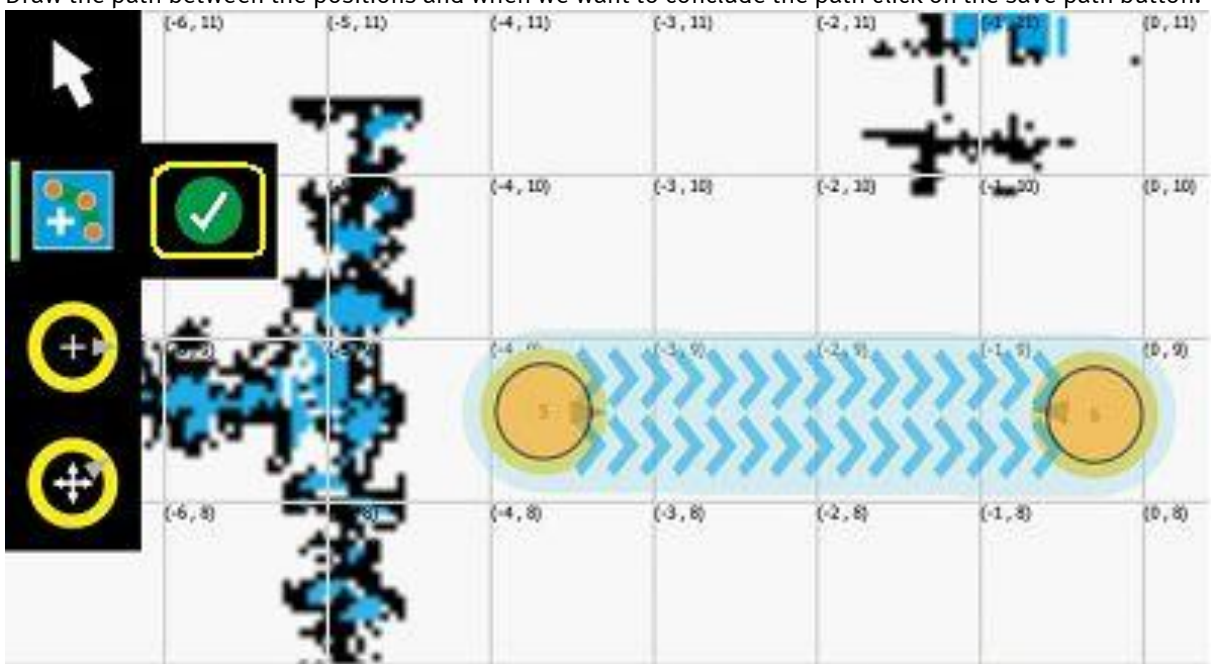

Step 14:

After all the required paths are drawn finish by clicking the save button.

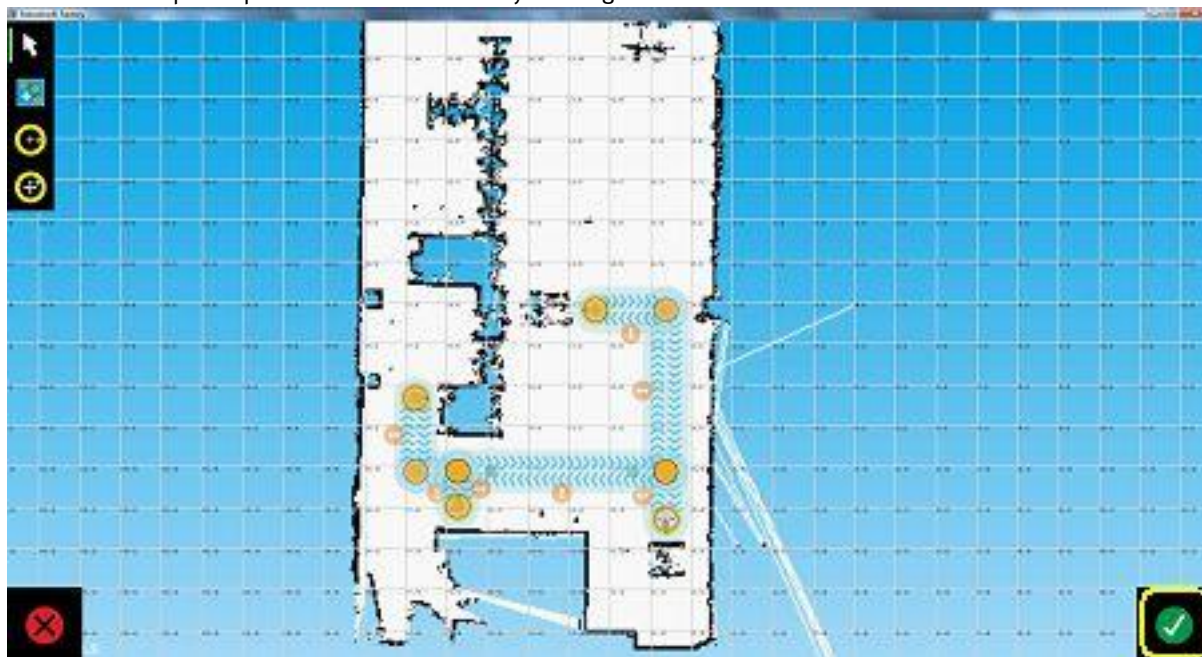

Step 15:

If it is required to edit the path nodes or make a path as one/two way path, select the active pointer mode.

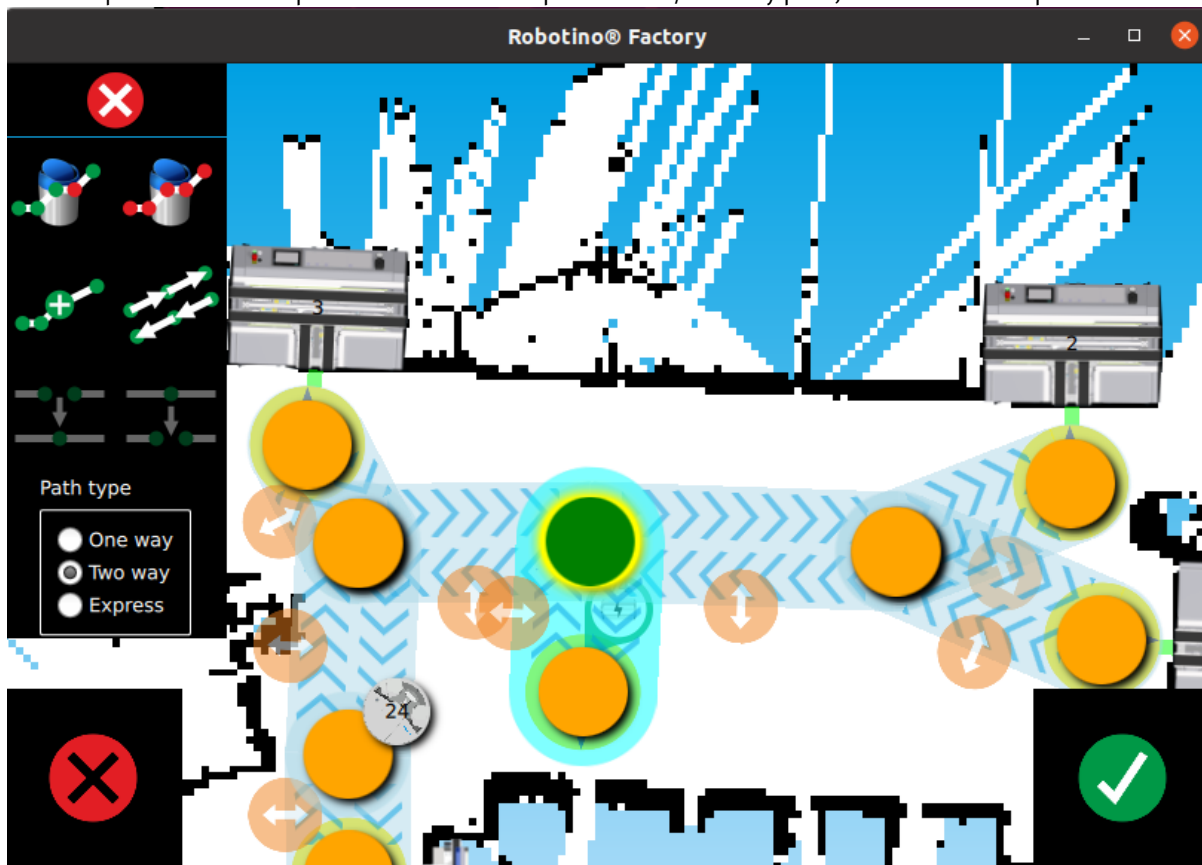

Step 16:

Insert the correct station and link it to the appropriate position.

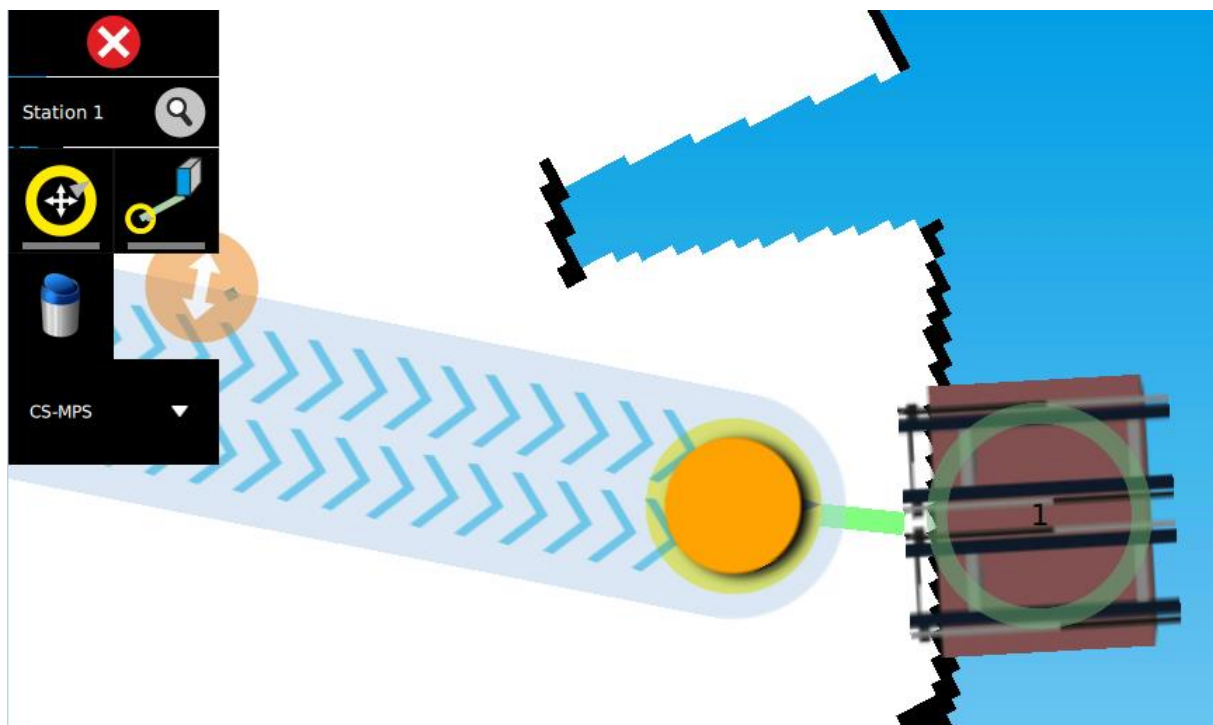

Step 17:

When you're done, the map will then look like this:

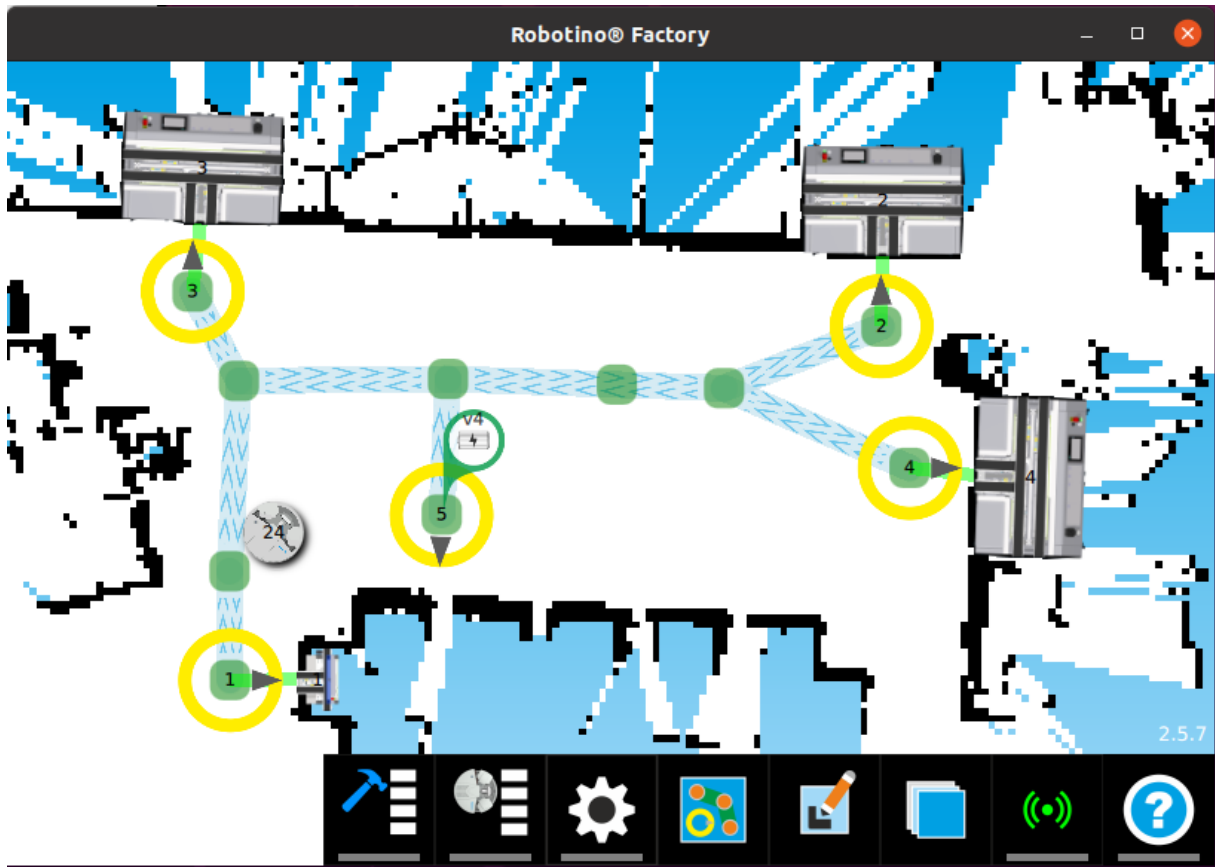

Step 18:

When all the positions are taught launch the “Festo Fleet Manager” application.

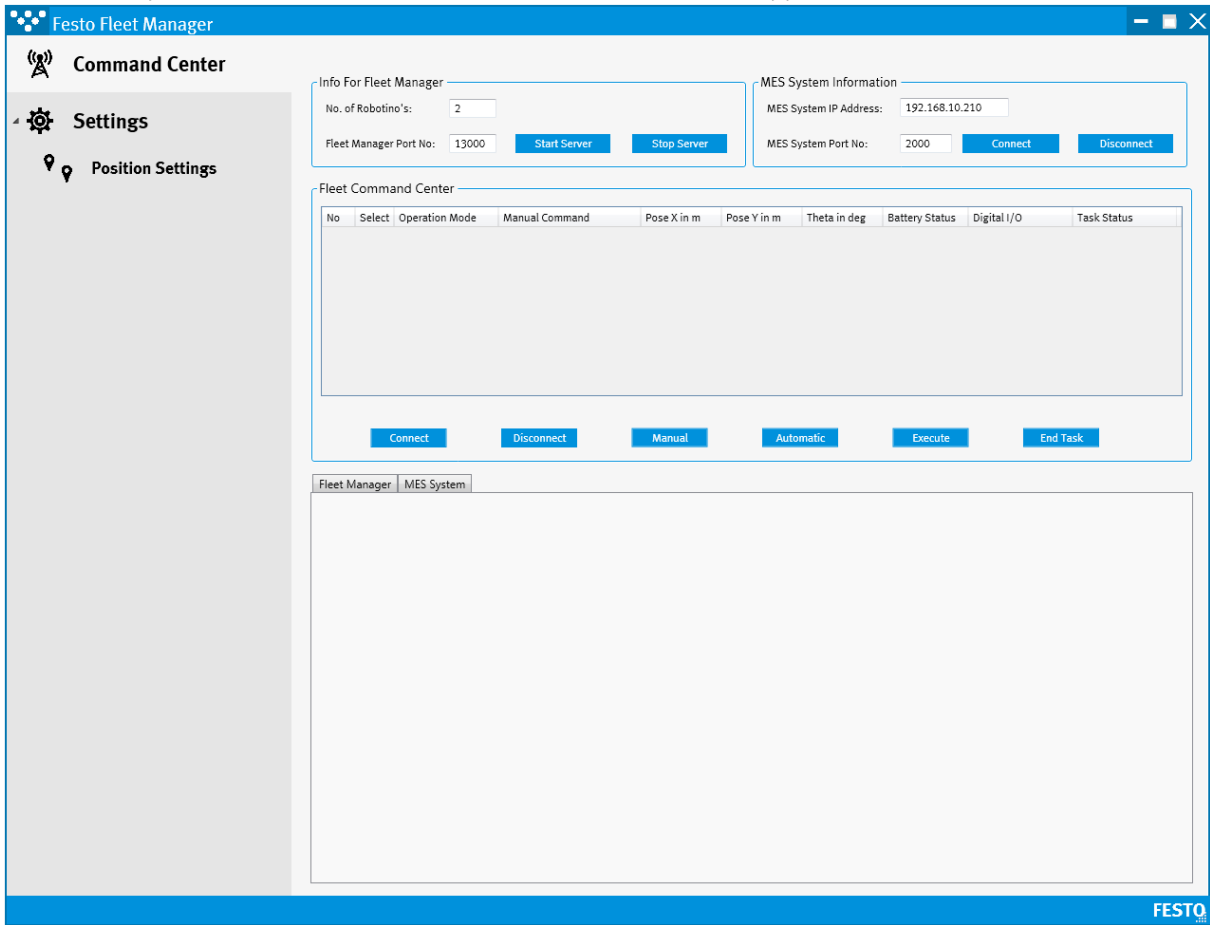

Step 19:

1. Click on “Position Settings”
2. Enter the no. of taught positions and all the information related to it.
3. Click on “Apply” to save the entries.

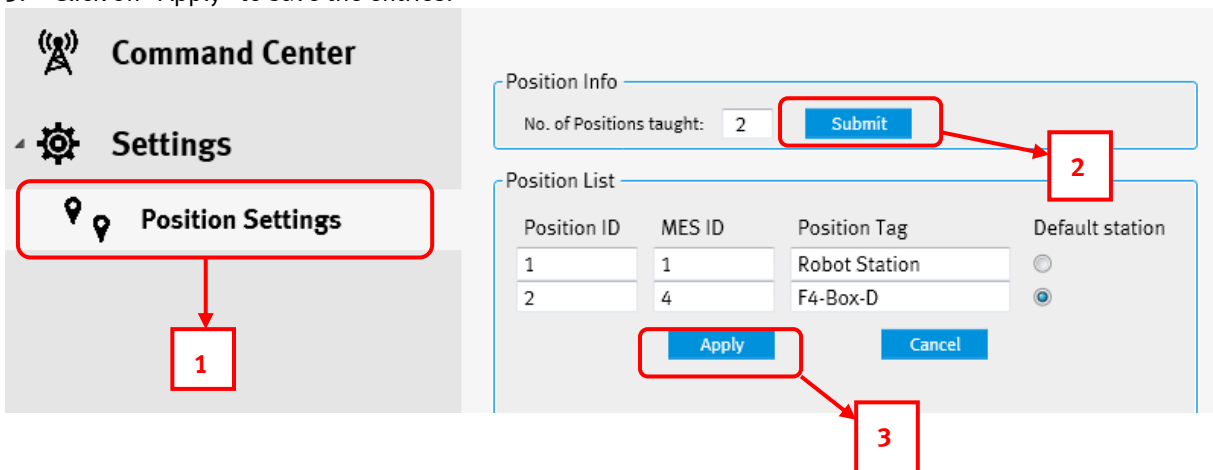

Step 20:

To start the Robotino to take orders from the MES4 system and automatically deliver the order

1. Select “Command Center” on the left tab.
2. Then on “Start Server” in the Info for Fleet Manager group
3. Then on “Connect” in the MES system information group.

When all of this is done the Robotino will automatically process the orders from the the MES4 system.

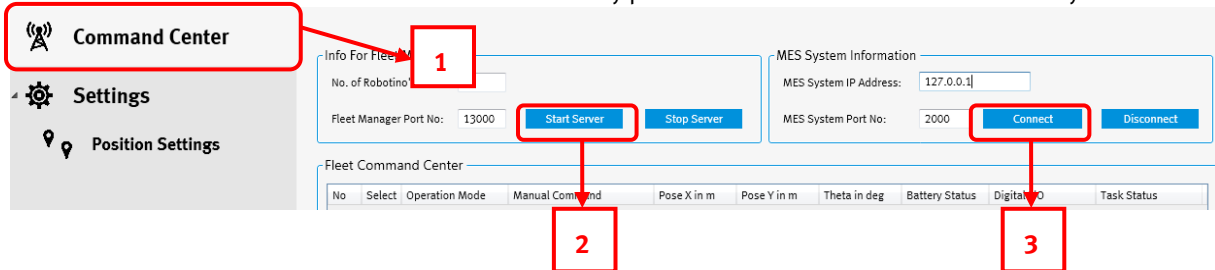

9.4 Using Robotino after initial set-up

Step 1:

Turn On the Robotino.



Step 2:

Wait for the flashing green light to stop.

Step 3:

Launch the Robotino factory application.

Step 4:

Open the map management dialog and select the right map from the list and set it as the default map.

Step 5:

Drive the Robotino till the flashing red light turns off.

Step 6:

Launch Fleet Manager Application

10 Festo Fleet Manager

Festo fleet manager is software to manage logistic tasks done by a single or a fleet of Robotino. The software bridges the logistic operation between the MES software and Robotino.

The overall view of the user interface is shown in the Fig. 1.

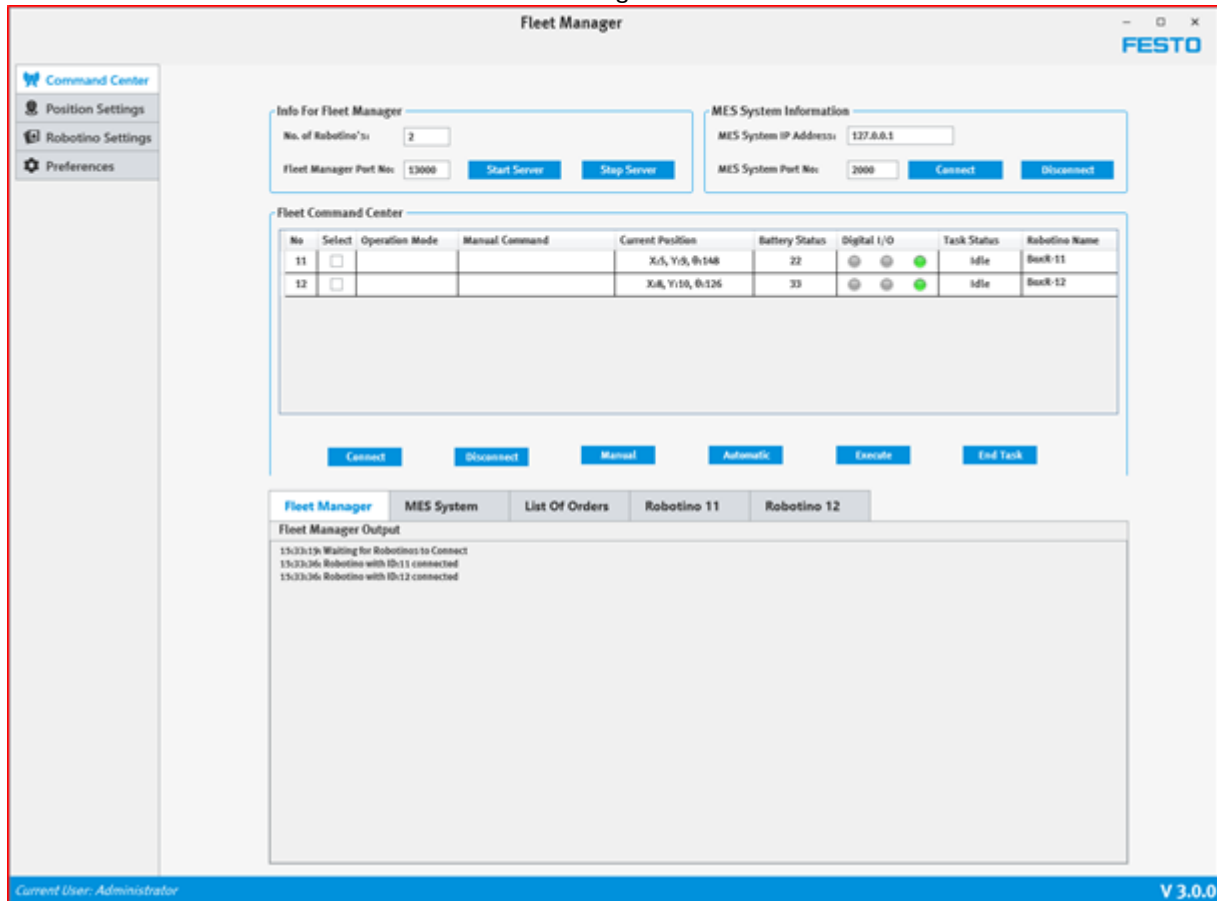

Figure 1: Main Window for controlling Robotino

The software has two four sections

- Command Center
- Position settings
- Robotino settings
- Preferences

10.1 Command Center

Here in the command center individual or multiple Robotino can be assigned logistic tasks, a detailed explanation of the command center is given in the following section.

10.1.1 Info for Fleet Manager

Contains information related to size of the fleet to be managed and the communication port.

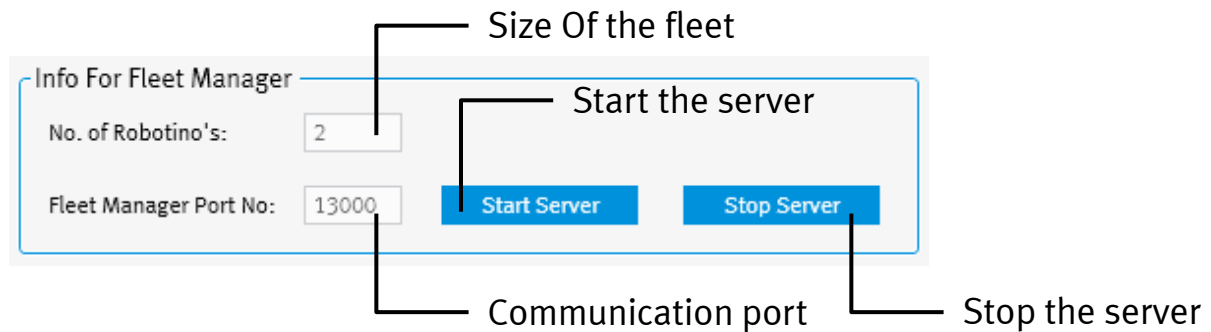

Figure 2: Fleet Manager Configuration Information

Steps to establish connection between Robotino and Fleet Manager.

1. If the server is running, stop the server.
2. Enter the no. of Robotino used with fleet manager.
3. Enter a valid free port number over which the fleet manager can communicate with the Robotino. (same must also be configured on the Robotino)
4. Click on the “Start Sever” button.

Note 1:

The “Stop Server” button is used to end all communication between Fleet Manager and Robotino, any connected Robotino will be disconnected.

Note 2:

All the information regarding connection between Fleet Manger and Robotino are displayed in the “Fleet Manager” output tab.

Once the communication is established, the following output is displayed.

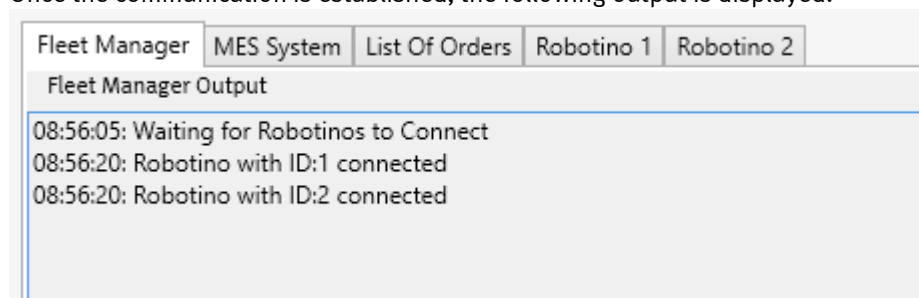

Figure 3: Output after communication established

10.1.2 MES System Information

Contains all information critical for connection between Fleet Manager and MES System.

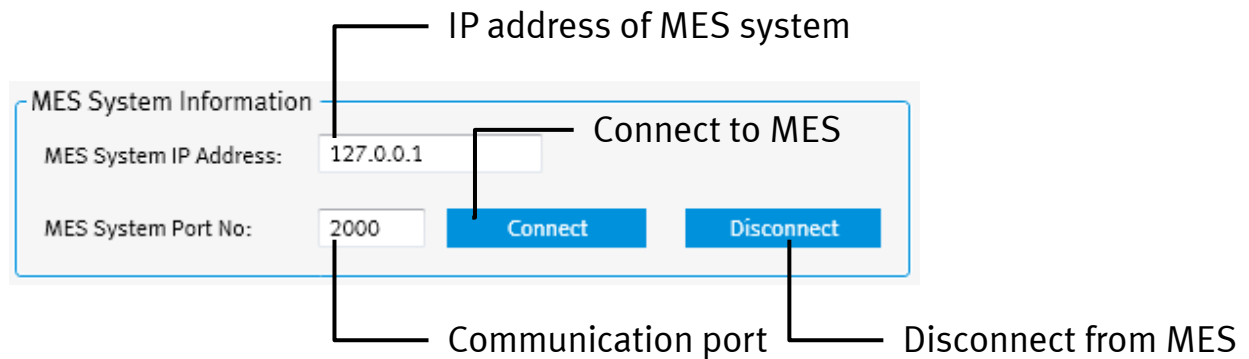

Figure 4: MES System configuration information

Steps to establish connection between Fleet Manager and MES System.

1. Switch all the Robotino to manual mode.
2. If already connected, disconnect from MES.
3. Enter the IP address of the MES System.
4. Enter the Port No. used for communication.
5. Click on the “Connect” button.

Once the communication is established, the following output is displayed in the output tab.

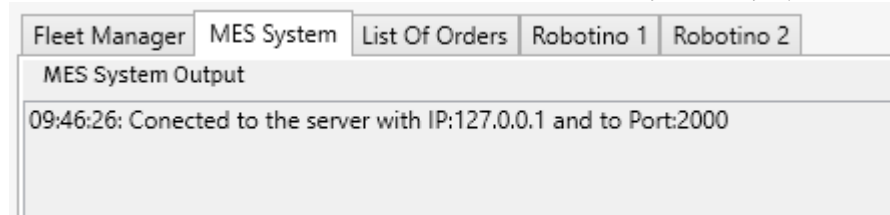

Figure 5: Output after getting connected to MES System

Once connected to the MES System, the Fleet Manager can receive the orders from MES System and command the Robotino.

10.1.3 Fleet Command Center

The Command Center gives an overview of the Robotino status, which are a part of the fleet. It can also be used, to control individual Robotino manually.

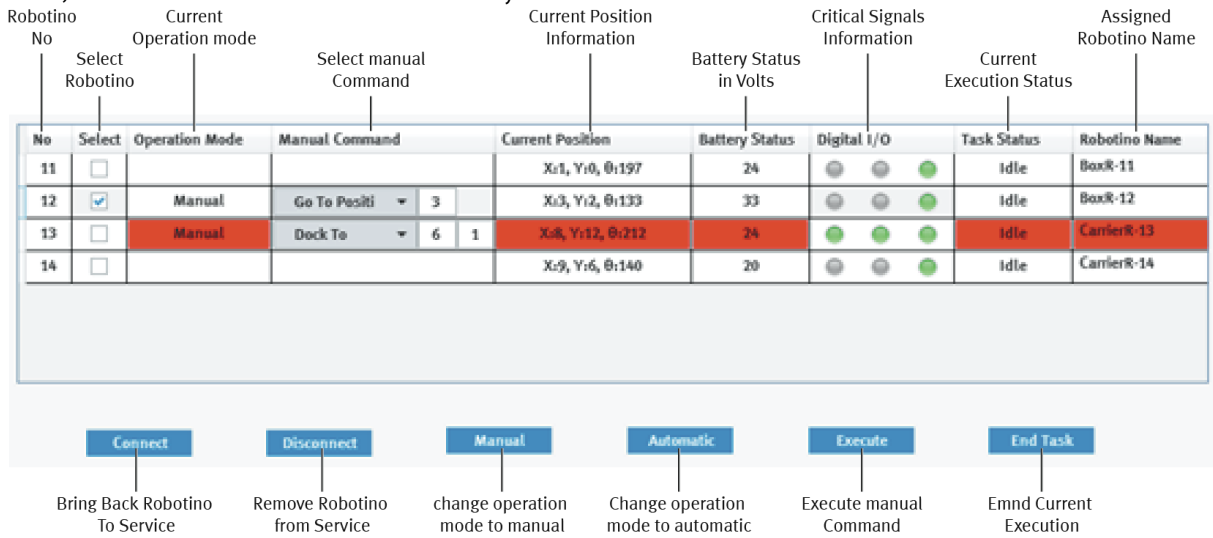

Figure 6: Fleet Command Center

The table contains the following.

1. Robotino No (Robotino ID entered in Web-interface)
2. Selection box to dispatch commands to individual Robotino
3. Operation Mode (Indicates the mode in which the Robotino is currently operated)
4. Manual Command (Appears when “Operation Mode” is manual)
5. Current Position (The current position of the Robotino in X, Y and the heading angle)
6. Present status of the Robotino battery in Volts.
7. Important digital signal information with the sequence (Laser warning, Laser safety, Box present)
8. The status of the Robotino.
9. The name of the Robotino entered in the settings.

Note 1:

The commands to Robotino’s are sent by clicking on the button below the table.

Note 2:

Any button click can only be executed when the selection box in the “**Select**” column is checked.

Note3:

The Robotino "No" with an orange background indicates that the Robotino is currently in the "Reserve AGV" position.

Note 4:

The red background color of the cell indicates that the emergency stop of that Robotino is active.

The functionalities of individual buttons are explained below.

Connect

- If the current **“Operation Mode”** is **“Out of service”** bring back the Robotino to service.
- The corresponding output is displayed in the **“Fleet Manager”** output tab.

Disconnect

- If the Robotino is in operation and is required to remove it from service.
- The corresponding output is displayed in the **“Fleet Manager”** output tab.

Manual

- Sets **“Operation Mode”** to Manual, in this mode the orders from MES System cannot be processed.
- Only sets to manual mode no command is sent to Robotino

Automatic

- Sets **“Operation Mode”** to Automatic, in this mode, the logistic orders will be read from the MES system and processed.
- The transmitted order information is displayed in the corresponding **“Robotino”** output tab.
- When any error occurs in automatic mode a window pops up along with an **ALARM** sound and waits for the user to acknowledge the error.

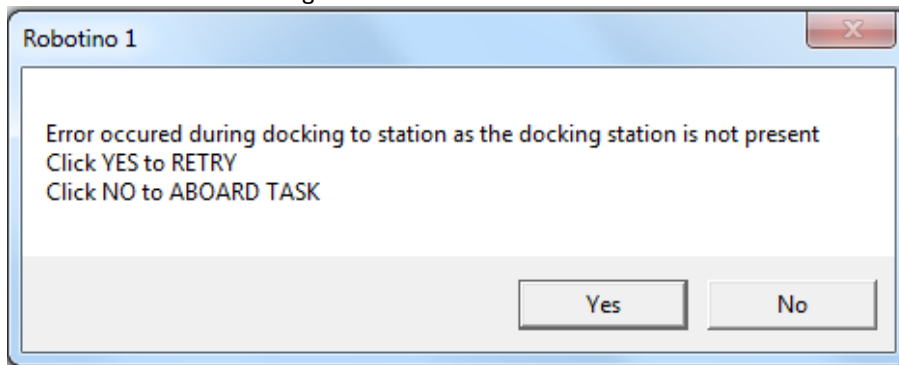

Figure 7: Error message from the Robotino

- Click **“Yes”** if the reason for error has been resolved or **“No”** to terminate the task.

Note 1:

Until the user acknowledge the “Error Message” Robotino will not continue.

Note 2:

If an order exists in MES System and the fleet manager is not processing them, please check the **connection between MES System and Fleet Manager** and make sure the **MES ID and Position ID are entered correctly in the “Position Settings”**.

Execute

When the “operation Mode” is set to manual, the “Manual Command” column in the table gets populated with options for all possible manual commands.

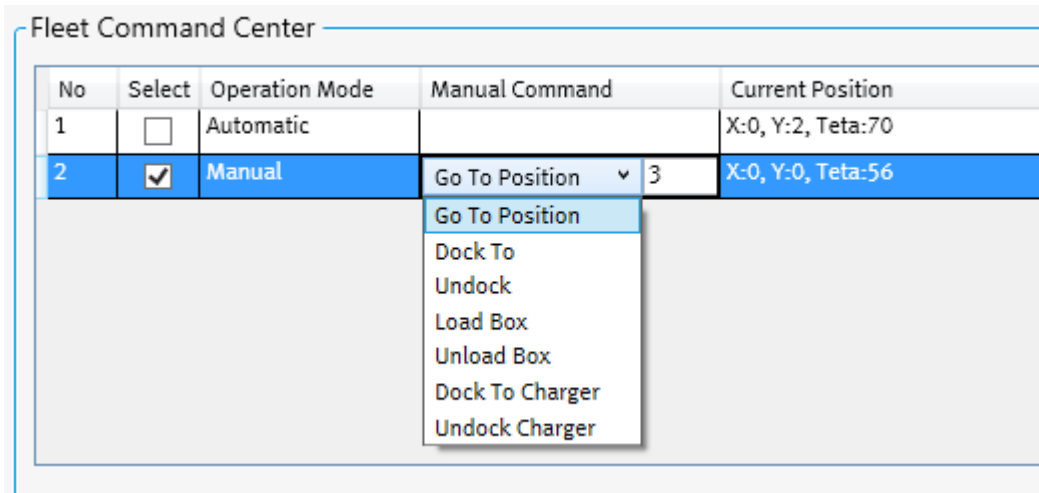
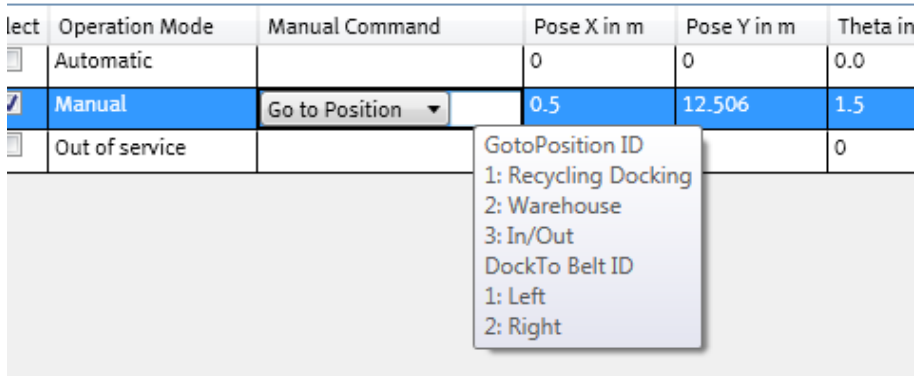

Figure 8: Manual command options

Steps for executing a manual command

1. Select a manual command from the available option, a help pops up while entering the number.



Connect **Manual** **Automatic** **Execute**

Figure 9: Pop-up help for entering a valid ID

2. Once a valid ID is entered click Execute.

Note:

A new command can only be sent to Robotino when the previous task is completed.

End Task

- End the current task being executed, irrespective of its “Operation Mode”.

10.1.4 Out tabs

The outputs corresponding to different elements of the Fleet Manager are all sorted accordingly to output tabs. The different output tabs are:

1. Fleet Manager (All relating to Fleet Manager and Robotino connection)
2. MES System (All related to MES System and Fleet Manager)
3. List of orders (Overview of open/on-going logistic orders)
4. Robotino “n”

In the list of orders tab, user can monitor the open and on-going logistics tasks. The details of the locked stations by individual Robotino can also be see on this tab.

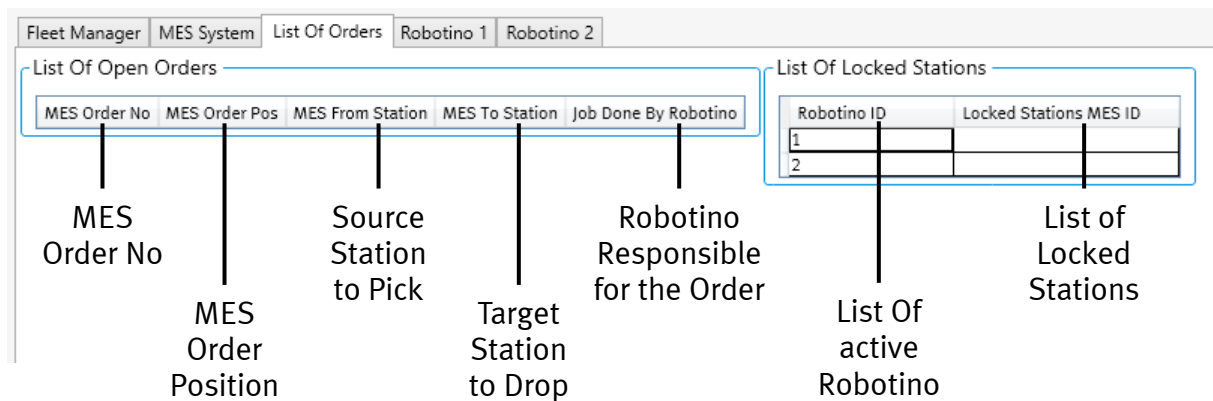

Figure 10: List of Orders tab

The Robotino output tab has two sections, the upper section displays the commands sent from Fleet Manger to Robotino and the lower section displays the status updated from the Robotino to Fleet Manager.

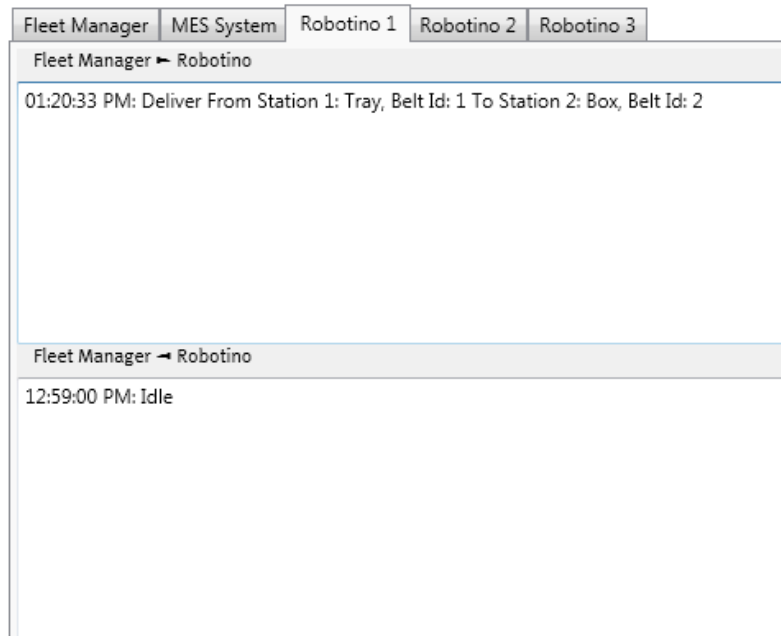

Figure 11: Robotino command & state output tab

10.2 Preferences

The basic layout of the settings tab is shown in the figure below.

The screenshot displays the 'Switch User' and 'Start-Up Settings' sections of the Festo Fleet Manager software configuration interface.

Switch User: This section includes a dropdown menu for 'Login As:' currently set to 'Operator', a 'Password:' input field, and a blue 'Log In' button.

Start-Up Settings: This section includes a dropdown menu for 'Login As:' currently set to 'Administrator', a 'Password:' input field with masked characters, and several configuration options:

- 'Auto start Fleet Manger Server on start-up' with a checked checkbox.
- 'If 100 no.of jobs done then charge for minimum 1 minutes' with input fields for '100' and '1'.
- 'If voltage is less than 20 volts then charge for minimum 1 minutes' with input fields for '20' and '1'.
- 'Enable logging function' with a checked checkbox.
- 'Fleet Manager used with CIROS' with an unchecked checkbox.

At the bottom of the 'Start-Up Settings' section are 'Apply' and 'Candle' buttons. Below the entire settings area is a 'Restore Factory Settings' button.

Figure 12: Fleet manager software configuration

Here in the settings tab the fleet manger software is configured. The user at any point during the operation has the freedom to switch between “Operator” and “Administrator”.

Note 1:

There is no password to login as the “operator”. When logged in as an operator the user can only connect, disconnect and command the Robotino. user has no privilege of changing any of the settings.

Note 2:

The **password** to login as “Administrator” is “SolutionCenter”. The Admin has the complete privilege of changing any of the settings as per the requirements.

Note 3:

In the “Start-Up Settings”, the user can predefine the settings which will be effective on every start-up of the fleet manager software.

Note 4:

The “Restore Factory Settings” button will reset all the settings to the factory default settings. To reset to factory default the user must be logged in as Administrator.

10.3 Position Settings

In the position settings a suitable relation between the taught position ID (Factory-4 software) and the MES Resource ID is made.

Position Info

No. of Positions taught:

Position List

Position ID	MES ID	Buffer No	Position Tag	Pose Type	Default station	Reserve AGV	Package Type
<input type="text" value="1"/>	<input type="text" value="1"/>	<input type="text" value="0"/>	<input type="text" value="CP-F-RASS-1"/>	<input type="text" value="CP System"/>	<input type="radio"/>	<input type="checkbox"/>	<input type="text" value="Box"/>
<input type="text" value="2"/>	<input type="text" value="2"/>	<input type="text" value="0"/>	<input type="text" value="CP-F-RASS-2"/>	<input type="text" value="CP System"/>	<input type="radio"/>	<input checked="" type="checkbox"/>	<input type="text" value="Box"/>
<input type="text" value="3"/>	<input type="text" value="3"/>	<input type="text" value="0"/>	<input type="text" value="CP-F-RASS-3"/>	<input type="text" value="CP System"/>	<input type="radio"/>	<input type="checkbox"/>	<input type="text" value="Carrier"/>
<input type="text" value="4"/>	<input type="text" value="4"/>	<input type="text" value="0"/>	<input type="text" value="CP-F-BUF-ROB"/>	<input type="text" value="Manual work"/>	<input type="radio"/>	<input type="checkbox"/>	<input type="text" value="Carrier"/>
<input type="text" value="990"/>	<input type="text" value="990"/>	<input type="text" value="0"/>	<input type="text" value="Charging"/>	<input type="text" value="Charging"/>	<input type="radio"/>	<input type="checkbox"/>	<input type="text" value="Box"/>
<input type="text" value="991"/>	<input type="text" value="991"/>	<input type="text" value="0"/>	<input type="text" value="Parking"/>	<input type="text" value="Parking"/>	<input type="radio"/>	<input type="checkbox"/>	<input type="text" value="Box"/>

Figure 13: Position List Configuration

Steps to configure positions:

1. We begin by entering the No. of Positions taught on the Robotino.
2. Click on Submit.
3. Enter the values into the empty fields.
4. Click “Apply” to keep the changes or “cancel” to undo changes.
5. When an undefined box is given out from any of the station, it always goes to the default station.

Note 1:

To make any changes the user must be logged in as “Administrator”

Note 2:

The “MES ID” must be entered correctly corresponding to the “Transport Stations” configured in the “MES Software”. If a wrong value is entered the Robotino will be unable to execute the orders.

Note 3:

The “Buffer No” is configured if a single MES resource has multiple positions to dock.

Note 4:

If the check box “Reserve AGV” is checked, Robotino waits at this location after completing its task. Robotino will continue only when a task has a source starting at that point.

Note 5:

If a parking pose is defined and not occupied by any other Robotino, the Robotino after completing the delivery task drives to the parking position in the event it blocks other Robotino from completing the task.

Note 6:

If a charging pose is defined and not occupied by any other Robotino, the Robotino will drive to the charging station after the conditions for charging operations are satisfied. (See settings window)

10.4 Robotino Settings

In the exception settings, we define the Robotino list and the forbidden tasks for the individual Robotino. The exception settings tab is shown in the figure below.

The interface is divided into three sections:

- List of Robotino's:** A table with columns for Robotino ID, MES ID, MES Tag, and Robotino Type. It contains two entries: (1, 15, LOG-M-C1, Carrier Transporter) and (2, 16, LOG-M-C2, Carrier Transporter). Below the table are 'Apply' and 'Cancel' buttons.
- Exception:** A form with dropdown menus for 'Robotino ID' (2:LOG-M-C2), 'From Station' (2:CP-L-Branch-2), and 'To Station' (5:CP-L-RobCell_2-In). There is an unchecked checkbox for 'Both Direction' and an 'Add Exception' button.
- Exception List:** A table showing the configured exceptions. The second entry is highlighted in yellow.

No	Robotino ID	From Station	To Station
1	1:LOG-M-C1	1:CP-L-Branch-1	2:CP-L-Branch-2
2	2:LOG-M-C2	2:CP-L-Branch-2	5:CP-L-RobCell_2-In

Figure 14: Exception Configuration

Steps to configure an exception:

1. We begin by entering the Robotino ID and the corresponding MES ID
2. Click on Apply.
3. Select the required Robotino and the forbidden path(from station and to station)
4. If you would like to forbid both the direction select the check box
5. Click on the “Add Exception” button. You can see the list of exception and delete it when not required.

Note 1:

To make any changes the user must be logged in as “Administrator”

Note 2:

Make sure the MES ID is same as in the MES software.

11 Resetting network settings

In case you need to reset the network settings of Robotino to the state of delivery, perform the following instructions.

1. Start

Start Robotino by pressing the main power switch on the control unit for about 3 seconds.



The start up takes up to 30 seconds.

2. Resetting network settings

Press the reset key at the bottom of the control unit of Robotino for about 3 seconds.



All network settings will be reset. The network name (SSID) of the access point as well as the IP address of Robotino correspond to the specification stated on the nameplates of your Robotino. Now perform the steps in the initial start up to test the network settings.

12 Assembly and Connectors

12.1 Installing the optical sensors

The optical sensors need to be mounted to the mounting plates in the loading bay of Robotino and has to be connected to the I/O-Interface.

Required tools:

- Allen keys 2.5 mm and 3 mm
- Open-end wrench 10 mm
- Phillips screwdriver 3 mm

1. Pre-assembling the sensors

All of the components for the optical sensors must be pre-assembled before they are mounted to Robotino and connected. For each sensor you need one fibre-optic unit, one fibre-optic cable and one retainer for the fibre-optic cable.

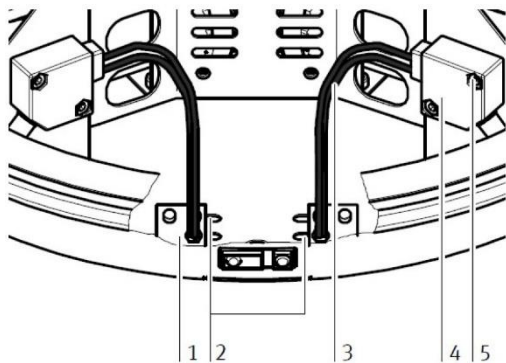

Fibre-optic mounting bracket (1), Mounting slots (2), Fibre-optic cables (3), Fibre-optic unit (4), Mounting screws and holes (5)

First of all, cut the two fibre-optic cables to the required length. It is absolutely essential to use a fibre-optic cutting device to this end, in order to assure that the fibre-optic cables are not destroyed, and to ensure error-free functioning. Screw the fibre-optic head into the mounting bracket until it protrudes from the other side by approximately 2 mm. Secure it with the included nut. When the mounting brackets are attached to the chassis during a later assembly step, it must be assured that the sensors are located at the inside ends of the slots. Otherwise, the distance between the sensors cannot be changed.

Insert the free end of the fibre-optic cable into the black retainer in the fibre-optic unit. Push it all the way in until resistance is plainly perceived. Tighten the retainer with the Phillips head screw.

2. Mounting the sensors on the chassis

Now mount the sensors on the chassis of Robotino. First of all, secure the fibre-optic mounting bracket (1) to the bottom of the chassis by inserting two screws into the slot (2) from underneath. How far apart the fibre-optic cables (3) need to be mounted depends upon the width of the object to be detected. Screw the fibre-optic mounting bracket to the chassis at the location shown in the photo. The mounting bracket is secured from underneath with the included screws (3 mm hexagon socket head screws). Secure both mounting brackets. Now mount the fibre-optic unit (4) to the mounting plate in the Robotino. Secure it to the threaded holes provided to this end with the included screws (5).

3. Connecting the sensors

Connect the optical sensors to the power supply and to the digital inputs of the I/O interface.



Verify the following circuit specification using the data sheet of the optical sensors.

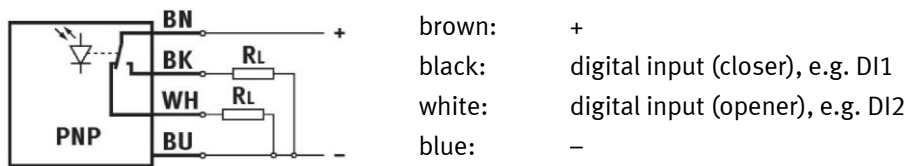

4. Adjusting the sensors

Use the enclosed small screwdriver, turn the adjusting screw until the operating status display (LED) switches on to adjust the optical sensors. Check if the respective sensor switches off at the corresponding position on a dark background.

12.2 Installing the inductive sensor

The inductive sensor is mounted in one of the three predetermined positions in the floor plate of Robotino and has to be connected to the I/O-Interface.

Required tools:

- Open-end wrench 17 mm

1. Mounting the sensors

Select either one of the two circular openings in the bottom panel of the loading bay of Robotino or the opening in the centre of the bottom plate to mount the inductive sensor. Turn the upper lock nut onto the sensor thread, slide the sensor with the plug side up into the opening provided, keep it in the desired position and fix the sensor with the lower lock nut.

2. Connecting the sensors

Connect the inductive sensor to the power supply and to one analogue input of the I/O interface.



Verify the following circuit specification using the data sheet of the optical sensors.

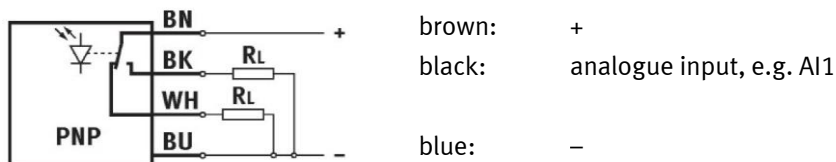

13 Extensions Robotino

13.1 Extension with Sick Laserscanner

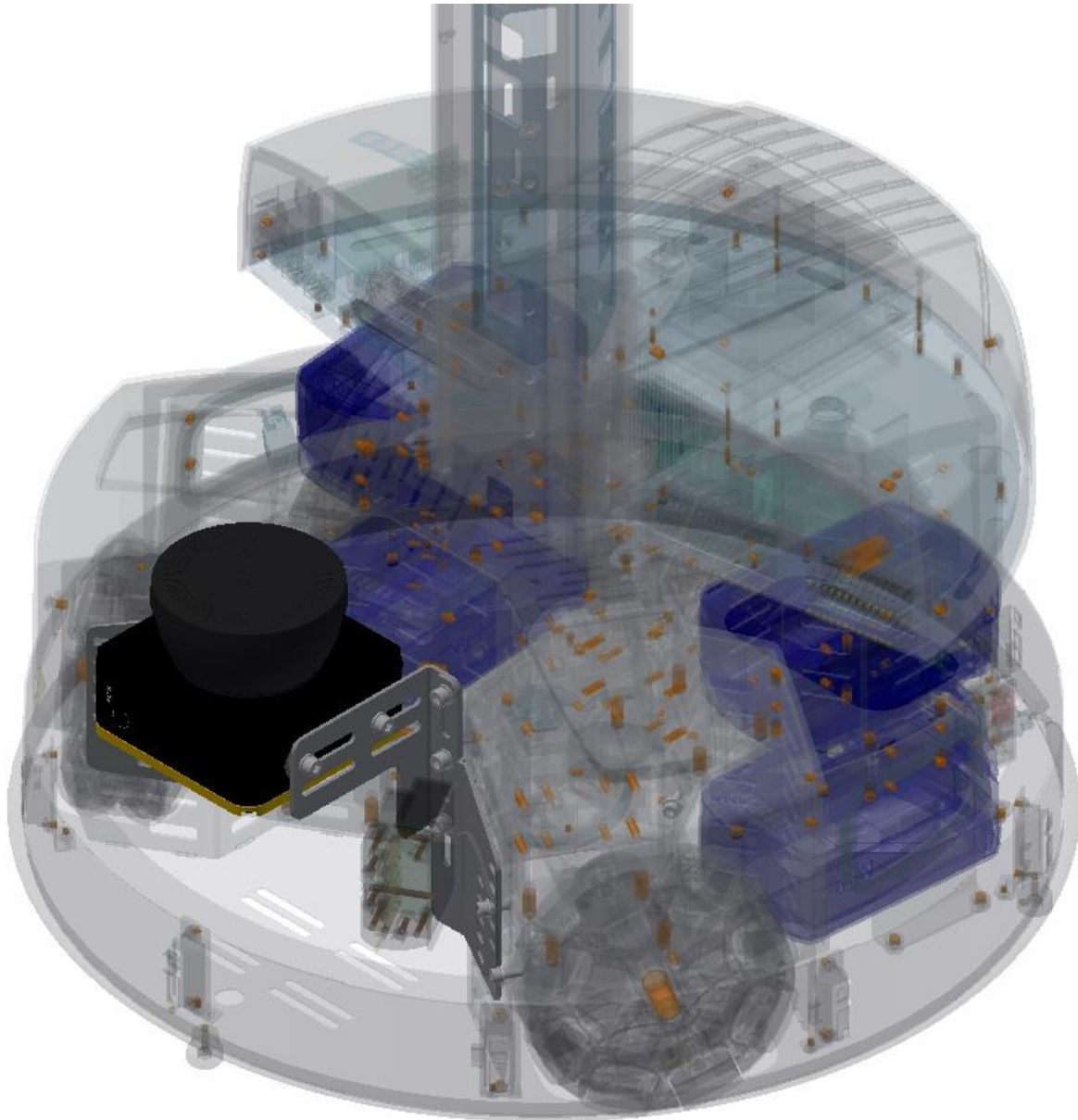

Illustration similar

The task of the laser scanner is to secure the travel path of the robot. The scanner checks the surroundings in the direction of travel while driving the Robotino. If obstacles appear in the travel path, the Robotino can bypass them.

13.2 Extension with workpiece box reception

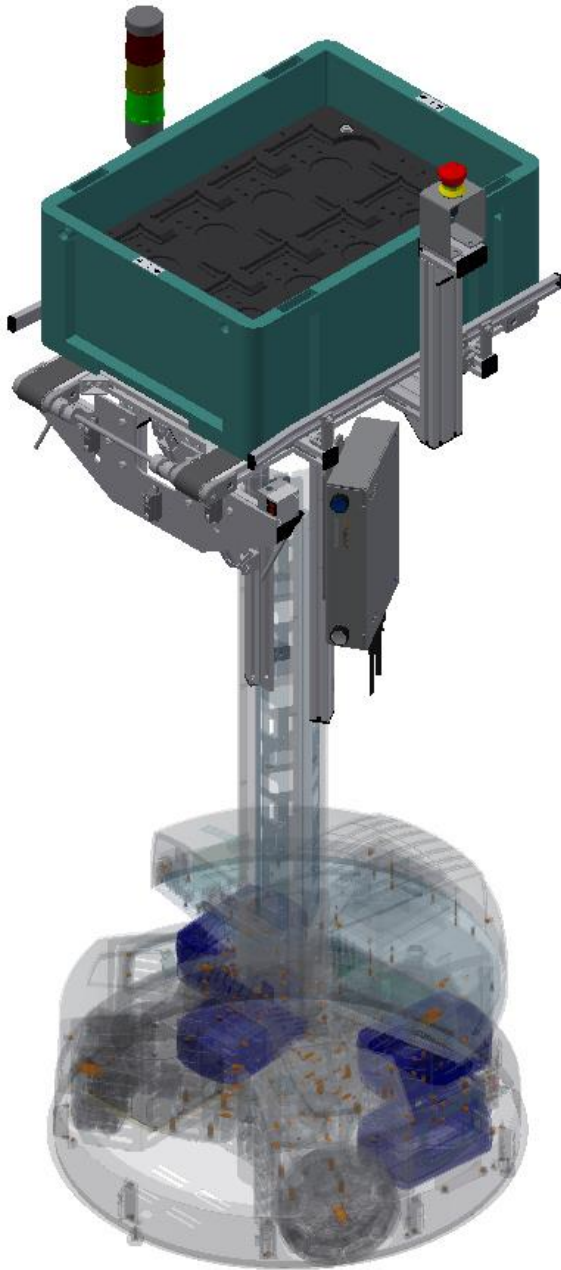

Illustration similar

The task of the box reception is to pick up a box at one station and deliver it to any other station. The belts move the box into the pick-up station.

Note

When the "tower" is set up, there is a risk of the mounted belt system being pulled in. Make sure that there is no interference.

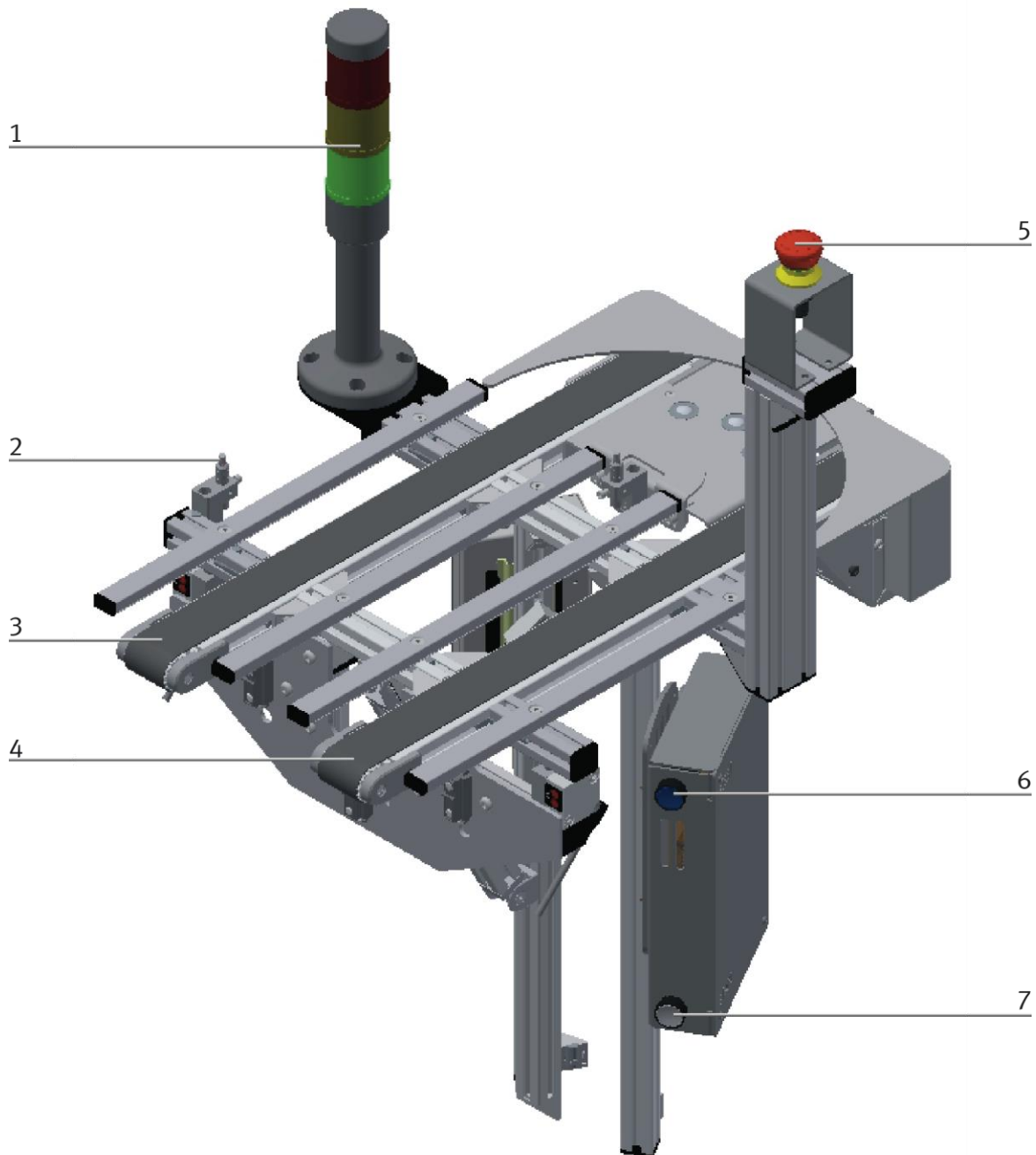

Illustration similar

Position	Description
1	Signal lamp / P1 = red / P2 = yellow / P3 = green
2	Workpiece request workpiece carrier available (BG1)
3	Conveyor output
4	Conveyor input
5	Emergency Stop switch (SF1)
6	Reset switch / lamp (SF3)
7	Start switch / lamp (SF2)

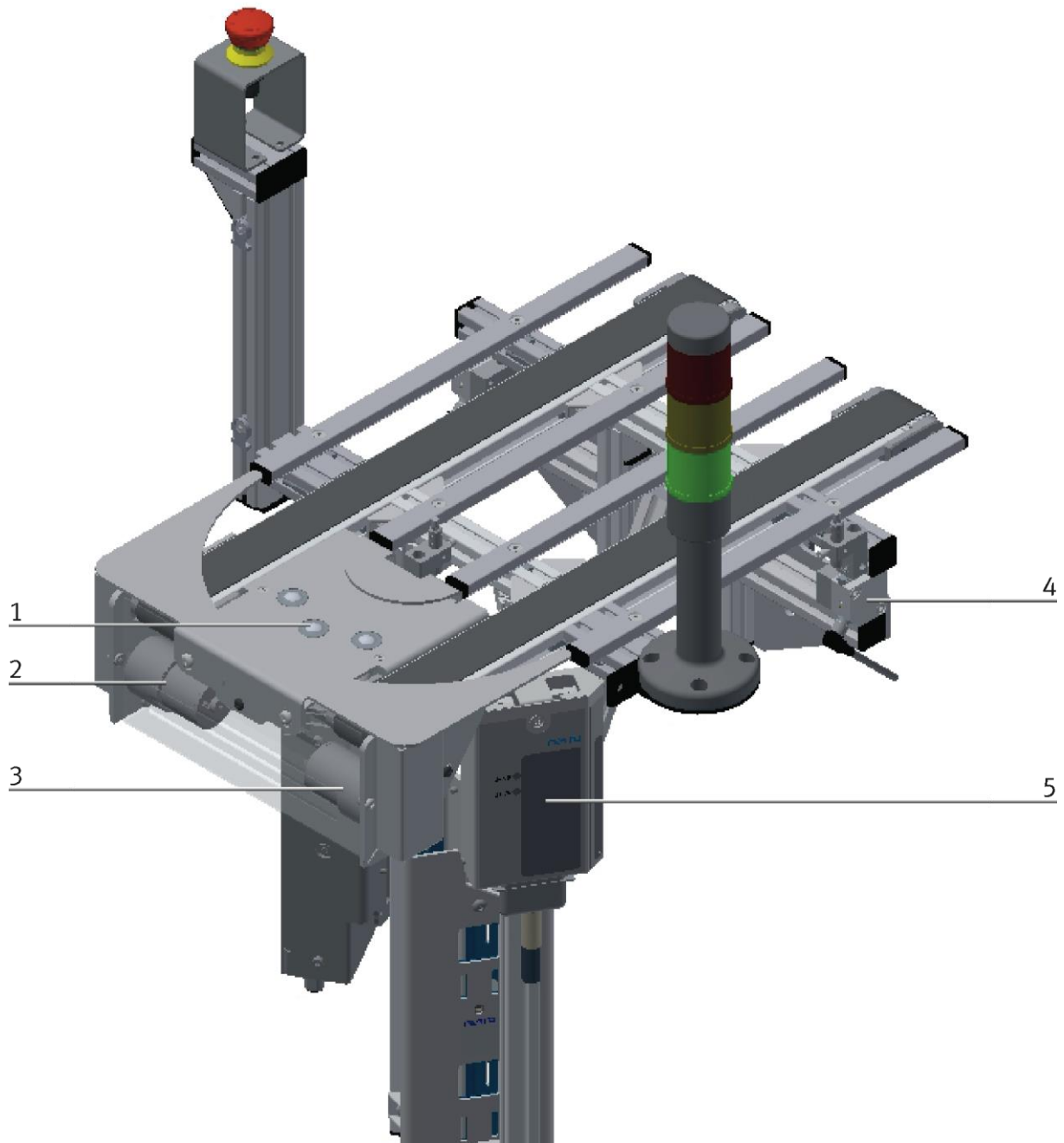

Illustration similar

Position	Description
1	Workpiece redirection
2	Motor input
3	Motor output
4	Sensors for positioning at transfer stations
5	I/O Box

13.4 Charging kit

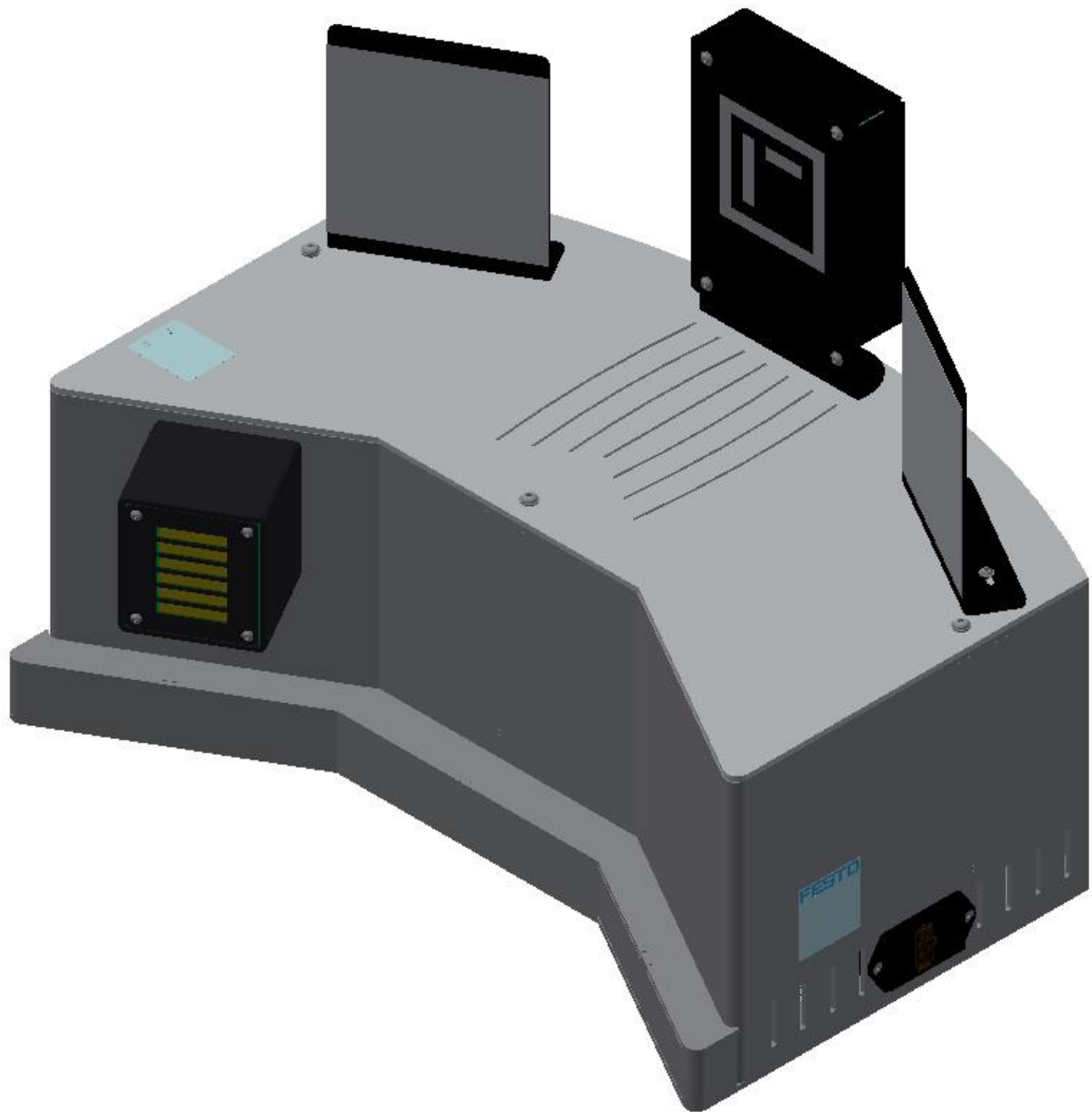

Illustration similar

The Robotino has an automatic charging station which it approaches automatically depending on the settings in the Fleet Manager software.

For the connection between the Robotino and the charging station, it is necessary to install a contact plug (1) on the Robotino.

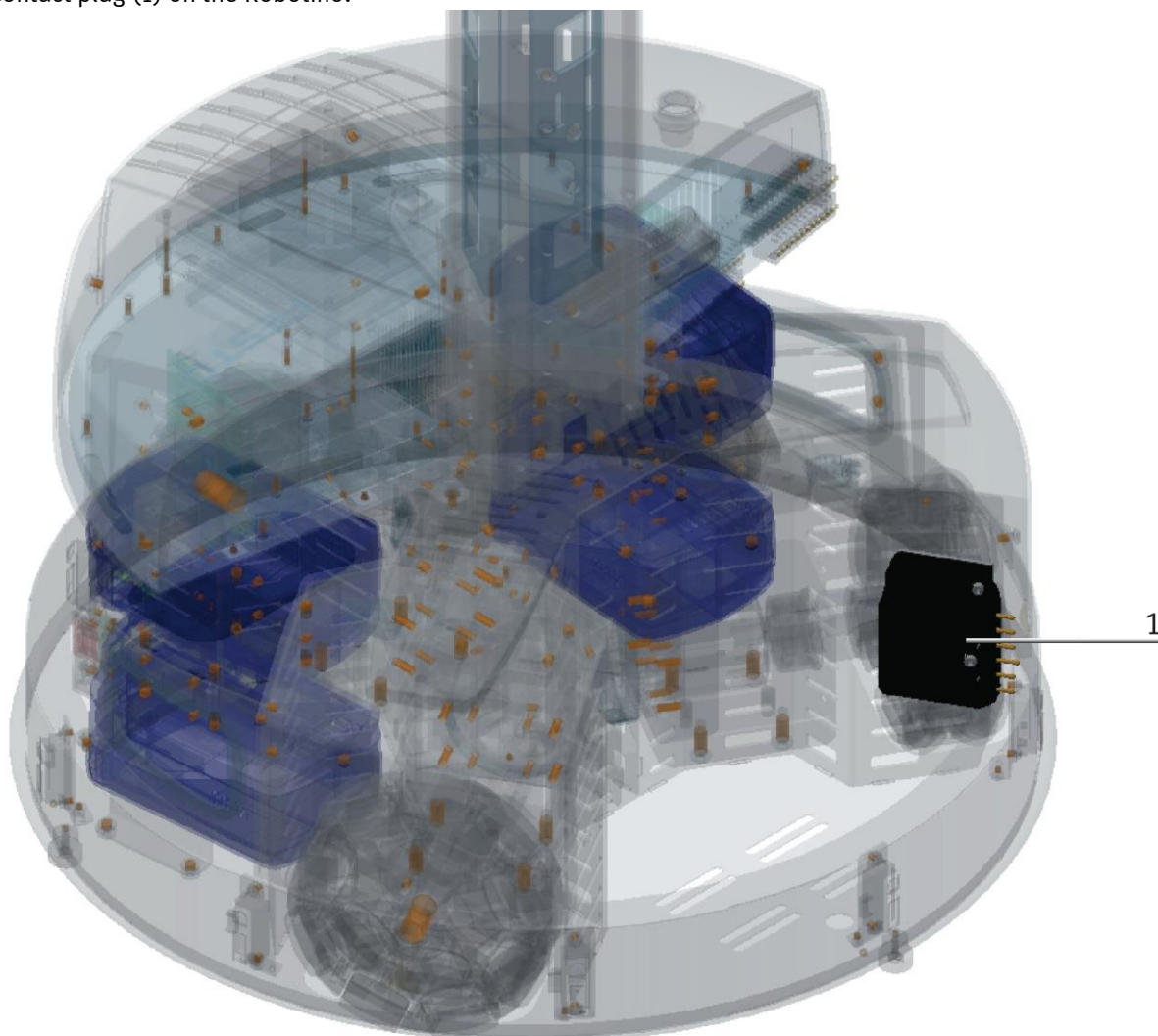

Illustration similar

This accessory pack increases the range of the Robotino. The station can be approached in three different and combinable ways: Via optical sensors, by means of image processing of the 2D marker, or using a laser scanner. The different approach options can be used manually or in automatic mode. The charging station is directly compatible with the charging points used by Robotino Factory.

The charging station is intended for use with the Robotino 4 mobile learning system. The package creates the technical prerequisite for docking Robotino 4 without further handling and sequentially charging the battery packs. During the charging process, Robotino 4 remains in operation and is operated with mains voltage to avoid battery drainage.

Technical data

Operating voltage according to selected version 120V/230V

Power consumption: max. 240 W

Dimensions: 535 mm x 212 mm x 152 mm

Weight: approx. 14 kg

Protection class IP20

Components

Charging station and contact for Robotino 120 V (Order no.: 8134658)

Charging station and contact for Robotino 230 V (Order no.:8134659)

Included components:

1x charging contact (Order no.:8131075)

Connection of charging contact

The charging contact has 4 individual wires and a 3-pole cable, these are fed through the sheet metal to the rear and connected as shown in the following table.

Charging contact	Clamp Robotino
Single wire red	XD3: 24V out
Single wire blue	XD3: GND
Single wire black	XD4: +
Single wire blue	XD4: -
3 pol cable white	XD4: SDA
3 pol cable green	XD4: SCL
3 pol cable brown	XD4: VCC

14 Service and cleaning

The components and systems from Festo Didactic are largely maintenance-free.

At regular intervals you should have checked:

- the lenses of the optical sensors, fibre optics and reflectors
- the active surface of the proximity switch
- the entire station

can be cleaned with a soft, lint-free cloth or brush.

	<p style="text-align: right;"><i>NOTE</i></p> <p>Do not use aggressive or abrasive cleaners.</p>
---	---

Protective covers must not be cleaned with alcoholic cleaning agents, there is a risk of embrittlement.

There is a special maintenance manual for CP Systems, see this manual for further information.

15 Further information and updating

Further information and updates on the technical documentation of Festo Didactic components and systems can be found on the Internet at:

www.ip.festo-didactic.com



16 Disposal

	<p style="text-align: center;"><i>NOTE</i></p> <p>Electronic waste contains recyclable materials and must not be disposed of with the domestic waste. Bring electronic waste to a designated municipal collection point.</p>
---	---

Festo Didactic SE

Rechbergstraße 3
73770 Denkendorf
Germany



+49 711 3467-0



+49 711 34754-88500



www.festo-didactic.com



did@festo.com