



# &EAB

# Inhaltsverzeichnis Table of contents

Date	12.01.2021	Festo Didactic SE
Ed. by.	Schuhmacher	Rechbergstraße 3
Creat.	Schuhmacher	D-73770 Denkendorf
Drw.Nr.	N:	F:

<b>FESTO</b>	Übersicht
	overview

S-Nr.	8088783
PSP / DPJ	VN

= E	Oven	Page 2
+		of 14



Diese Zeichnung ist Eigentum der Festo Didactic SE. This drawing is the property of Festo Didactic SE.

# &EPC

# Stückliste

# Bill of materials

<&EAB/3

5>>

Date	12.01.2021	Festo Didactic SE
Ed. by.	Schuhmacher	Rechbergstraße 3
Creat.	Schuhmacher	D-73770 Denkendorf
Drw.Nr.	N:	F:



Übersicht  
overview

S-Nr.	8088783
PSP / DPJ	VN

= E	Oven	Page 4
+		of 14

\\vesto.net\dfs01\INT\Data\EPLAN\DATA\_xx\DE\Projects\Didactic\Products\26 CP-AM\01.02 CP-AM-OVEN.elk





Diese Zeichnung ist Eigentum der Festo Didactic SE. This drawing is the property of Festo Didactic SE.

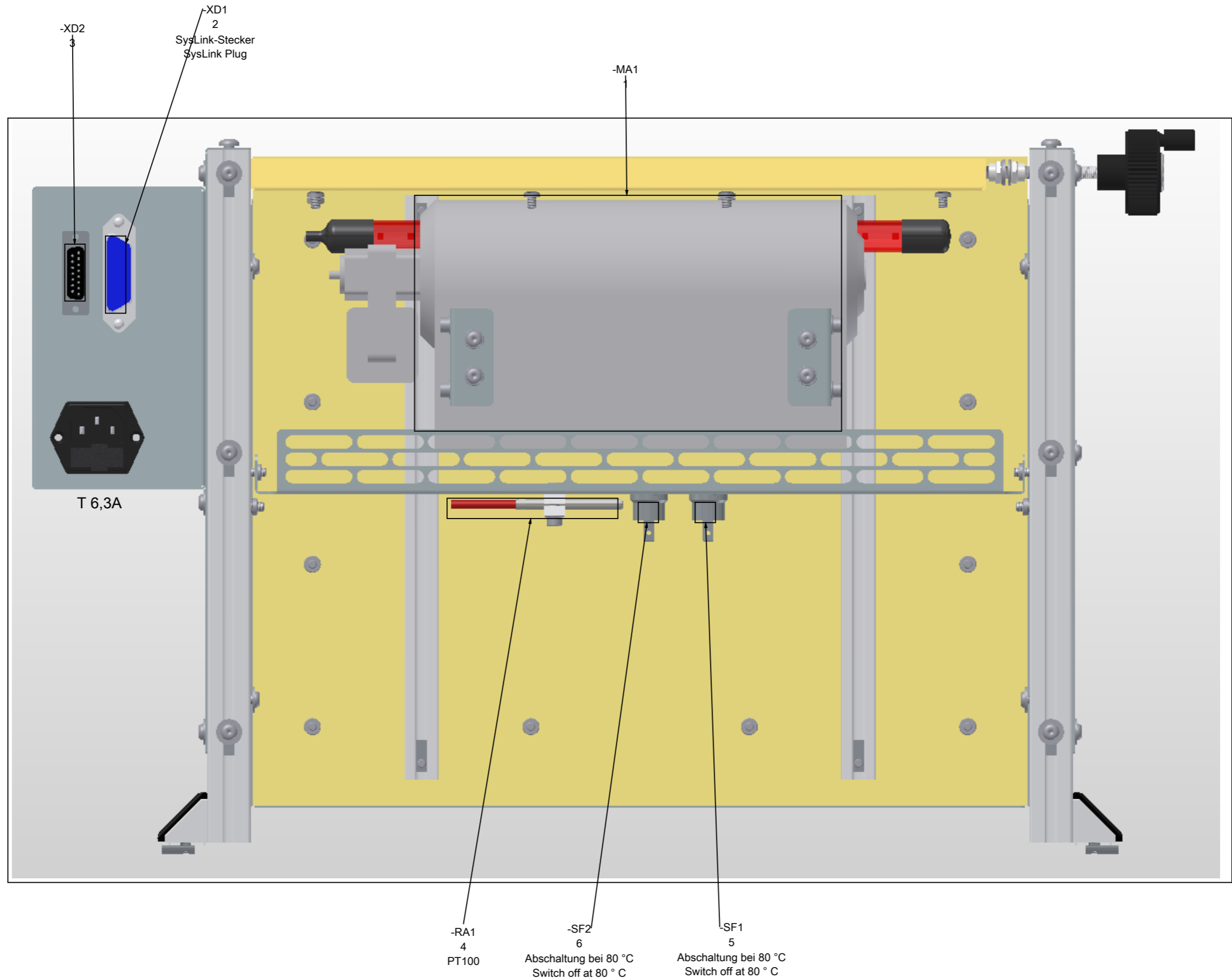

<<EPC/6

8>>

Date	12.01.2021	Festo Didactic SE
Ed. by.	Schuhmacher	Rechbergstraße 3
Creat.	Schuhmacher	D-73770 Denkendorf
Drw.Nr.	N:	F:

**Aufbauplan**  
**assembly**

S-Nr.	<b>8088783</b>
PSP / DPJ	VN

= E	Oven	Page 7
+ EB	OVEN	of 14

Diese Zeichnung ist Eigentum der Festo Didactic SE. This drawing is the property of Festo Didactic SE.

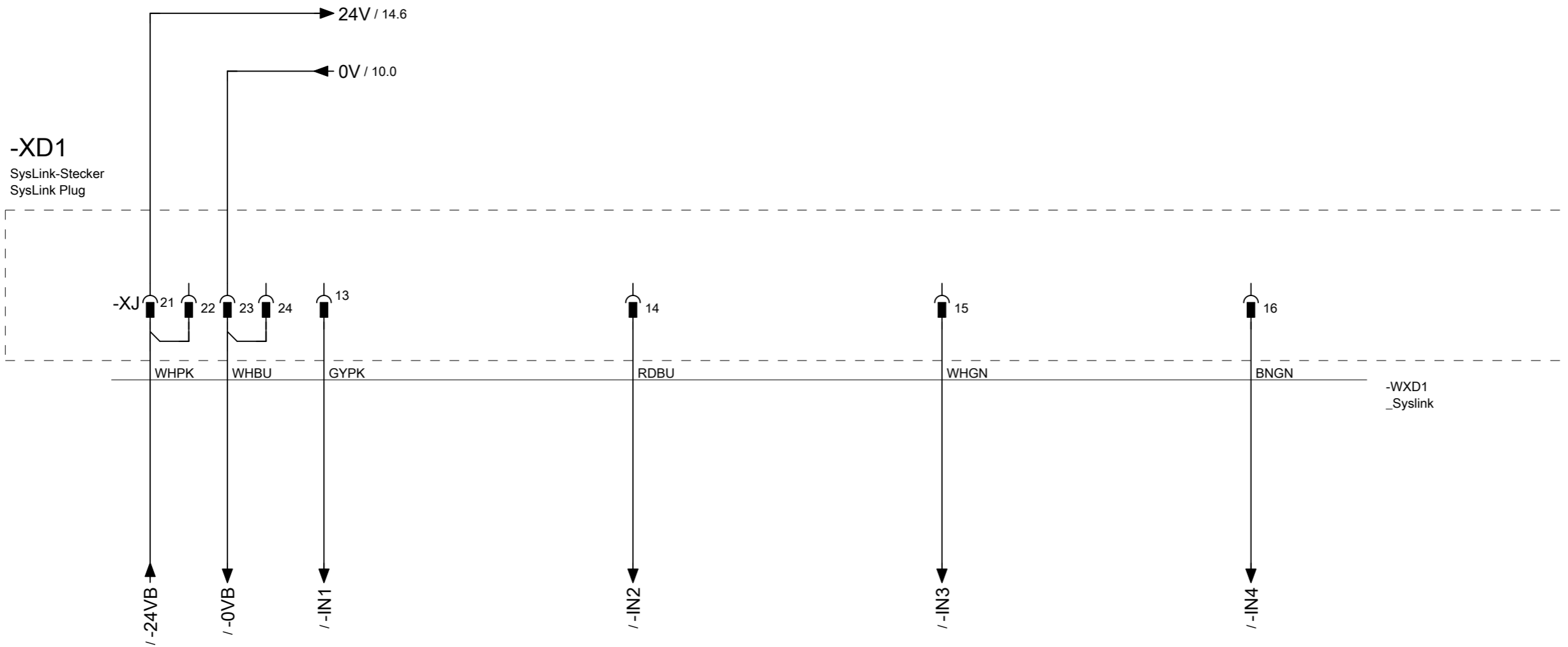

Reserve  
Reserve

Reserve  
Reserve

Reserve  
Reserve

Reserve  
Reserve

<7

9>>

Date	12.01.2021	Festo Didactic SE	
Ed. by.	Schuhmacher	Rechbergstraße 3	
Creat.	Schuhmacher	D-73770 Denkendorf	
Drw.Nr.	N:	F:	EPL0VZFG7M \\vesto.net\dfs01\INT\Data\EPLAN\DATA_xx\IDE\Projects\Didactic\Products\26 CP-AM\1.02 CP-AM-OVEN.elk



Eingänge  
inputs

S-Nr.	8088783
PSP / DPJ	VN

= E	Oven	Page 8
+ EB	OVEN	of 14



Diese Zeichnung ist Eigentum der Festo Didactic SE. This drawing is the property of Festo Didactic SE.

**-XD1**  
SysLink-Stecker  
SysLink Plug

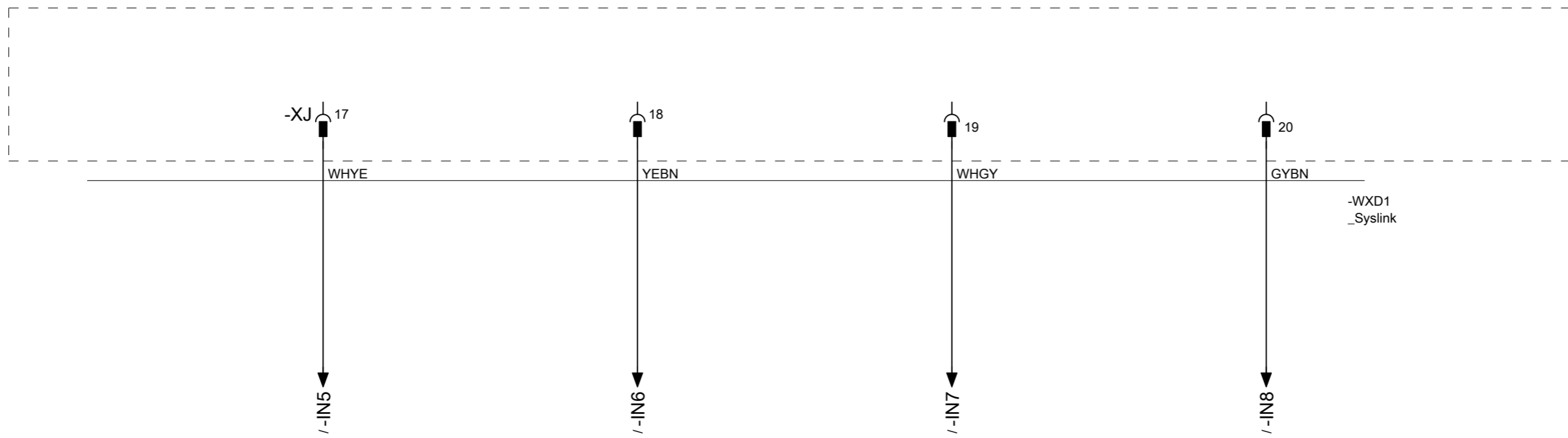

Reserve  
Reserve

Reserve  
Reserve

Reserve  
Reserve

Reserve  
Reserve

-WXD1  
\_Syslink

Date	12.01.2021	Festo Didactic SE	
Ed. by.	Schuhmacher	Rechbergstraße 3	
Creat.	Schuhmacher	D-73770 Denkendorf	
Drw.Nr.	N:	F:	EPL0VZFG7M \\vesto.net\dfs01\INT\Data\EPLAN\DATA_xx\IDE\Projects\Didactic\Products\26 CP2 AM 01.02 CP-AM-OVEN.elk



Eingänge  
inputs

S-Nr.	8088783
PSP / DPJ	VN

= E	Oven
+ EB	OVEN

Diese Zeichnung ist Eigentum der Festo Didactic SE. This drawing is the property of Festo Didactic SE.

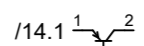
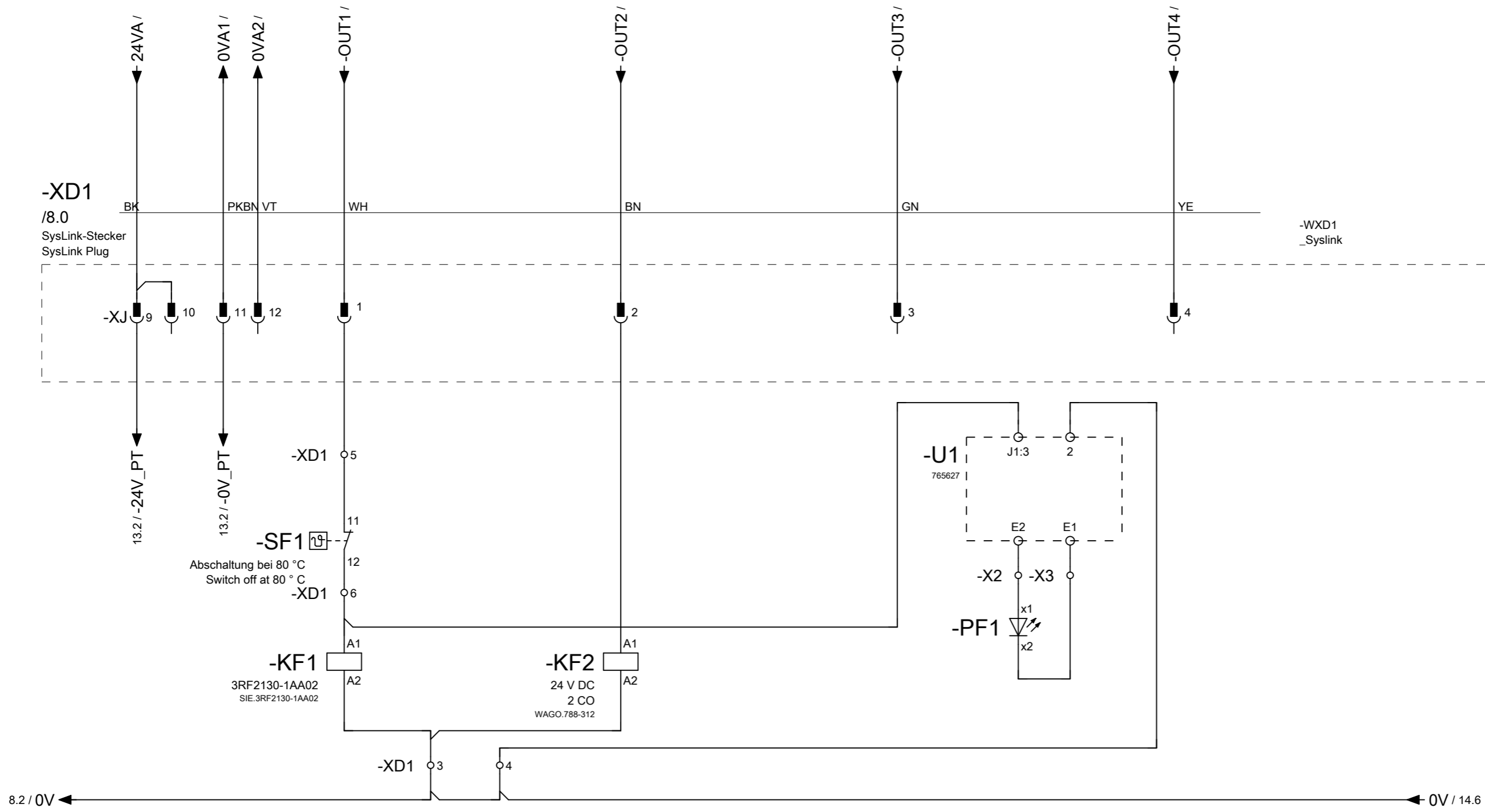

Heizung  
einschalten  
heater  
turn on

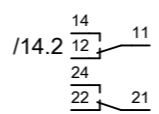

heizleistung  
heating capacity

Reserve  
Reserve

Reserve  
Reserve

Diese Zeichnung ist Eigentum der Festo Didactic SE

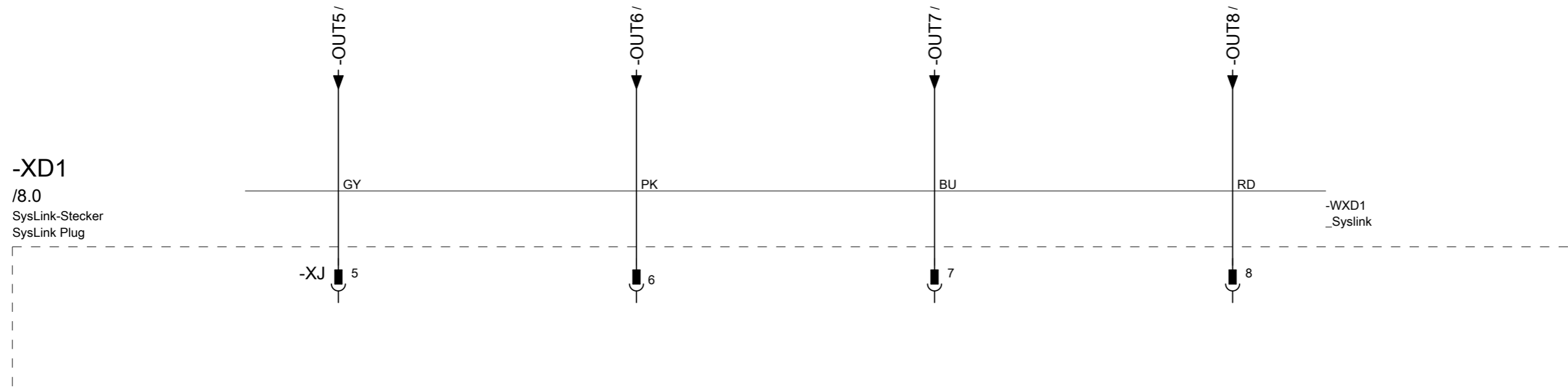

Reserve  
Reserve

Reserve  
Reserve

Reserve  
Reserve

Reserve  
Reserve

Date	12.01.2021	Festo Didactic SE
Ed. by.	Schuhmacher	Rechbergstraße 3
Creat.	Schuhmacher	D-73770 Denkendorf
Drw.Nr.	N:	F:



Ausgänge  
outputs

S-Nr.	8088783
PSP / DPJ	VN

= E	Oven	Page 11
+ EB	OVEN	of 14

Diese Zeichnung ist Eigentum der Festo Didactic SE. This drawing is the property of Festo Didactic SE.

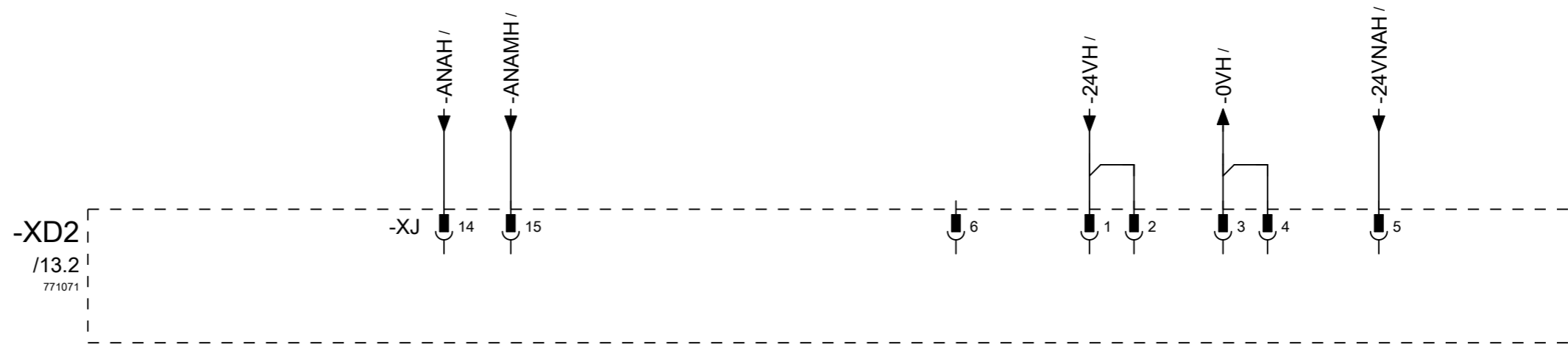

<<1

13>>

Date	12.01.2021	Festo Didactic SE
Ed. by.	Schuhmacher	Rechbergstraße 3
Creat.	Schuhmacher	D-73770 Denkendorf
Drw.Nr.	N:	F:

<b>FESTO</b>	Analogausgang - Reserve
	Analog Output - Reserve

S-Nr.	8088783
PSP / DPJ	VN

= E	Oven	Page 12
+ EB	OVEN	of 14

Diese Zeichnung ist Eigentum der Festo Didactic SE. This drawing is the property of Festo Didactic SE.

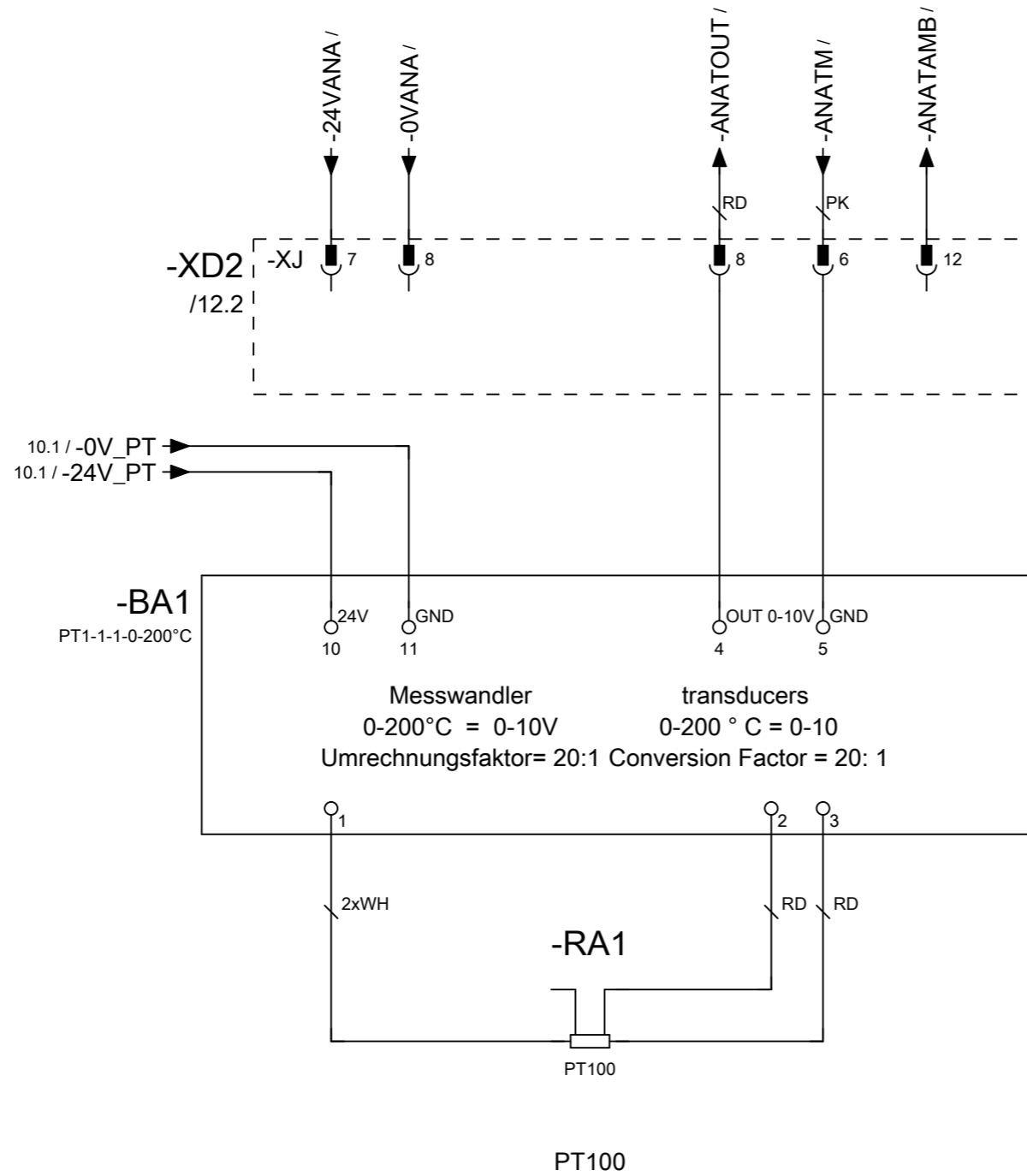

Date	12.01.2021	Festo Didactic SE	
Ed. by.	Schuhmacher	Rechbergstraße 3	
Creat.	Schuhmacher	D-73770 Denkendorf	
Drw.No.	N:	F:	EPL0VZFG7M \\Festo.net\dfs01\INT\Data\EPLAN\DATA_xx\IDE\Projects\Didactic\Products\26 CP2 AM 01.02 CP-AM-OVEN.elk



PT100 Temperaturefassung  
PT100 temperature sensing

S-Nr.	8088783
PSP / DPJ	VN

= E	Oven	Page 13
+ EB	OVEN	of 14

Diese Zeichnung ist Eigentum der Festo Didactic SE

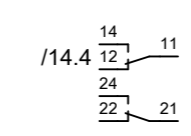
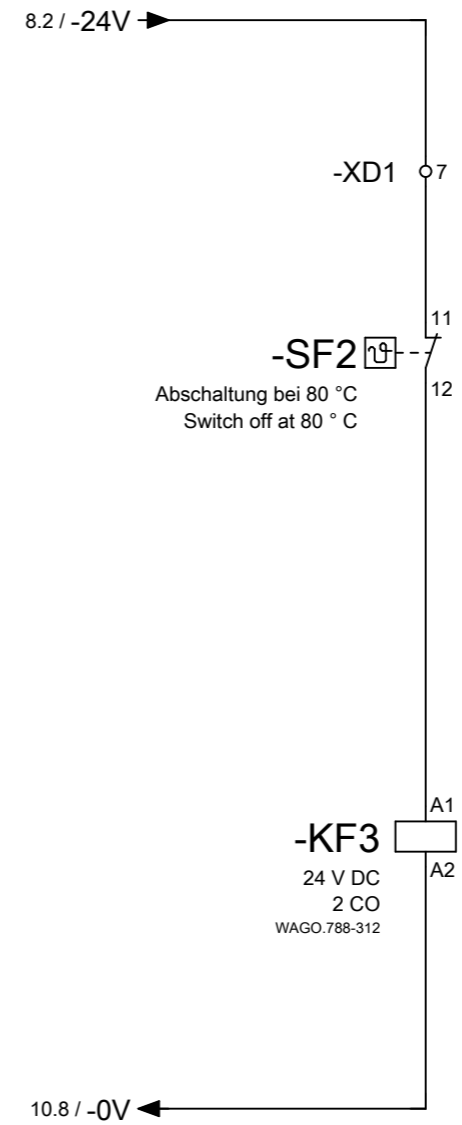
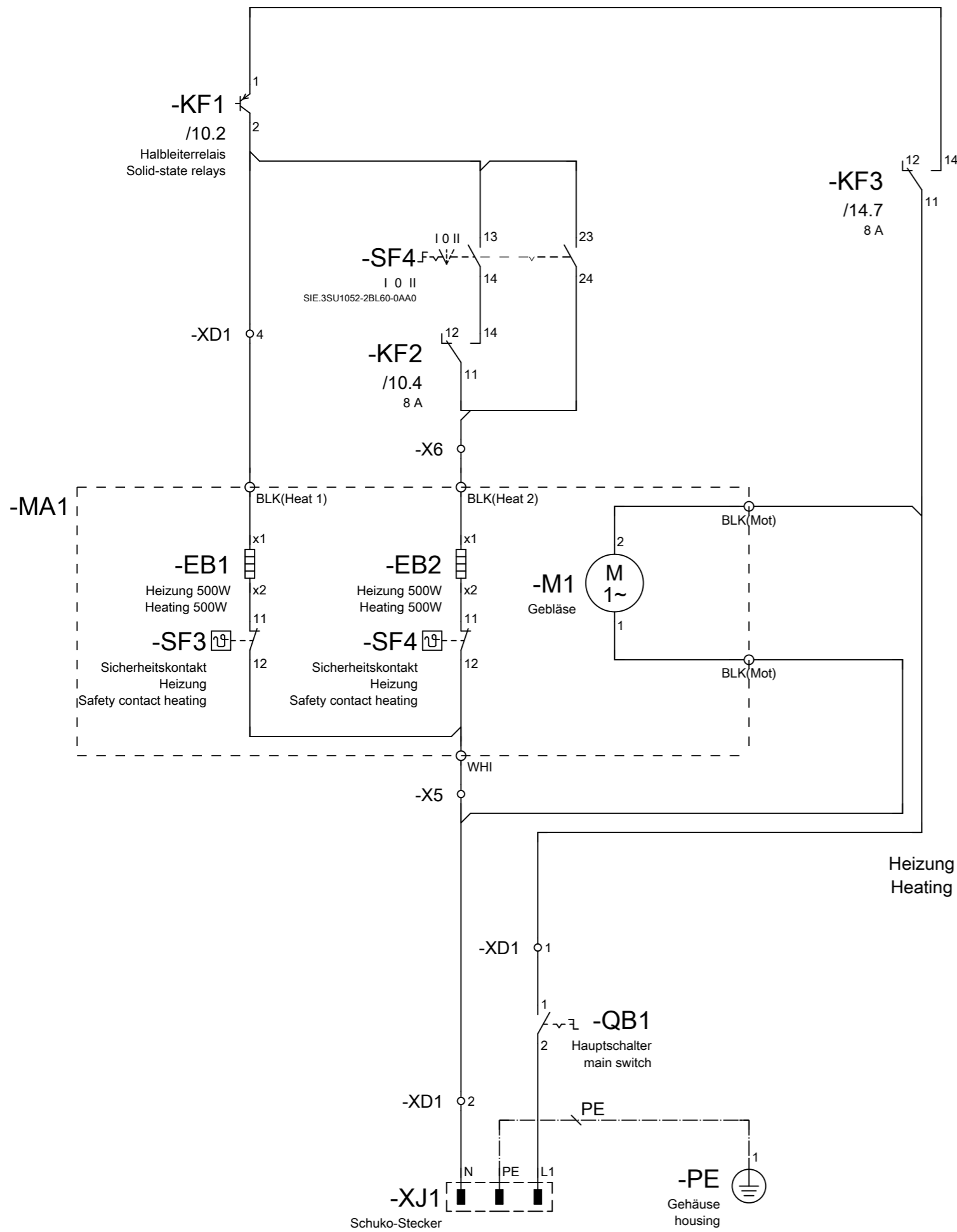

Abschaltung bei 80 °C  
Switch off at 80 ° C

<<3

>>

Date	07.04.2021	Festo Didactic SE
Ed. by.	Schuhmacher	Rechbergstraße 3
Creat.	Schuhmacher	D-73770 Denkendorf
Drw.Nr.	N:	F:

**FESTO** Heizung - 230V  
Heating - 230V

EPL0VZFG7M \\Festo.net\dfs01\INT\Data\EPLAN\DATA\_xx\IDEI\Projects\Didactic\Products\26 CP2\AM1.02 CP-AM-OVEN.elk

S-Nr.	8088783
PSP / DPJ	VN

= E	Oven	Page 14
+ EB	OVEN	of 14