

# 8173368

AS/RS for pallets

# FESTO

CP Factory/CP Lab

Original operating  
instructions

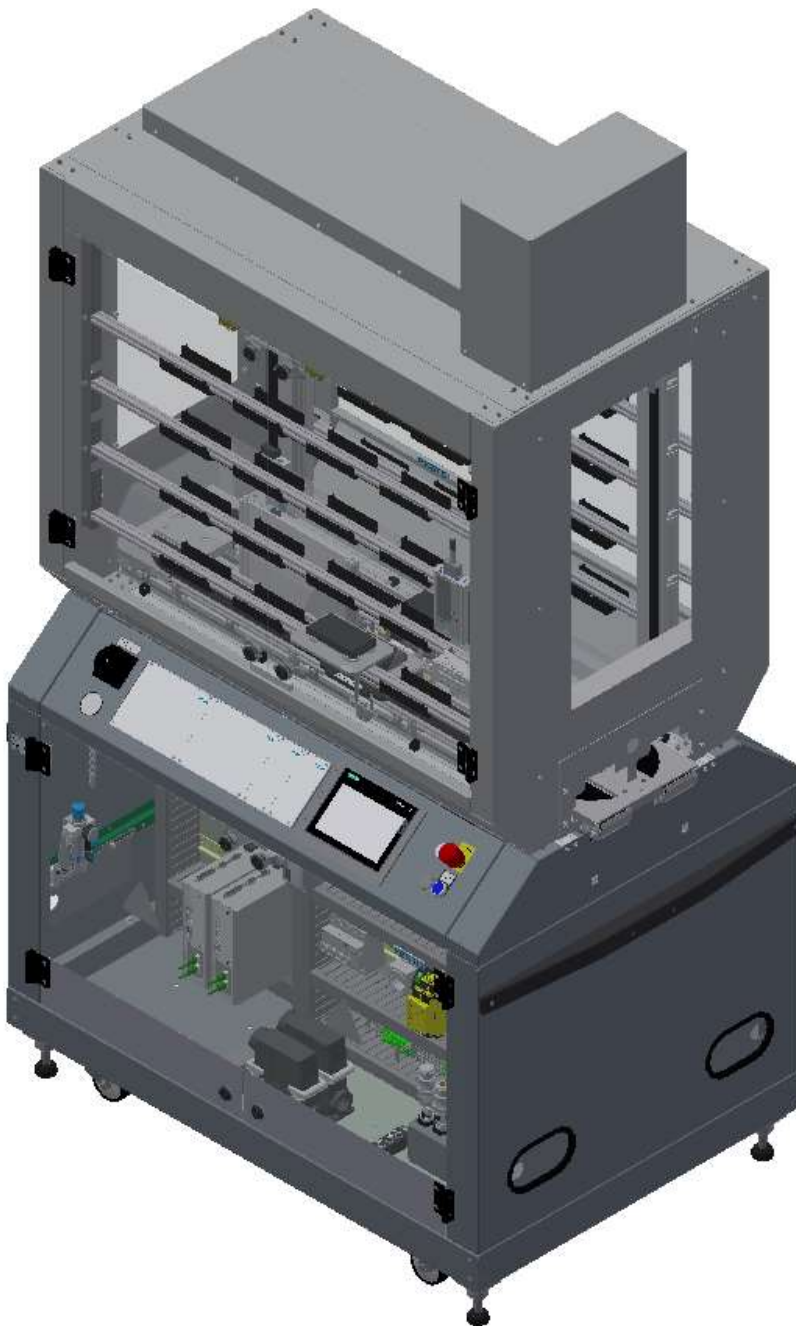

Festo Didactic  
8173368 en  
01/2023

Order number: 8173368  
Date : 01/2023  
Authors: Schober  
Layout: Frank Ebel  
File Name: CP-F-ASRS32-P-GB-8173368-A001.doc

© Festo Didactic SE, Rechbergstraße 3, 73770 Denkendorf, Germany, 2023



 +49 711 3467-0  [www.festo-didactic.com](http://www.festo-didactic.com)  
 +49 711 34754-88500  [did@festo.com](mailto:did@festo.com)

Original operating instructions

© 2023 all rights reserved to Festo Didactic SE.



Where only pronouns such as he and him are used in these operating instructions, these pronouns are of course intended to refer to both male and female persons. The use of a single gender (e.g. he, him) should not be construed as gender discrimination; it is intended solely to make the manual easier to read and the formulations easier to understand.

	 <b>CAUTION</b>
	<p>These operating instructions must be available to the user at all times. The operating instructions must be read before commissioning. The safety instructions must be observed. Non-observance may result in severe personal injury or damage to property.</p>

### Main document

Associated documents attached:

Safety instructions concerning transport (print/electronic)

Component datasheets (print/electronic)

Circuit diagram (print/electronic)

# Contents

1	Safety instructions .....	6
1.1	Warning notice system .....	6
1.2	Pictograms .....	7
1.3	General prerequisites for installing the product.....	8
1.4	General prerequisites for operating the devices .....	8
2	Intended use .....	9
3	For your safety .....	10
3.1	Important information .....	10
3.2	Qualified persons .....	11
3.3	Obligations of the operating company .....	11
3.4	Obligations of the trainees .....	11
4	Basic safety instructions .....	12
4.1	General information .....	12
4.2	Mechanical components .....	12
4.3	Electrical components .....	13
4.4	Pneumatic components.....	16
4.5	Guarantee and liability for application examples .....	18
4.6	Cyber security .....	18
4.7	Additional safety instructions .....	19
4.8	Guarantee and liability .....	20
4.9	Transport.....	21
4.10	Name plates stations .....	22
4.11	General machine safety.....	23
4.12	Protective devices .....	24
4.12.1	Panel doors on underground control cabinet .....	24
4.12.2	AS/RS20 – fixed element.....	25
4.12.3	AS/RS20 – service doors .....	25
4.12.4	Protective unit at ASRS station.....	25
4.12.5	Emergency stop.....	26
4.12.6	Additional protective devices .....	26
5	Technical data .....	27
5.1.1	Setup.....	28
6	Introduction .....	29
6.1	General information about CP Factory.....	29
6.2	Resources .....	30
7	Design and Function .....	34
7.1	Transport.....	34
7.2	Overview of the System.....	36
7.3	ASRS for pallets.....	37
7.4	Mechanical setup .....	42
7.4.1	Operating positions.....	47
7.4.2	Supply of the ASRS for pallets.....	49
7.5	Electrical installation .....	51
7.5.1	Emergency-stop structure .....	56

7.5.2	Emergency stop configuration .....	59
7.5.3	Acknowledge emergency stop after restart .....	59
7.5.4	Acknowledging emergency stop after emergency stop .....	59
7.5.5	Gripping protection tunnel .....	60
7.5.6	Electrical connection .....	61
7.6	Commissioning.....	64
7.6.1	Pneumatic commissioning.....	64
7.6.2	Electrical commissioning .....	64
7.7	Visual inspection .....	64
7.8	Adjusting the sensors.....	65
7.8.1	Proximity switch (stopper Identsensor) .....	65
7.8.2	Proximity switch (stopper cylinder) .....	67
7.8.3	Proximity switch (Z-axis cylinder) .....	69
7.8.4	Proximity switch (cylinder X-axis) .....	71
7.8.5	Proximity switch (Rotary cylinder C-axis).....	73
7.8.6	Proximity switch (cylinder Y-axis) .....	75
7.8.7	Proximity switch (gripper) .....	77
7.8.8	Through-beam sensor (Shelf detection) .....	79
7.9	Adjusting the one-way flow control valves .....	81
8	Operation .....	84
8.1	The control units of the ASRS for pallets .....	84
8.2	Sequence description stopper of the Basic Module .....	85
8.3	Sequence description of the ASRS for pallets .....	87
8.4	Menu architecture from Panel .....	89
8.5	Operation modes .....	92
8.5.1	Mode .....	92
8.5.2	Operation mode Reset.....	95
8.5.3	Operation mode Setup .....	96
8.5.4	Operation mode automatic .....	111
8.5.5	Main menu - Home .....	112
8.5.6	Main menu - Setup .....	119
8.5.7	Main menu – Parameter .....	119
8.5.8	Main menu – System .....	123
8.6	Switching on the station.....	131
8.6.1	Start automatic.....	132
8.6.2	Sequence Description Automatic .....	135
8.6.3	Process description Cycle End .....	136
8.7	Manually describe the RFID tag .....	137
8.7.1	Parameter (ASRS32) .....	139
8.7.2	Default parameter (ASRS32) .....	141
9	Components.....	142
9.1	Electrical components .....	142
9.1.1	2 Quadrant Controller.....	142
9.1.2	Servo Controller .....	146
9.1.3	Servo motors .....	147
9.2	PLC .....	148
9.2.1	Touch Panel.....	149

9.3 Scalance Ethernet Switch .....	150
9.4 RFID with Ethernet.....	153
9.4.1 Electronic circuit protection.....	156
9.4.2 Mini Terminal .....	158
9.4.3 SYS link interface .....	161
9.5 Mechanic components .....	162
9.5.1 Motor of Conveyor.....	162
9.5.2 The stopper unit .....	163
9.5.3 Transportation of the station.....	165
9.5.4 Operation panel working position .....	166
10 Message texts and interactive error messages at the HMI .....	168
10.1 Message texts .....	169
10.2 Interactive error messages.....	170
10.2.1 Default operation .....	170
10.2.2 MES Operation .....	171
10.2.3 General.....	171
10.2.4 ASRS for pallets / ASRS 32.....	172
11 Service and cleaning .....	173
12 Further information and updating .....	174
13 Disposal .....	175



# 1 Safety instructions



## 1.1 Warning notice system



These operating instructions contain notes that must be observed for your personal safety and in order to prevent property damage. The notes concerning your personal safety are indicated by a safety symbol.

Notes that only concern property damage are not indicated by a safety symbol.

The notes below are listed in order of hazard level.

	 <b>DANGER</b>
	<p>... indicates an <b>imminently</b> hazardous situation that will result in fatal or severe personal injury if not avoided.</p>

	 <b>WARNING</b>
	<p>... indicates a <b>potentially</b> hazardous situation which may result in fatal or severe personal injury if not avoided.</p>

	 <b>CAUTION</b>
	<p>... indicates a <b>potentially</b> hazardous situation that may result in moderate or slight personal injury or severe property damage if not avoided.</p>

	<b>NOTE</b>
	<p>... indicates a <b>potentially</b> hazardous situation that may result in property damage or loss of function if not avoided.</p>

In cases where more than one hazard level applies, the safety note with the highest hazard level will be shown. A safety note may concern both personal injury and property damage.

Hazards that will only result in property damage are indicated with the word "Note".

## 1.2 Pictograms

This document and the hardware described in it include warnings concerning possible hazards which may arise if the system is used incorrectly.

The following pictograms are used:



Hazard warning



Warning - dangerous electric voltage



Read and observe the operating and safety instructions prior to commissioning.



Switch off the device and unplug the connection for power supply from the plug socket before commencing installation, repair, maintenance or cleaning work.



Warning – hand injuries



Warning – risk of entanglement



Warning – lifting heavy loads



Electrostatically sensitive devices



Information and/or references to other documentation

### 1.3 General prerequisites for installing the product

- Festo Didactic products must only be used for the applications specified in their respective operating instructions. Products or components supplied by other manufacturers must only be used if recommended or approved by Festo.
- The products must be transported, stored, installed, assembled, commissioned, operated and maintained properly in order to ensure their safe operation.
- The approved ambient conditions must be observed. The specifications in the relevant operating instructions must be observed.
- The safety equipment must be tested every working day.
- Connecting cables must be checked for damage before each use. In case of damage, they must be replaced.

Connecting cables must correspond to the minimum specifications.

### 1.4 General prerequisites for operating the devices

General requirements for safe operation of the system:

- In industrial facilities, the national accident prevention regulations must be observed.
- The laboratory or classroom must be overseen by a supervisor.
  - A supervisor is a qualified electrician or a person who has been trained in electrical engineering, knows the respective safety requirements and safety regulations, and whose training has been documented accordingly.

The laboratory or the classroom must be equipped with the following devices:

- An emergency-off device must be provided.
  - At least one emergency-off device must be located inside the laboratory or the classroom, and at least one outside it.
- The laboratory or classroom must be secured so that the operating voltage and compressed air supply cannot be activated by any unauthorized persons, for example by means of:
  - e.g. a keyswitch
  - e.g. lockable shut off valves
- The laboratory or classroom must be protected by residual current devices (RCDs).
  - RCDs with a differential current of  $\leq 30$  mA, Type B. When operating machinery with unavoidable leakage current, suitable measures must be implemented and documented in the corresponding workplace risk assessment.
- The laboratory or classroom must be protected by overcurrent protection devices.
  - Fuses or circuit breakers
- Devices must not be used if they are damaged or defective.
  - Damaged devices must be barred from further use and removed from the laboratory or classroom.
  - Damaged connecting cables, pneumatic tubing and hydraulic hoses represent a safety risk and must be removed from the laboratory or classroom.
- Safety devices must be checked every working day to ensure that they are fully functional.
- Connecting cables and accessories must be checked for damage before each use.



## 2 Intended use

Festo Didactic systems and components must only be used:

- For their intended use in teaching and training applications
- When their safety functions are in perfect condition

The components and systems are designed in accordance with the latest technology and recognized safety rules. However, life and limb of the user and third parties may be endangered and the components may be impaired if they are used incorrectly.

The Festo Didactic learning system has been developed and produced exclusively for education and training in the field of automation technology. The training company and/or trainers must ensure that all trainees observe the safety precautions described in these operating instructions.

Training with complex machinery is a highly hazardous activity. The operating company must draw up and document a workplace risk assessment. The trainees must be briefed on all the relevant safety aspects before work commences.

**Festo Didactic hereby excludes any and all liability for damages suffered by apprentices, the training company and/or any third parties, which occur during use of the device in situations which serve any purpose other than training and/or vocational education, unless such damages have been caused by Festo Didactic due to malicious intent or gross negligence.**

All extensions and accessories must be approved by Festo Didactic, and are only permitted for use for their intended purpose.

The machine fulfils the requirements of the European directives that applied when it was commissioned. Any modification to the machine shall render the manufacturer's CE Declaration of Conformity null and void. The CE Declaration of Conformity must be renewed following each major modification.



## 3 For your safety

### 3.1 Important information

Knowledge of the basic safety instructions and safety regulations is a fundamental prerequisite for safe handling and trouble-free operation of Festo Didactic components and systems.

These operating instructions include the most important instructions for safe use of the components and systems. In particular, the safety instructions must be adhered to by all persons who work with these components and systems. Furthermore, all pertinent accident prevention rules and regulations that are applicable at the respective place of use must be adhered to.

	 <b>WARNING</b>
	<ul style="list-style-type: none"><li>• <b>Malfunctions which could impair safety must be eliminated immediately!</b></li></ul>

	 <b>CAUTION</b>
	<ul style="list-style-type: none"><li>• <b>Improper repairs or modifications may result in unforeseeable operating statuses. Do not carry out any repair or alternation work on components or systems that is not described in these operating instructions.</b></li></ul>

### 3.2 Qualified persons

- The product described in these operating instructions is only permitted for operation by persons who are qualified for the task in question in accordance with the operating instructions, especially the safety instructions.
- Qualified persons are defined as persons whose training and experience enables them to recognize risks and avoid potential dangers when working with this product.

### 3.3 Obligations of the operating company

It is the responsibility of the operating company to ensure that the station is operated safely.

The operating company undertakes to allow only those persons to work with the components and systems who:

- Are familiar with the basic regulations regarding occupational safety, with the safety instructions, and with the accident prevention regulations, and who have been instructed in the use of the components and systems
- Have read and understood the safety chapter and warnings in these operating instructions
- Are qualified to operate the components and systems in question
- Are governed by and trained in suitable organizational measures to ensure safe training

Personnel should be tested at regular intervals to ensure that they are safety-conscious in their work habits.



### 3.4 Obligations of the trainees

All persons who have been entrusted to work with the components and systems undertake to complete the following steps before beginning work:



- Read the chapter concerning safety and the warnings in these operating instructions
- Familiarize themselves with the basic regulations regarding occupational safety and accident prevention



## 4 Basic safety instructions

### 4.1 General information



	 <b>CAUTION</b>
	<ul style="list-style-type: none"> <li>• <b>Trainees must be supervised by an instructor at all times when working with the components and systems.</b></li> <li>• <b>Observe the specifications included in the technical data for the individual components, and in particular all the safety instructions!</b></li> <li>• <b>Wear your personal protective equipment (safety goggles, safety shoes).</b></li> <li>• <b>Never leave objects lying on the top of protective enclosures. Vibrations could cause such objects to fall off.</b></li> </ul>



### 4.2 Mechanical components



	 <b>WARNING</b>
	<ul style="list-style-type: none"> <li>• <b>Switch off the power supply!</b> <ul style="list-style-type: none"> <li>– Switch off both the operating power and the control power before commencing work on the circuit.</li> <li>– Never reach into the setup unless it is at a complete standstill.</li> <li>– Be aware of potential overtravel times for the actuators.</li> </ul> </li> <li>• <b>Risk of injury during troubleshooting!</b> <ul style="list-style-type: none"> <li>– Use a tool such as a screwdriver for actuating sensors.</li> </ul> </li> </ul>

	 <b>CAUTION</b>
	<ul style="list-style-type: none"> <li>• <b>Risk of burns due to hot surfaces</b> <ul style="list-style-type: none"> <li>– Devices can reach high temperatures during operation, as a result of which they can cause burns if touched.</li> </ul> </li> <li>• <b>Measures to take when maintenance is required.</b> <ul style="list-style-type: none"> <li>– Allow the device to cool off before commencing work.</li> <li>– Use suitable personal protective clothing, e.g. safety safety gloves.</li> </ul> </li> </ul>

### 4.3 Electrical components

	 <b>DANGER</b>
	<ul style="list-style-type: none"><li>• <b>Risk of fatal injury in case of interrupted protective grounding conductor!</b><ul style="list-style-type: none"><li>– The protective grounding conductor (yellow-green) must not be interrupted, either inside or outside of the device.</li><li>– The insulation of the protective grounding conductor must never be damaged or removed.</li></ul></li><li>• <b>Risk of death from connecting power supply units in series!</b><p>Contact voltages of greater than 25 V AC or 60 V DC are not permissible. Contact with voltages of greater than 50 V AC or 120 V DC may be fatal.</p><ul style="list-style-type: none"><li>– Do not connect power supplies in series.</li></ul></li><li>• <b>Risk of death due to electric shock!</b><p>Protect the outputs of the power supplies (output sockets/terminals) and cables connected to them from direct contact.</p><ul style="list-style-type: none"><li>– Always use connector cables with adequate insulation and electric strength.</li><li>– Use safety sockets with fully shrouded contact points.</li></ul></li></ul>



	 <b>WARNING</b>
	<ul style="list-style-type: none"> <li>• <b>Disconnect from all sources of electrical power!</b> <ul style="list-style-type: none"> <li>– Switch off the power supply before working on the circuit.</li> <li>– Please note that electrical energy may be stored in individual components. Further information on this issue is available in the datasheets and operating instructions included with the components.</li> <li>– <b>Warning!</b> Capacitors inside the device may still be charged even after being disconnected from all sources of voltage.</li> </ul> </li> <li>• <b>Danger due to malfunction</b> <ul style="list-style-type: none"> <li>– Never place or leave liquids (e.g. drinks) on the station in open containers.</li> <li>– The machine must not be switched on if there is condensation (moisture) on its surface.</li> <li>– Never lay pipes/hoses designed to carry liquid media near the machine.</li> </ul> </li> <li>• <b>Electric shock due to connection to unsuitable power supply!</b> <ul style="list-style-type: none"> <li>– When devices are connected to an unsuitable power supply, exposed components can cause dangerous electrical voltage that can lead to severe or fatal injury.</li> <li>– Always use power supplies that provide SELV (safety extra-low voltage) or PELV (protective extra-low voltage) output voltages for all the connections and terminals on the electronics modules.</li> </ul> </li> <li>• <b>Electric shock when there is no protective grounding in place</b> <ul style="list-style-type: none"> <li>– If there is no protective grounding terminal in place for a Protection Class I device, or if the protective grounding terminal has not been installed correctly, exposed, conductive parts may carry high voltages, thus causing severe or fatal injury if touched.</li> <li>– Ground the device in accordance with the applicable regulations.</li> </ul> </li> </ul>

	 <b>WARNING</b>
	<ul style="list-style-type: none"> <li>• <b>Risk of fire due to use of unsuitable power supply</b> <ul style="list-style-type: none"> <li>– If a device is connected to an unsuitable power supply, this can cause components to overheat, leading to a breakout of fire.</li> <li>– Always use limited power supplies (LPSs) for all the connections and terminals on the electronics modules.</li> </ul> </li> </ul>



**CAUTION**

- **Always ensure that your connecting cables are designed for use with the electrical connections in question.**
- **When laying connecting cables, make sure they are not kinked, sheared or pinched. Cables laid on the floor must be covered with a cable bridge to protect them.**
- **Do not lay cables over hot surfaces.**
  - Hot surfaces are identified with a corresponding warning symbol.
- **Make sure that connecting cables are not subjected to continuous tensile loads.**
- **Devices with a grounding terminal must always be grounded.**
  - If a ground connection (green-yellow laboratory socket) is available, it must always be connected to the protective grounding. The protective grounding must always be connected first (before voltage) and disconnected last (after disconnecting the voltage).
  - Some devices have high leakage current. These devices must be fitted with a grounding conductor for additional grounding.
- **When replacing fuses, always use specified fuses with the correct current rating and tripping characteristics.**
- **The device is not equipped with a built-in fuse unless otherwise specified in the technical data.**
- **Safe operation of the device is not possible in the event of any of the following circumstances:**
  - Visible damage
  - Malfunction
  - Inappropriate storage
  - Incorrect transport
- **Switch off the power supply immediately.**
- **Protect the device to prevent it from being restarted accidentally.**

#### 4.4 Pneumatic components

	 <b>WARNING</b>
	<ul style="list-style-type: none"><li>• <b>Depressurize the system!</b><ul style="list-style-type: none"><li>– Switch off the compressed air supply before working on the circuit.</li><li>– Check the system using pressure gauges to make sure that the entire circuit is fully depressurized.</li><li>– Please note that energy may be stored in reservoirs. Further information on this issue is available in the datasheets and operating instructions included with the components.</li></ul></li><li>• <b>Risk of injury when switching on compressed air!</b><ul style="list-style-type: none"><li>– Cylinders may advance and retract automatically.</li></ul></li><li>• <b>Risk of accident due to advancing cylinders!</b><ul style="list-style-type: none"><li>– Always position pneumatic cylinders so that the piston rod's working space is unobstructed along its entire stroke range.</li><li>– Make sure that the piston rod cannot collide with any of the rigid components in the setup.</li></ul></li><li>• <b>Risk of accident due to pneumatic tubing slipping off!</b><ul style="list-style-type: none"><li>– Use shortest barbed tubing connectors possible.</li><li>– If pneumatic tubing slips off, switch off the compressed air supply immediately.</li></ul></li><li>• <b>Do not exceed the maximum permissible pressure of 600 kPa (6 bar).</b></li><li>• <b>Do not switch on the compressed air until all the barbed tubing connectors have been connected and secured.</b></li><li>• <b>Do not disconnect pneumatic tubing while it is under pressure.</b><ul style="list-style-type: none"><li>– Do not attempt to seal or plug pneumatic tubing or plug connectors with your hands or fingers.</li></ul></li><li>• <b>Check the condition of the condensate in the service unit regularly. If necessary, drain the condensate and dispose of it properly.</b></li></ul>



 <b>CAUTION</b>	
	<ul style="list-style-type: none"><li>• <b>Setting up pneumatic circuits</b><ul style="list-style-type: none"><li>– Connect the devices with plastic tubing with an outside diameter of 4 or 6 mm.</li><li>– Push the pneumatic tubing into the push-in connector as far as it will go.</li></ul></li><li>• <b>Dismantling pneumatic circuits</b><ul style="list-style-type: none"><li>– Switch off the compressed air supply before dismantling the circuit.</li><li>– Press the blue release ring down so that the tubing can be pulled out.</li></ul></li><li>• <b>Noise due to escaping compressed air</b><ul style="list-style-type: none"><li>– Noise caused by escaping compressed air may damage your hearing. Reduce noise by using mufflers, or wear hearing protection if the noise cannot be avoided.</li><li>– All of the exhaust ports on the components included in the equipment set are equipped with mufflers. Do not remove these mufflers.</li></ul></li></ul>

#### 4.5 Guarantee and liability for application examples

The application examples are not legally binding, and we cannot guarantee their completeness in terms of their configuration, their equipment or any events that may occur. The application examples are not representations of any specific customer solution; they are merely intended to illustrate typical tasks for which the product in question could be used. You bear the responsibility for ensuring that the products described here are operated properly. These application examples do not in any way relieve you of your responsibility to ensure that the system is handled safely when it is being used, installed, operated or maintained.



#### 4.6 Cyber security

##### Note

Festo Didactic offers products with industrial security functions that aid the safe operation of plants, systems, machines and networks. In order to protect plants, systems, machines and networks from cyber threats, a comprehensive industrial security concept must be implemented and continuously updated.

Festo's products and services only constitute one part of such a concept.

The customer is responsible for preventing unauthorized access to their plants, systems, machines and networks. Systems, machines and components should only be connected to a company's network or the Internet if and as necessary, and only when the suitable security measures (e.g. firewalls and network segmentation) are in place. Furthermore, Festo's guidelines on suitable security measures should be observed. Festo products and solutions are constantly being developed further in order to make them more secure. Festo strongly recommends that customers install product updates as soon as they become available and always use the latest versions of its products. Any use of product versions that are no longer supported or any failure to install the latest updates may render the customer vulnerable to cyber attacks.

	 <b>WARNING</b>
	<ul style="list-style-type: none"> <li>• <b>Unsecure operating conditions due to software tampering</b> <ul style="list-style-type: none"> <li>– Forms of software tampering (e.g. viruses, Trojans, malware and worms) can lead to unsecure operating conditions in your system, which may in turn lead to severe or fatal injury or property damage.</li> <li>– Keep your software up to date.</li> <li>– Integrate the automation and actuator components into an overarching and comprehensive industrial security concept for the installation or machine in question that is in line with the latest technological developments.</li> <li>– Make sure that all the products you have installed are incorporated into your overarching industrial security concept.</li> <li>– Use suitable measures, such as a virus scanner, to protect files save on exchangeable storage media from malware.</li> </ul> </li> </ul>

#### 4.7 Additional safety instructions

General requirements for safe operation of the devices:

- Do not lay cables over hot surfaces.
  - Hot surfaces are identified with a corresponding warning symbol.
- Maximum permissible current loads for connector cables and devices must not be exceeded.
  - Always compare the current ratings of the device, the cable and the fuse to ensure that they match.
  - If they do not match, use a separate upstream fuse in order to provide appropriate overcurrent protection.
- Devices with a grounding terminal must always be grounded.
  - If a ground terminal (green-yellow laboratory socket) is available, it must always be connected to protective ground. The protective grounding must always be connected first (before voltage) and disconnected last (after disconnecting the voltage).
- The device is not equipped with a built-in circuit unless otherwise specified in the technical data.





	<p data-bbox="756 797 1027 853" style="text-align: center;"> <b>WARNING</b></p> <ul style="list-style-type: none"><li>• <b>This product is designed for use in industrial environments, and may cause malfunctions if used in domestic or small commercial environments.</b></li></ul>
---	---

#### **4.8 Guarantee and liability**

Our General Terms and Conditions of Sale and Delivery shall apply at all times. These shall be made available to the operating company no later than upon conclusion of the sales contract. Guarantee and liability claims resulting from personal injury and/or property damage are excluded if they can be traced back to one or more of the following causes:

- Use of the equipment for purposes other than its intended use
- Improper installation, commissioning, operation or maintenance of the system
- Operation of the system with defective safety equipment, or with improperly attached or non-functional safety equipment and protective guards
- Non-compliance with directions included in the operating instructions with regard to transport, storage, installation, commissioning, operation, maintenance and setup of the system
- Unauthorized modifications to the system
- Improperly executed repairs
- Disasters resulting from the influence of foreign bodies and acts of God
- Dust generated during construction work must be kept away from the system (use coverings).  
See the Environmental Requirements section (contamination level) for more details.

## 4.9 Transport

	<div style="background-color: #c85130; color: white; padding: 5px; text-align: center;">  <b>WARNING</b> </div> <ul style="list-style-type: none"> <li>• <b>Danger due to tipping over</b> <ul style="list-style-type: none"> <li>– Suitable packaging and transport equipment must be used when transporting the station. The station can be lifted from underneath using a forklift truck. Please note that eccentric centers of gravity can cause the station to tip over.</li> <li>– Stations with attachments at height will have a high center of gravity.</li> <li>– Take care to avoid tipping over during transportation.</li> </ul> </li> </ul>
	<div style="background-color: #f9c94d; color: black; padding: 5px; text-align: center;">  <b>CAUTION</b> </div> <ul style="list-style-type: none"> <li>• <b>Danger due to broken castors!</b>        The castors on the device are not designed to be used for transportation. The castors are designed merely for positioning the station. The screw feet must relieve the castors of all the station's weight before commissioning begins. The screw feet must be set so that the station is horizontal and aligned at the same height as its neighboring station.       <ul style="list-style-type: none"> <li>– Safety shoes must be worn when transporting the station!</li> </ul> </li> </ul>
	<div style="background-color: #0056b3; color: white; padding: 5px; text-align: center;"> <b>NOTE</b> </div> <ul style="list-style-type: none"> <li>• <b>Station contains delicate components!</b> <ul style="list-style-type: none"> <li>– Take care not to shake during transportation</li> <li>– The station is only permitted for installation on solid, non-vibrating surfaces.</li> <li>– Make sure that the ground underneath the station has sufficient load-bearing capacity.</li> </ul> </li> </ul>

#### 4.10 Name plates stations

1 **CP-F-LINEAR-C42**

2 Mat.-Nr.: **xxxxxxx**

3 Auftrag: **aaaaaaaaa M306 2020**

4 **3AC 400V 50/60 Hz**

5 **I=1A SCCR=10kA p=6 bar 90 psi**

6  **3S7PNLMDTQG**

7 **Festo Didactic SE**  
**Rechbergstrasse 3**  
**DE-73770 Denkendorf**



 9

 8

Name plate example



Position	Description
1	Description / Configuration
2	Intern material number
3	Order number, charge code, year of construction
4	Data electrical connection
5	Current consumption, short-circuits strength, input pressure compressed air (bar / psi)
6	Unique-ID, unique machine identification
7	Manufacturer's address
8	Data matrix code of a link to the website of the product
9	CE Identification

#### 4.11 General machine safety

	 <b>WARNING</b>
	<ul style="list-style-type: none"><li>• <b>General machine safety, CE conformity</b><ul style="list-style-type: none"><li>– The individual modules of this system contain control programs for which the safety of the machine has been evaluated.</li><li>– The safety-related parameters and checksums of the safety function are listed in the operating instructions for the respective stations.</li><li>– Changes to programs may impair the safety of the machine. A modified control program may constitute a major change to the machine.</li><li>– In such cases, the manufacturer's CE Declaration of Conformity shall be rendered null and void. The operating company will need to re-evaluate the safety of the machine and confirm its CE conformity.</li></ul></li></ul>

#### 4.12 Protective devices

In order to reduce risks, this machine contains guards to prevent access to dangerous areas. These guards must not be removed or tampered with.

 <b>WARNING</b>	
	<ul style="list-style-type: none"><li>• <b>Damage to the safety window</b><ul style="list-style-type: none"><li>– Windows must not be cleaned using aggressive or alcoholic cleaning agents. Risk of brittleness and breakage!</li><li>– This protective device must be replaced if it shows any signs of damage. Please contact our Service department to arrange this.</li></ul></li></ul>

##### 4.12.1 Panel doors on underground control cabinet

Transparent, impact-resistant, polycarbonate plate with lock.

Can only be accessed with tool (control cabinet key); tool must be kept in a secure place!

Access reserved for qualified electricians.

The safety door is not monitored! Make sure the safety door is always closed.

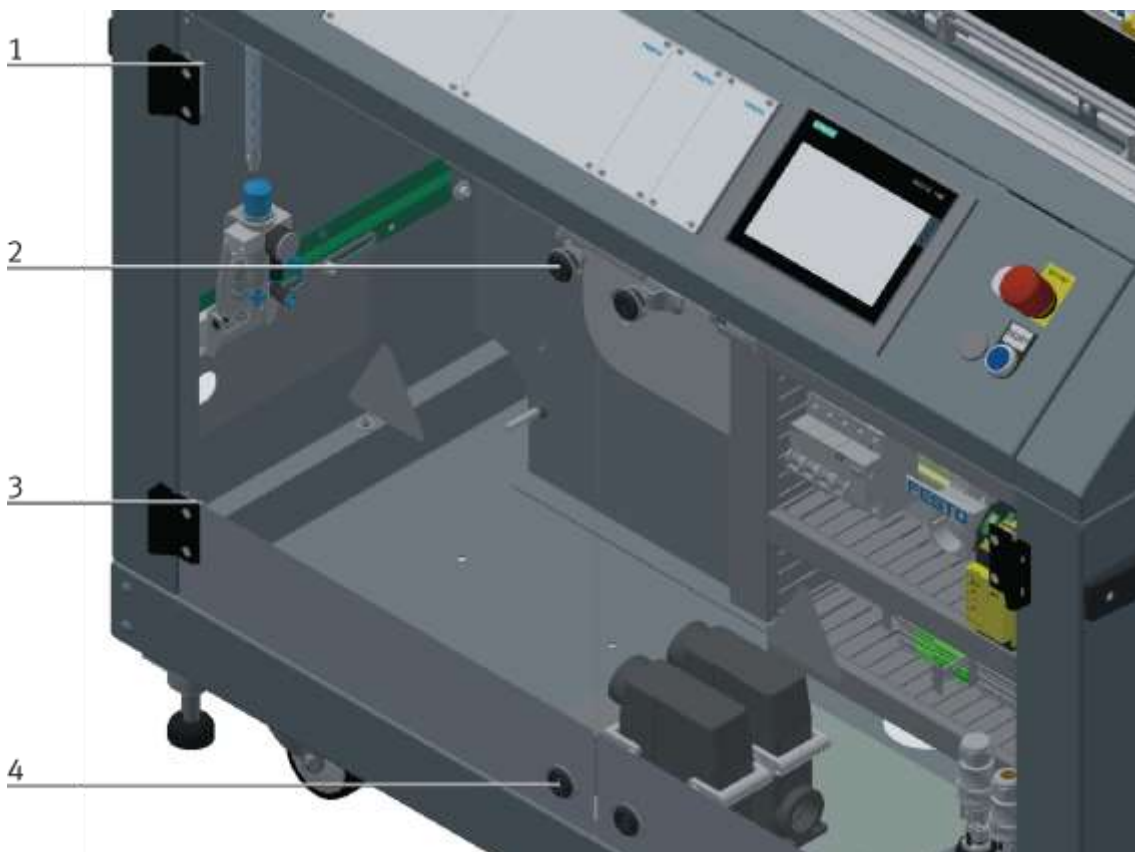

Illustration similar

The hinges of the control cabinet doors are provided with spring steel sheets (1). If the switch cabinet locks (2) are not locked, the door is automatically opened a crack and reminds the user to firmly lock the door with the switch cabinet locks.



#### 4.12.2 AS/RS20 – fixed element

Transparent, impact-resistant, polycarbonate plate on sides and top

#### 4.12.3 AS/RS20 – service doors

Transparent, impact-resistant, polycarbonate plate

Can be opened for service purposes.

Fitted with safety switches, 2-channel

Automatic operation only possible when door closed

#### 4.12.4 Protective unit at ASRS station

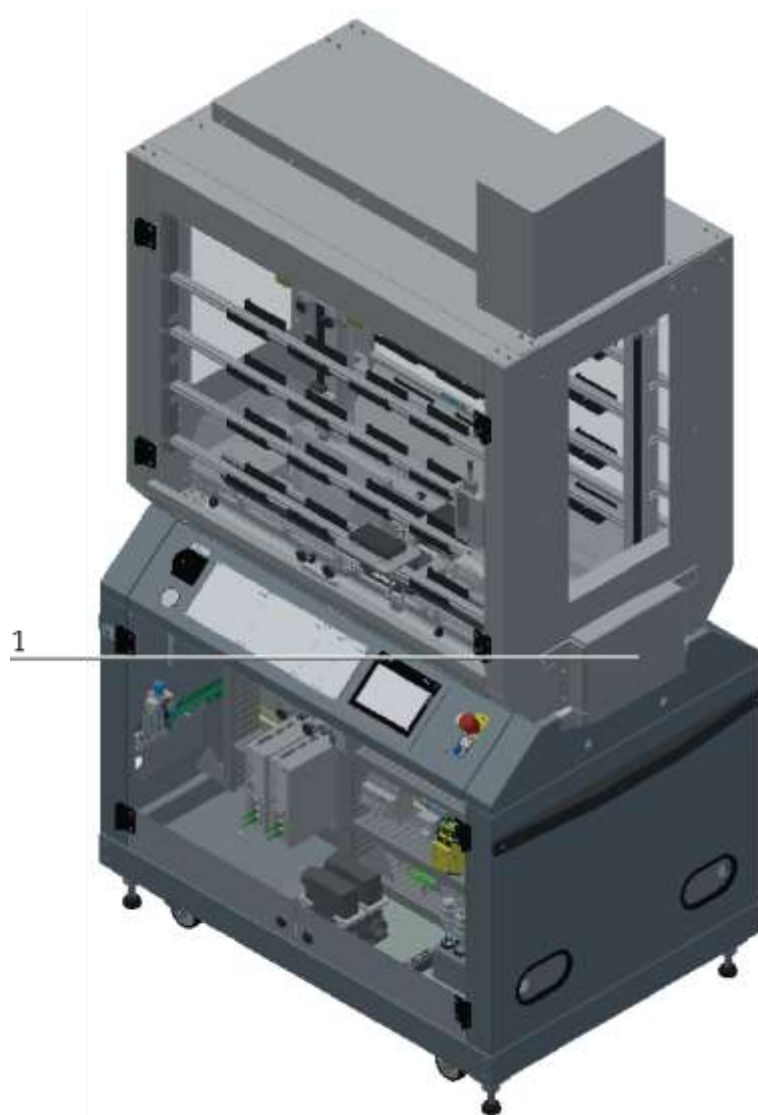

Illustration similar

1. If no other station is installed and the workpiece carriers are not transferred to a following station, the protective unit must be installed to prevent access to the station. This applies to both sides of the station.

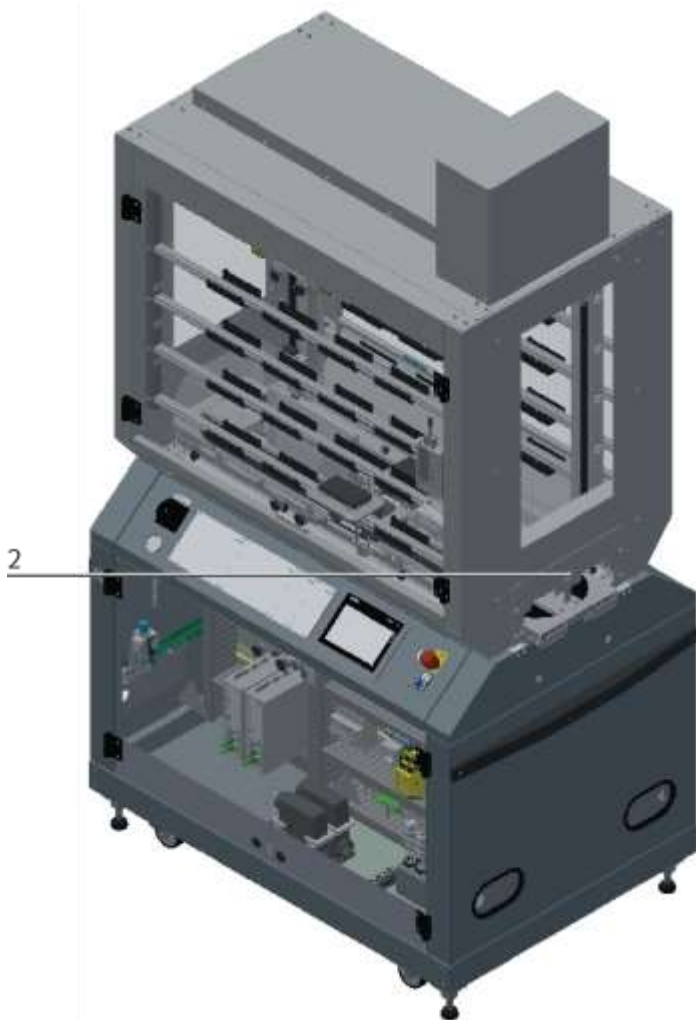

Illustration similar

2. If another station is installed and the workpiece carriers are transferred to a following station, the protective unit of the station must be removed. This applies to both sides of the station.

#### **4.12.5 Emergency stop**

Every station contains an emergency stop mushroom actuator. All the emergency stop actuators in the system are interconnected. The emergency stop signal shuts off all the actuators. Operator confirmation is required to restart the system; there is no automatic restart.

#### **4.12.6 Additional protective devices**

The individual components, such as the power supplies and the controllers, possess built-in safety functions such as short-circuit protection, overcurrent protection, overvoltage protection and thermal monitoring. If necessary, consult the instruction manual for the device in question for more information.

## 5 Technical data

Parameter	Value
<b>Electrics</b>	
Operating voltage	3-phase 400 V AC±10%, 50 Hz
Power supply system	TNC-S, mains conductor L1, L2, L3, neutral conductor N, protective grounding PE
Full load power	2 A
Control voltage, Voltage for small actuators	24 V DC Protective extra-low voltage (PELV)
Power supply connection	IEC 60309, CEE 16 A
Max. backup fuse for installation	16 A
Leakage current	≤ 18 mA
Connecting cable between stations	System plug
Protection class	I, Operation with protective grounding only. Second protective grounding conductor required due to high leakage current
Overvoltage category	CAT II, Operation in building installation only
Short circuit current rating (SCCR)	10 kA
<b>Compressed air</b>	
Supply pressure	6 bar, 90 psi
Supply rate	≥ 40 l/min
Compressed air quality	EN ISO 8573-1
Pressure dew point (Class 4)	≤ +3°C
<b>Ambient conditions</b>	
Operating environment	Use inside building only
Ambient temperature	5°C ... 40°C
Rel. air humidity	80% up to 31°C
Pollution degree	2, Dry, non-conductive contamination
Operating height	Up to 2000 m above NN (sea level)
Noise emission level	L <sub>pA</sub> < 70 dB
<b>Certification</b>	
CE marking in accordance with:	Machinery Directive EMC Directive RoHS Directive
EMC environment	Industrial environment, Class A (in acc. with EN 55011)
<b>Subject to change</b>	

### 5.1.1 Setup

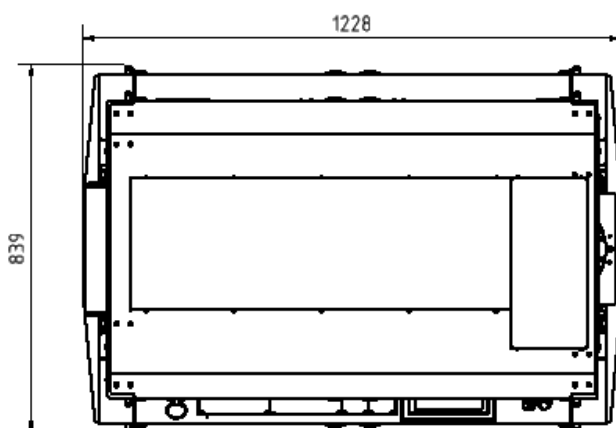
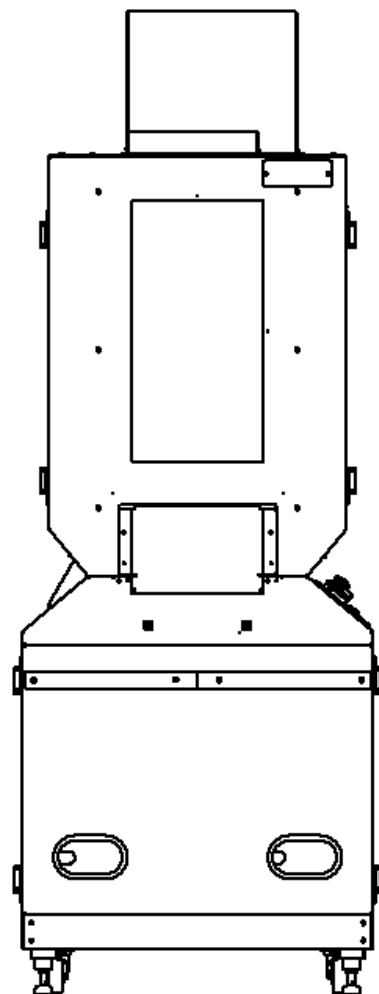
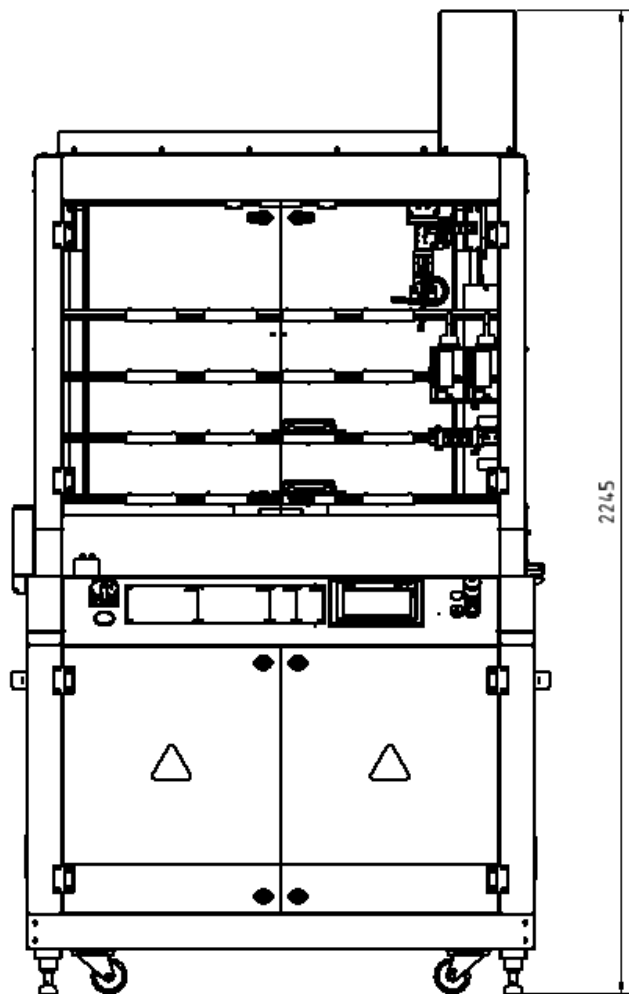

Illustration similar

Recommended minimum distance from the spatial limitation 1.2 m

## 6 Introduction

### 6.1 General information about CP Factory

The CP Factory has been developed in close co-operation with teachers and instructors. The result is a training system meeting all demands on modularity, mobility, flexibility and openness due to its completely new characteristics.

The station provides an appropriate system for practice-orientated tuition of the following key qualifications

- Social competence,
- Professional competence and
- Methodological competence,

Which are required in today's complex world of employment. This is much easier now with use of the CP Factory.

The two-sided symmetrical basic modules with accompanying control board and control unit are identical. With their technical system „transfer line with drive unit and stopper unit“, they are ideal for the training in SPS programming and drive technology from basics to medium level.

Due to the patented passive pallet return systems, the continuous working process „pallet circulation“ is already possible when using one single basic module.

The industrial-relevant basic process „pallet circulation“ already contains a large number of important course contents such as:

- drive technology with DC geared motor
- drive technology with asynchronous motor and converter (optional)
- drive technology with servo motor and servo converter (optional)
- pallet-stop setting
- pallet-stroke setting and pallet-indexing (optional)
- pallet identification by binary coding
- pallet identification by RFID
- speed and position recording by pulse generating disc (optional)
- basics on electro pneumatics (stop-cylinder model)
- basics on SPS programming
- SPS programming in steps
- SPS programming operating modes
- SPS programming binary coding
- SPS programming communication by frequency converter (optional)
- SPS programming communication by RFID (optional)
- SPS programming/visualization by touch panel (optional)

The basic module becomes a station by adding technology-specific application modules like magazines, handling or machining units. The standardized mechanical and electrical interface of application and basic module allows an unproblematic starting-up.

The CP Factory is a perfect platform for nearly all course contents. It helps to improve the co-operation of different teams and to extend the ability of understanding processes.

On this system, especially the topics about networking, communication and data acquisition can be shown in an easily comprehensible way and can be further trained.

## 6.2 Resources

The training equipment of the system consists of several resources. They are used depending on the process selection.

The following resources are available:



Pallet carrier / illustration similar

These pallet carriers are available for transporting the pallets.

Partnumber in MES - 31



Pallet / illustration similar

These pallets are available for receiving always one workpiece.

Partnumber in MES - 25

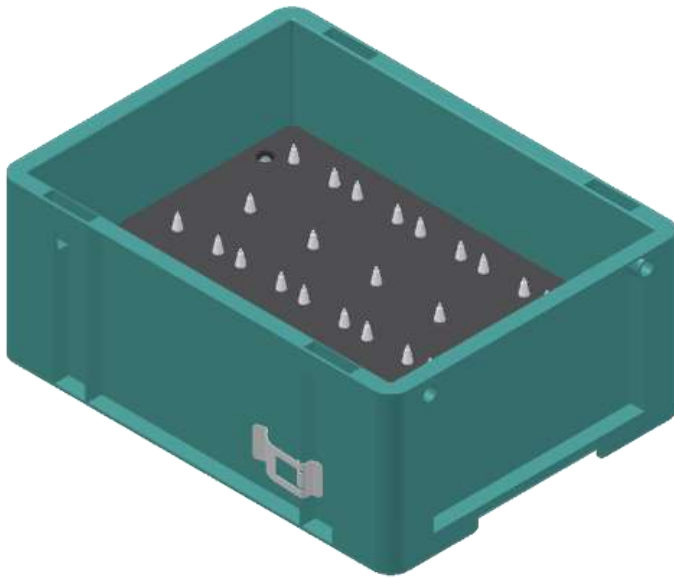

Illustration similar

Box with retainer for 10 PCB's  
Partnumber in MES – 27





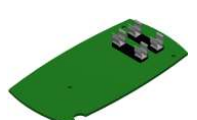













Illustration similar

Box with retainer for 8 front/backcovers or assembled workpieces  
Partnumber in MES – 28

## Workpieces

The workpieces are differentiated according to the project into production parts and external production parts.



Workpieces	Description	Workpieces	Description
	CP raw material black No. 101		CP back cover blue No. 113
	CP raw material grey No. 102		CP back cover red No. 114
	CP raw material blue No. 103		CP – board No. 120
	CP raw material red No. 104		CP fuse No. 130
	CP front cover red No. 107		CP front cover black No. 210 – if there is a CNC milling machine integrated in the system, the front cover can also be produced there, thus becoming a production part.
	CP front cover blue No. 108		CP front cover black without fuses No. 211
	CP front cover grey No. 109		CP front cover black with fuse left No. 212
	CP front cover black No. 110		CP front cover black with fuse right No. 213
	CP back cover black No. 111		CP front cover black with both fuses No. 214
	CP back cover grey No. 112		







Workpieces	Description	Workpieces	Description
	CP front cover grey No. 310 – if there is a CNC milling machine integrated in the system, the front cover can also be produced there , thus becoming a production part.		CP front cover red No. 510 – if there is a CNC milling machine integrated in the system, the front cover can also be produced there , thus becoming a production part.
	CP front cover grey without fuses No. 311		CP front cover red without fuses No. 511
	CP front cover grey with fuse left No. 312		CP front cover red with fuse left No. 512
	CP front cover grey with fuse right No. 313		CP front cover red with fuse right No. 513
	CP front cover grey with both fuses No. 314		CP front cover red with both fuses No. 514
	CP front cover blue No. 410 – if there is a CNC milling machine integrated in the system, the front cover can also be produced there , thus becoming a production part.		CP black complete without board No. 1200
	CP front cover blue without fuses No. 411		CP part customer No. 1210 freely selectable
	CP front cover blue with fuse left No. 412		CP part black with no fuse No. 1211
	CP front cover blue with fuse right No. 413		CP part black with fuse on the left No. 1212
	CP front cover blue with both fuses No. 414		CP part black with fuse on the right No. 1213
			CP part black with both fuses No. 1214

## 7 Design and Function

### 7.1 Transport

	 <b>WARNING</b>
	<ul style="list-style-type: none"> <li>• <b>Damage to transport equipment when moving heavy machines/machine sections</b> <ul style="list-style-type: none"> <li>– When the stations are shipped out, extra care must be taken to ensure that heavy machines/machine sections are always transported using a suitable forklift truck. A single station can weigh up to 500 kg.</li> <li>– Always use suitable transport equipment.</li> <li>– Always use the lifting points provided to move the machine/machine sections.</li> <li>– Always use the designated load take-up point.</li> </ul> </li> </ul>

	 <b>WARNING</b>
	<ul style="list-style-type: none"> <li>• <b>Securing transit routes</b> <ul style="list-style-type: none"> <li>– The supply routes must be cleared prior to transport, and must be suitable for the forklift truck to pass through. If necessary, warning signs or barrier tape must be set up to keep the routes clear.</li> </ul> </li> <li>• <b>Caution</b> <ul style="list-style-type: none"> <li>– When opening transport boxes, care must be taken to ensure that any additional components delivered in the same box, such as computers, do not fall out.</li> </ul> </li> </ul>

	 <b>WARNING</b>
	<ul style="list-style-type: none"> <li>• <b>Danger of crushing for hands/feet</b> <ul style="list-style-type: none"> <li>– It is not permitted to grip onto or under the feet when handling the machine, as there is an increased risk of hands or feet getting crushed or trapped in these areas.</li> <li>– When setting down the station, make sure no persons have their feet under the machine's feet.</li> </ul> </li> </ul>

**NOTE**

- When opening the transport box, any additional components must be secured to prevent them from falling out, and removed first.
- Once this is done, the transport box can be removed/opened up fully, and the station can be taken out and moved to its intended location.
- Care must be taken with all components projecting from the machine, as sensors and similar small parts can easily be damaged if the machine is not transported correctly.
- Check that all the profile connectors are seated correctly using a size 4 – 6 Allen key. Unavoidable vibrations can loosen the connectors during transport.

### 7.2 Overview of the System

CP Lab Conveyor, CP Factory Linear, CP Factory Shunt and CP Factory Bypass are called basic modules. If an application module, e.g. the CP Application Module muscle press is attached to a basic module, it becomes a station.

#### Example

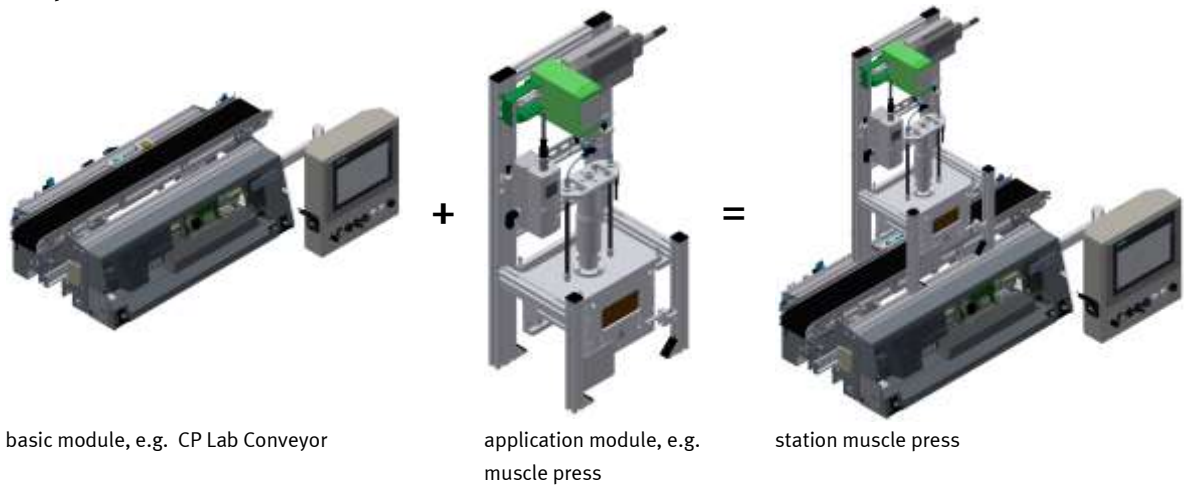

If several stations are put in a row one behind the other, this will form a production line.



Carriers are transported on the conveyors of the basic modules. And on the carriers, there are pallets with a fixed workpiece reception placed. The workpieces are placed on the workpiece reception or taken from it. Pallets can also be placed on a carrier in some stations or gripped from there.

The typical workpiece of a CP Factory/Lab System is the roughly simplified version of a mobile phone. The workpiece consists of a front cover, of a back cover, of a board and of a maximum of two fuses.

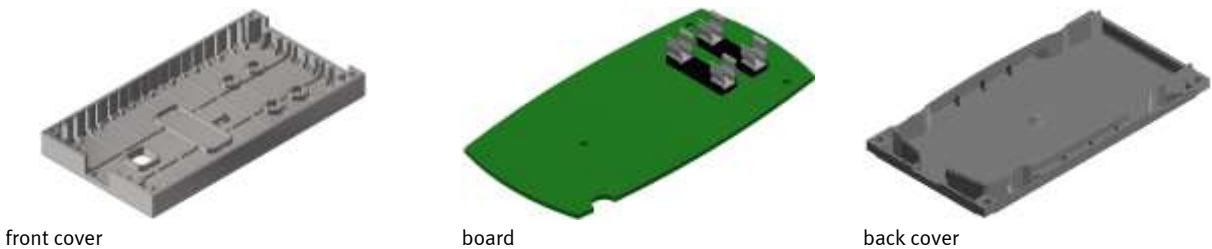

### **7.3 ASRS for pallets**

The ASRS for pallets consists of a two-lane conveyor line which is 1200 mm long. The storage application is firmly connected to the conveyor line. The conveyors are 80 mm wide. They are for transporting boards on carriers.

The carriers are equipped with a read/write ID-system. This ID-system represents an important item of the CP Factory System. The current data of the workpiece to be transported are written on the carriers. In this way, all information essential for the process is transported together with the carrier and is therefore available at every operating position.

The station has only one operating side, it is not possible to work on the backside of the ASRS for pallets.

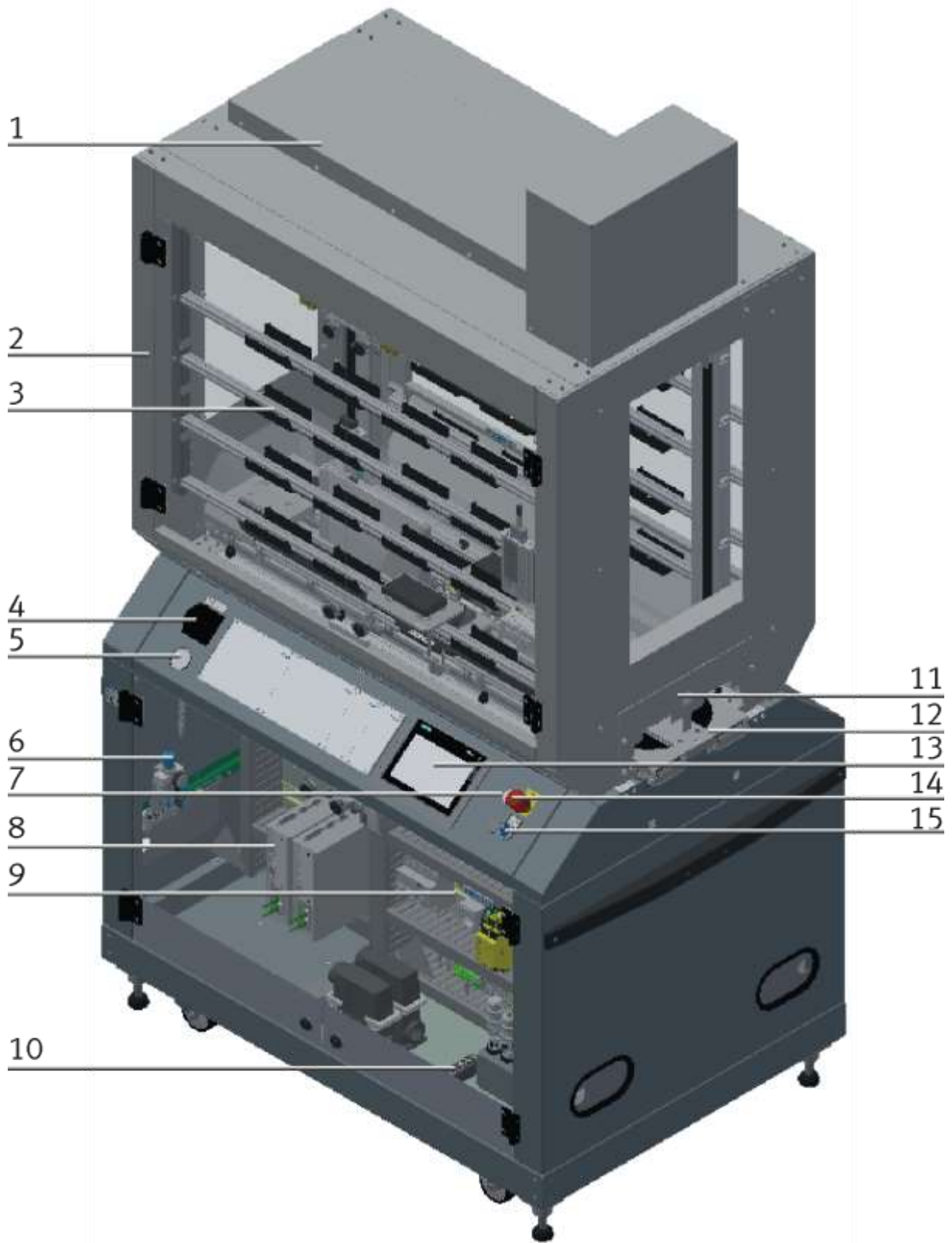

CP Factory ASRS for pallets / illustration similar

Position	Designation
1	Safety racket cover (no interaction possible)
2	Safety racket
3	Storage shelf
4	Main switch control panel
5	Manometer
6	Maintenance unit
7	Ethernet interface
8	E-board for AS/RS
9	E-Board for basic module
10	E-board for RFID interface and communication as well as energy supply
11	Interaction protection
12	Deflection / no further module attached / protective unit has to mounted Substitute guide board/further module attached / protective unit not mounted
13	HMi Touch panel
14	Emergency stop
15	Reset pushbutton

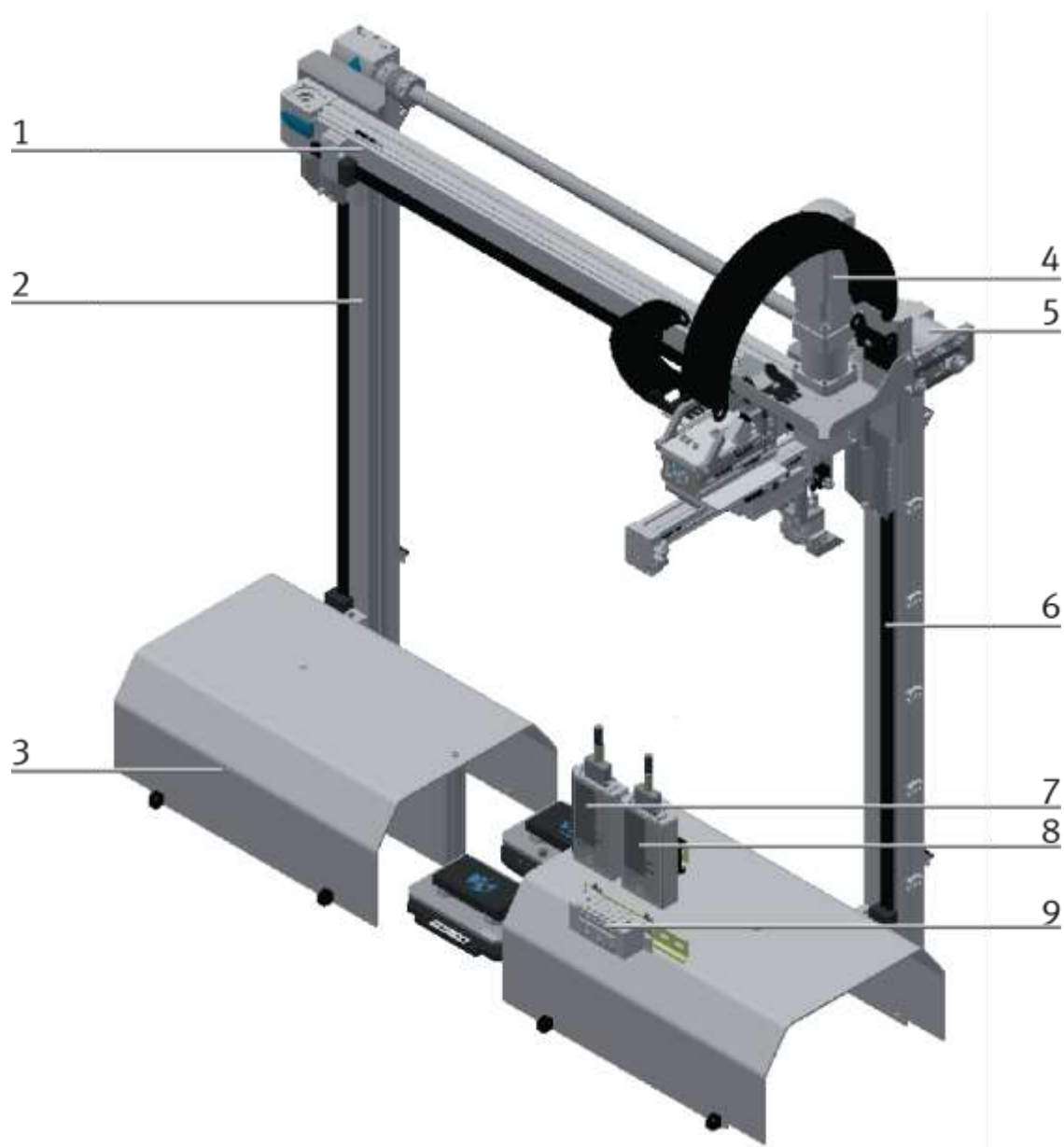

CP Factory ASRS for pallets / illustration similar

Position	Designation
1	X-Axis
2	Passive guide Z-axis
3	Protective tunnel against interaction
4	Motor X-axis
5	Motor Z-axis
6	Z-axis
7	I/O Box 2 (XD51)
8	I/O Box 1 (XD41)
9	Valve terminal



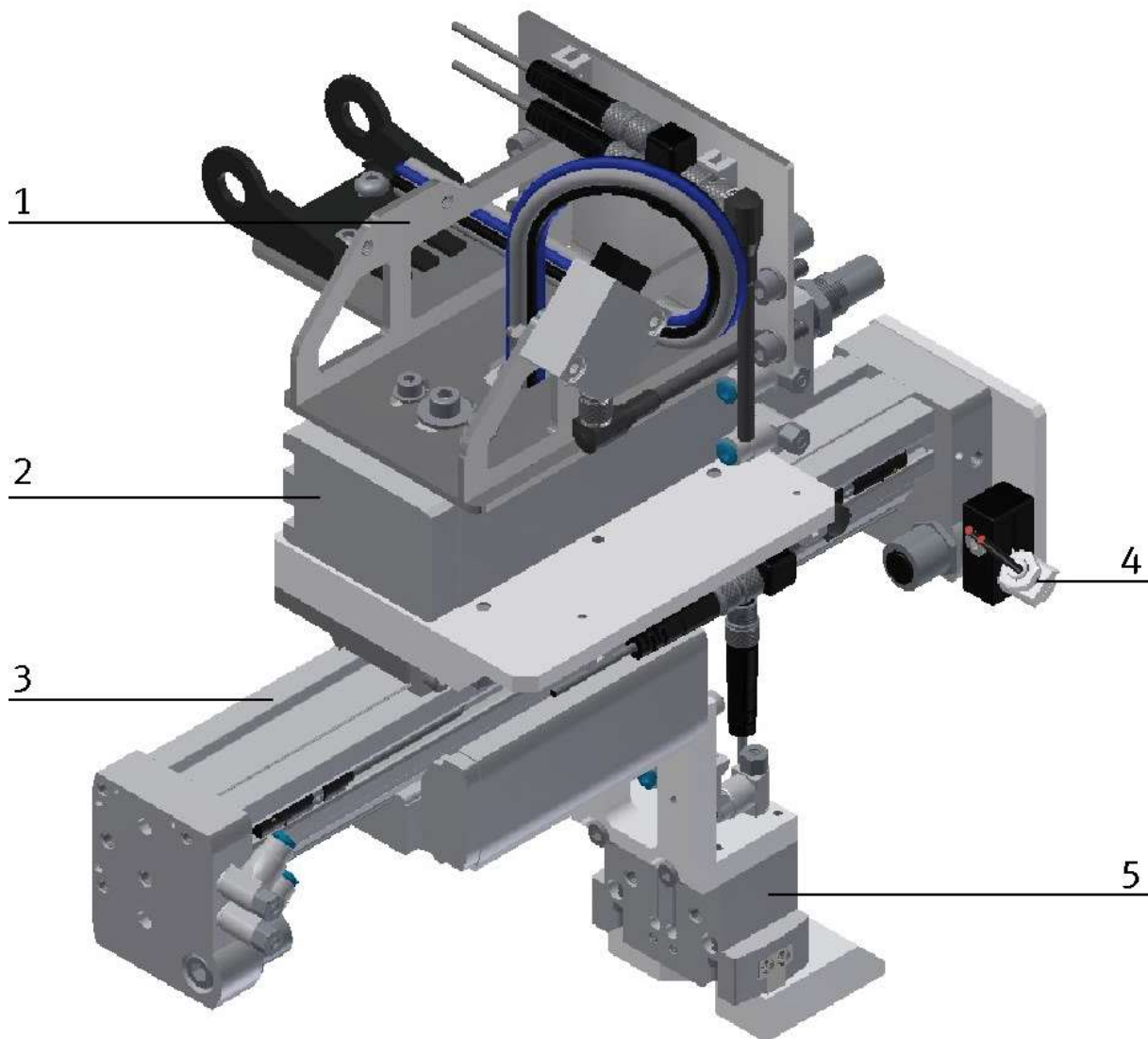

Illustration similar

Position	Designation
1	Console
2	Rotary cylinder / C-axis (563338 / DRQD-B-20-180-YSRJ-A-AL-FW)
3	Y-axis (532446 / DGC-18-140-KF-PPV-A)
4	Sensor for pallet identification
5	Gripper (HGPT-20-A-B-G1 / 560199)

### 7.4 Mechanical setup

The basic module linear has been constructed for operation from both sides, the ASRS for pallets has the same frame, but it is possible to operate only from the frontside.

The ASRS for pallets is equipped with mechanically adjustable feet. Should it be necessary to move the module to another place, it can be lowered to its rollers and thus be transported easily.

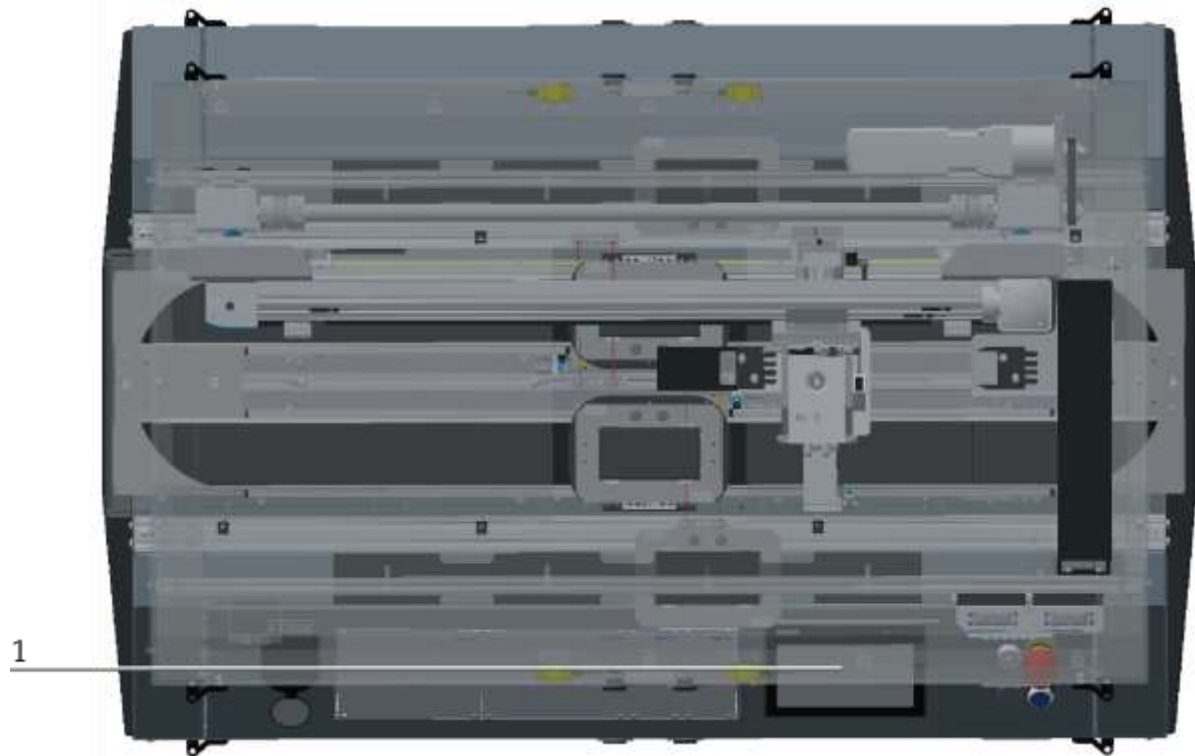

Construction of ASRS for pallets / Illustration similar

Position	Description
1	Operating side

The modules can be operated in two ways - as a single station or in a chain with further modules. When connected to a further module, it is necessary to replace the deflection at the end of the band by means of a support plate. The switch is an exception, if this is operated as a single station, it is not possible to eject or introduce workpieces via the switches.

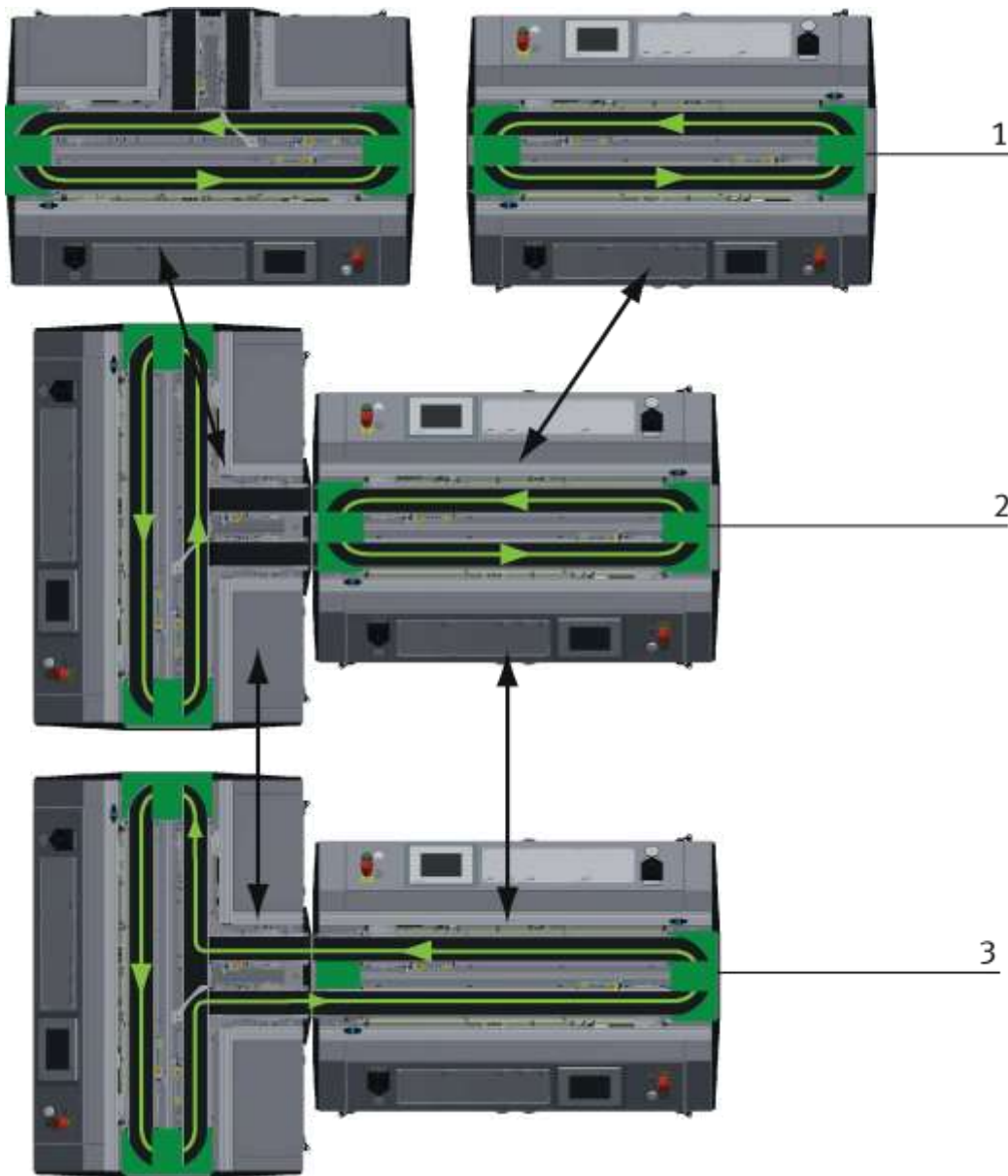

Installation Options example / illustration similar

With the pluggable tape deflections there are different possibilities to control the transport flow. Depending on this, different modules can be operated individually or in combination.

Position	Description
1	Operation as independent Basic Module /not put together
2	Operation as independent Basic Module /Basic Module put together
3	Operation connected with another Basic Module



Installation as independent basic module (example) / illustration similar

Position	Description
1+2	corner pulley – the carrier is reversed from one conveyor to the other on the basic module

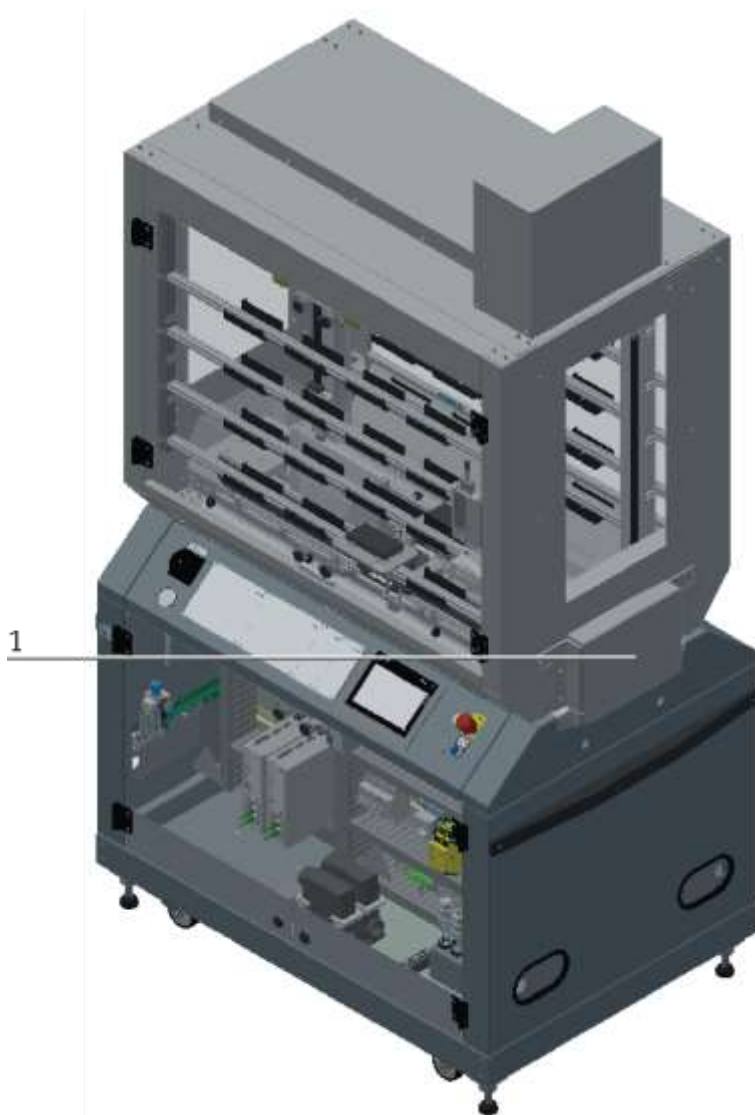

Illustration similar



### ***NOTE***

- If no further station is mounted and the workpiece carriers are not transferred to a following station, the protective bell must be mounted to prevent interference with the station. This applies to both sides of the station.



Installation in combination with another basic module (example) / illustration similar

Position	Description
1	Replacement guide board (support plate) if connected to another Basic Module – the carrier is not reversed but directed to the next module
2	corner pulley – the carrier is reversed from one conveyor to the other conveyor on the Basic Module

The corner pulley and the support plate are only pinned and can be changed easily without tools.

### 7.4.1 Operating positions

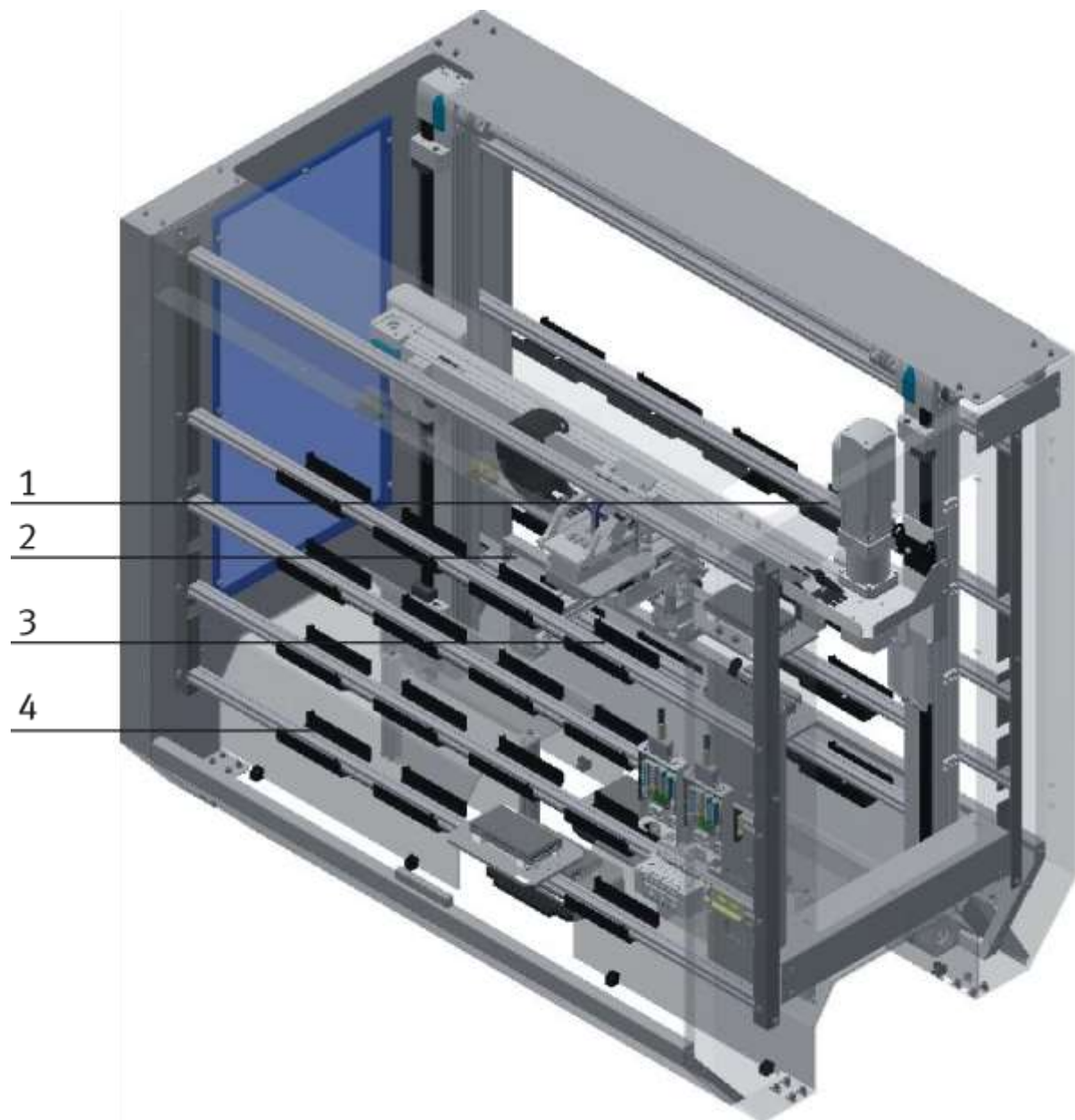

Example for storage shelf of ASRS for pallets / illustration similar

Position	Description
1	Storage shelf 32
2	Storage shelf 17
3	Storage shelf 16
4	Storage shelf 1

All further storage shelves are rising from the left to the right and from bottom to top.

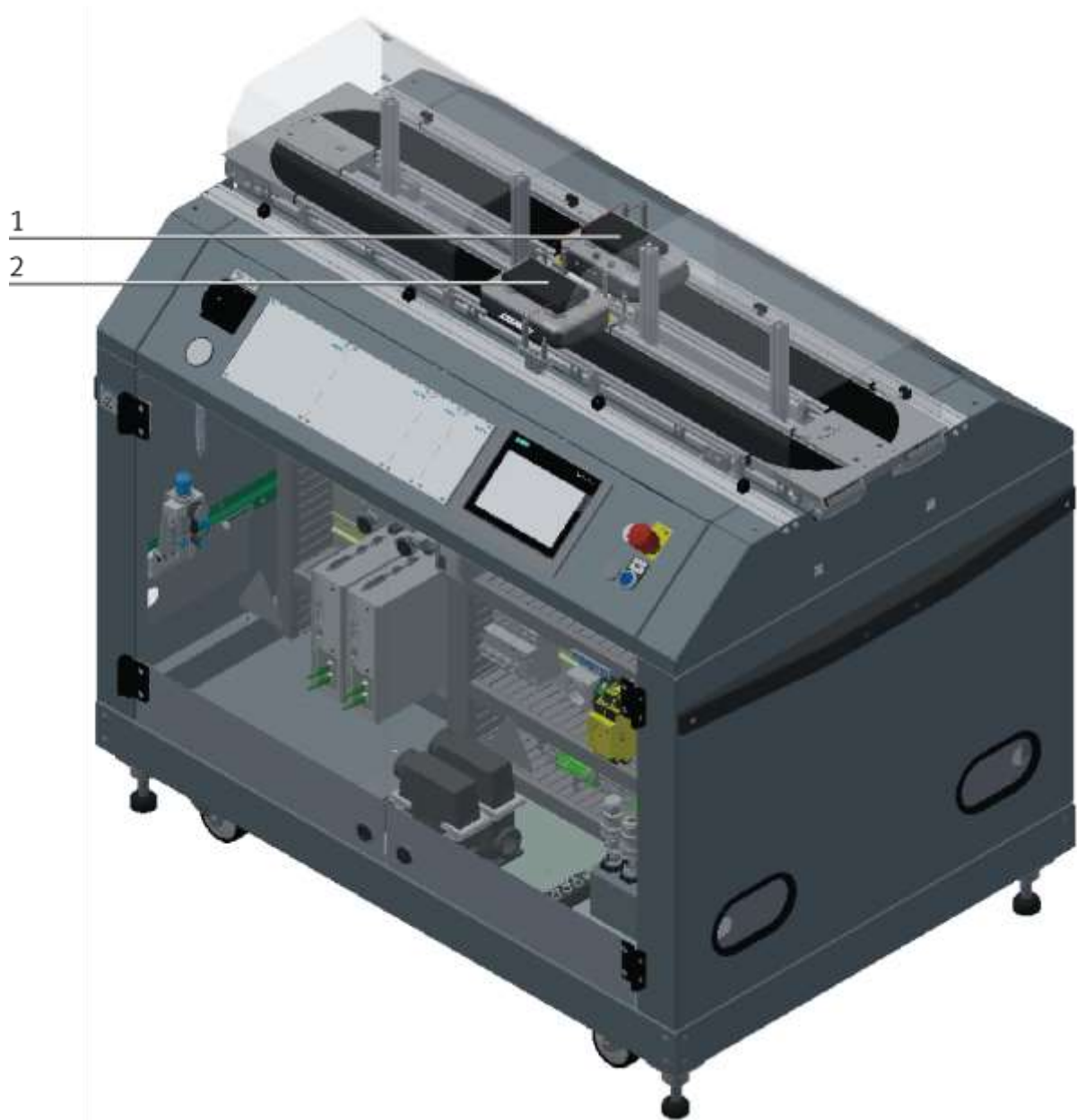

Example for operating positions on the ASRS for pallets / illustration similar

Position	Description
1	Pos 91 Loading position
2	Pos 90 Retrieval position



### 7.4.2 Supply of the ASRS for pallets

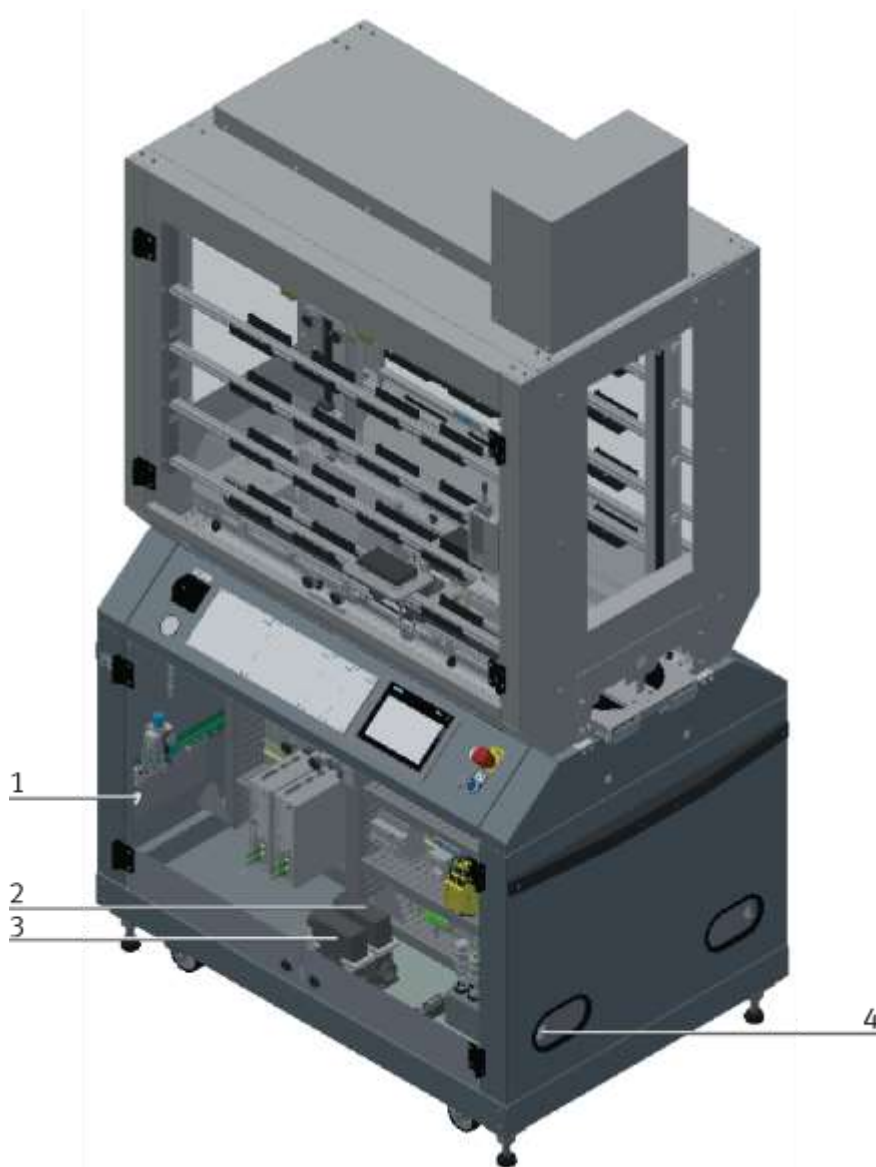

CP Factory supply / Illustration similar

Position	Description
1	Inlet port for connection tube with voltage, communication and pneumatics
2	Connection plug K2-XZ1
3	Connection plug K2-XZ2
4	Outlet port for the connection tube of a further basic module



## WARNING

- **Electric shock when reaching into the inlet/outlet openings.**
  - The inlet/outlet openings are secured against reaching in with a metal sheet.

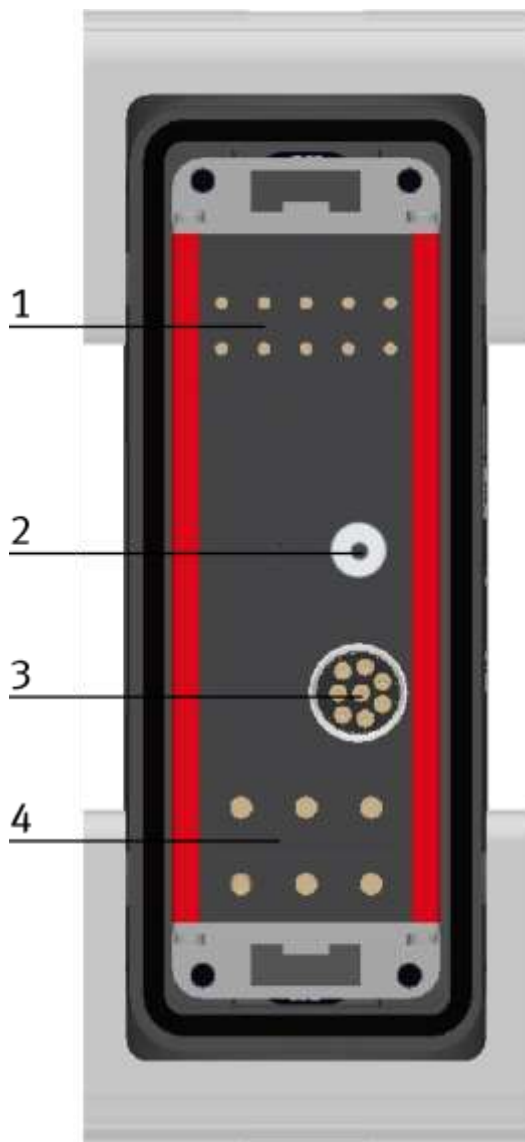

Position	Description
1	Emergency chain linking
2	Pressure
3	Network
4	400 V

### 7.5 Electrical installation

The ASRS for pallets has got an electric board (2) for the electric components of the module. This electric board has been installed in the right part of the housing. On the left side, the electric board (1) for the storage application has been inserted.

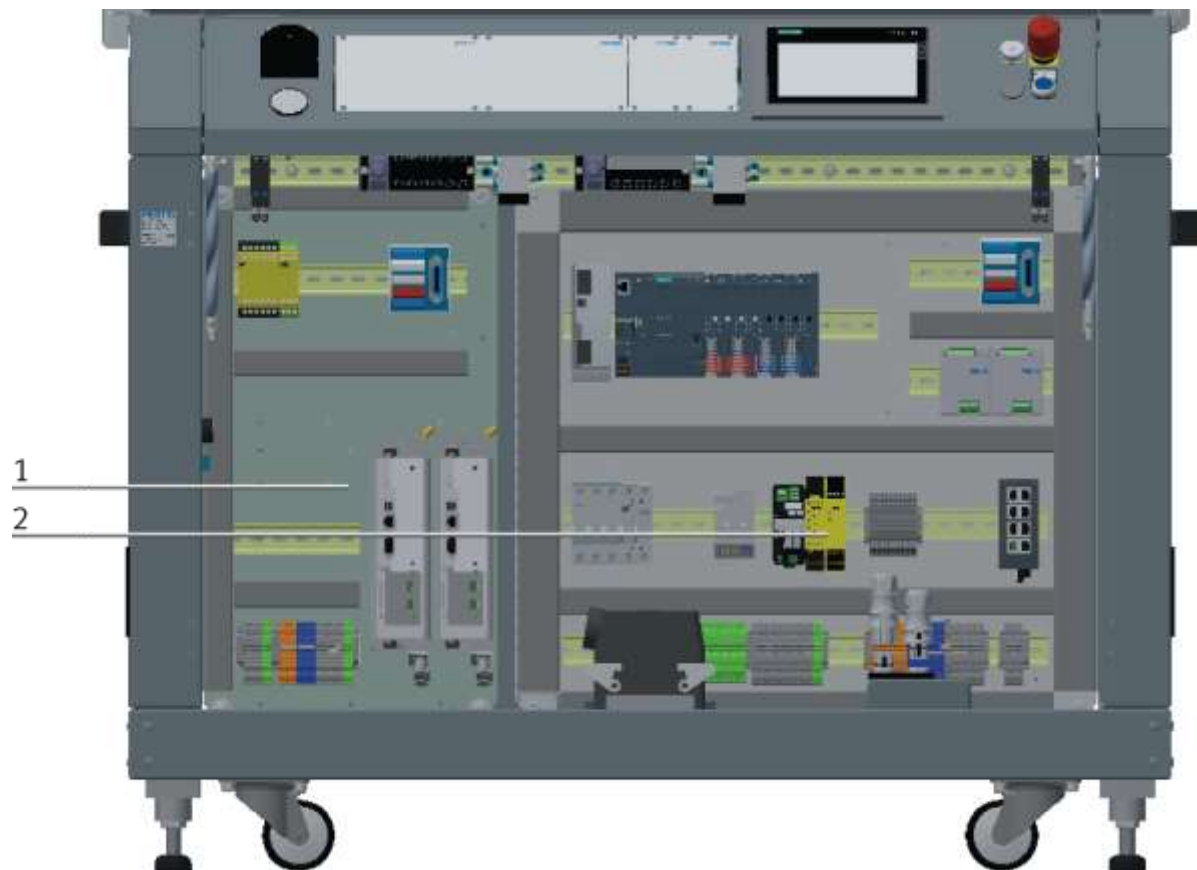

Electric boards ASRS for pallets example / illustration similar



Electric board basic module with Siemens controller / illustration similar

Position	Designation	BMK	Description / Ordernumber
1	CPU	K1-K5KF1- K1-K5KF21	Siemens ET200 SP CPU 1512 / 1516 SP F-1 P
2	Power supply unit 24 V	TB1	Festo CACN-3A-1-10 / 2247682
3	Circuit breaker	FC1	Siemens 5SY6310-7
4	Ground fault circuit interrupter (FI/LS)	FC2	Siemens 5SU1354-6KK06
5	230 V socket	K1-XJ4	709-581
6	Circuit breaker / electronic overcurrent protection devices	FC4	Mico 2.6
7	Emergency stop unit	F2-KF1	Sick UE410-GU4 / 1094339
8	Emergency stop unit	F2-KF2	Sick UE410-4RO4 / 6032676
9	Clamps	K1-XD0	
10	Clamps	K1-XD1	
11	I/O Terminal	XD15	
12	Start-up current limiter	K1-QA1	Kaleja M-MZS-4-30 / 06.05.020
13	Start-up current limiter	K1-QA2	Kaleja M-MZS-4-30 / 06.05.020
14	Clamps	K1-XD14	
15	Ethernet switch	K1-XF1	Siemens Scalance XB008 / 6GK5008-0BA00-1AB2
16	Clamps	K1-XD10	
17	Clamps	K1-XD13	

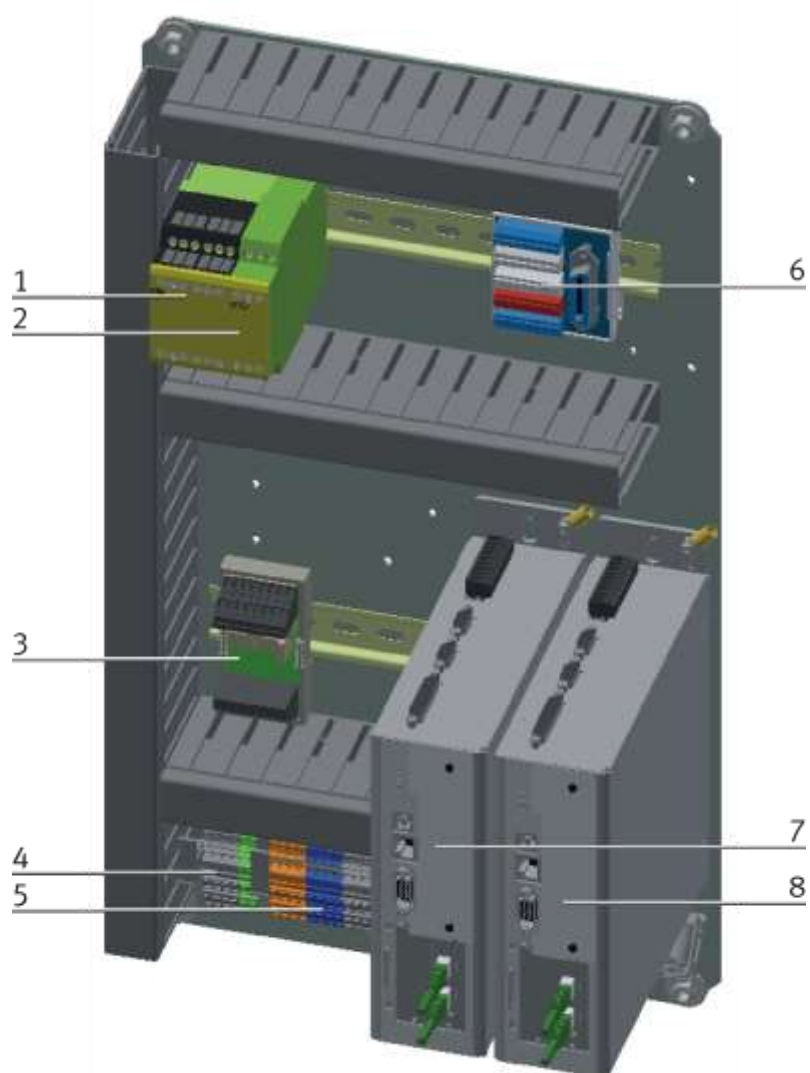

Example for electric board application ASRS / illustration similar

Position	Description	BMK	Description / Order number
1	PNOZ X8P	F2-KF2	
2	PZE X4P 24VDC	F2-KF3	
3	PSEN iX1	F2-KF4	
4	I/O Terminal	XD40	
5	CMMS AS servo controller X-axis	K6-KF1	550041 / CMMP-AS-C2-3A
6	CMMS AS servo controller Z-axis	K6-KF2	550041 / CMMP-AS-C2-3A
7	Clamps	XD1	
8	Clamps	XD10	

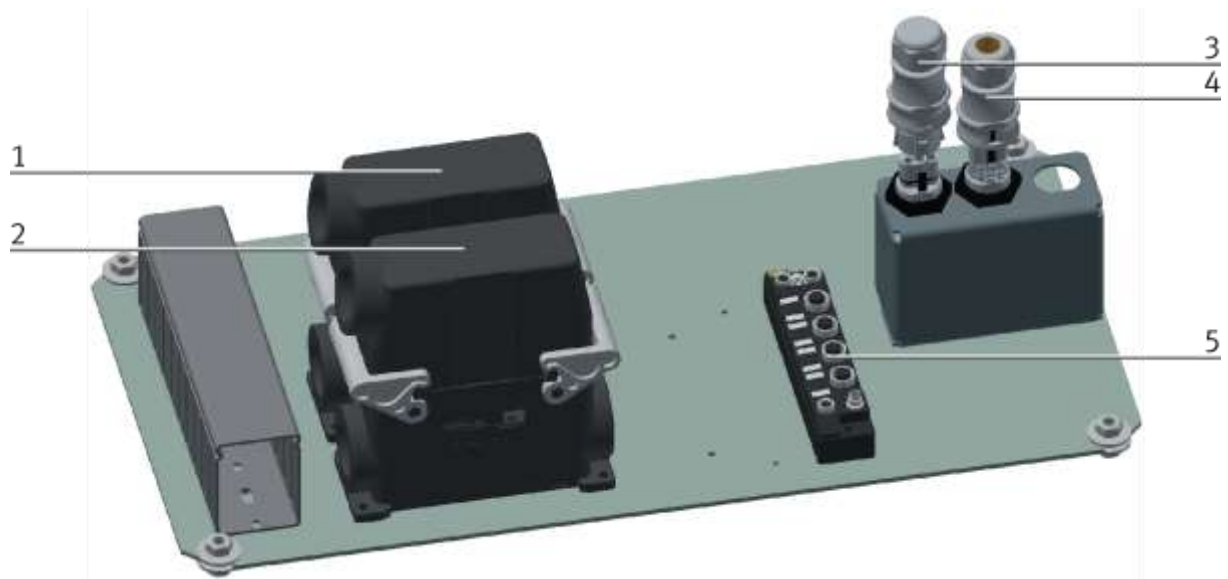

E-board front side / illustration similar

Position	Description	BMK	Description / order number
1	Supply plug feed in	K2-XZ1	
2	Supply plug forwarding	K2-XZ2	
3	Supply plug	K2-XJ1	
4	Supply plug	K2-XJ2	
5	RFID	K2-KF80	

### 7.5.1 Emergency-stop structure

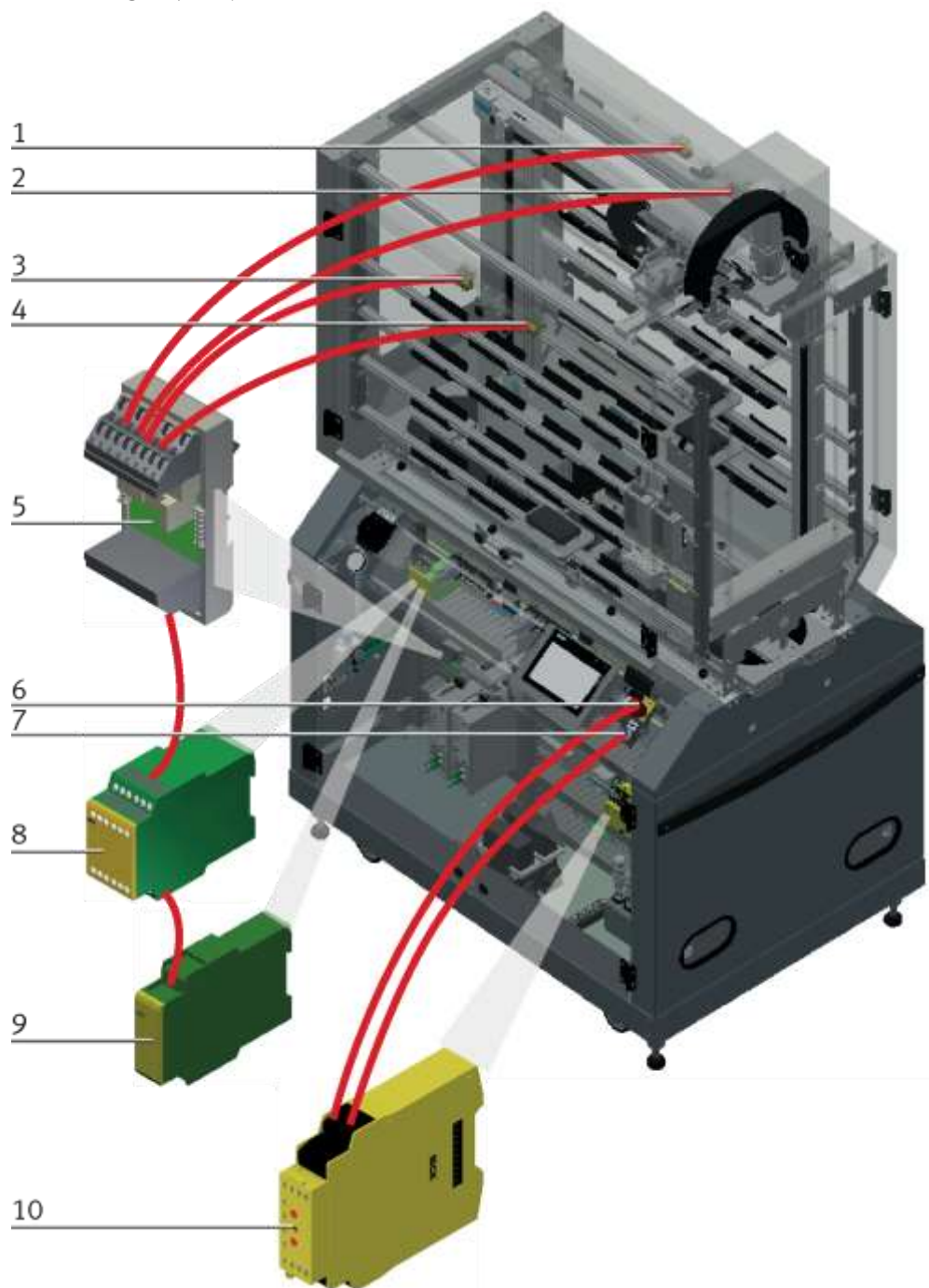

Structure of the emergency-stop system / illustration similar

#### Servocontroller behavior

The emergency stop acts on the Sick relay (10) and thus also on the controller enable of the servocontrollers, among others.

Devices (8) and (9) are only responsible for the safety gate function, they only switch off the servo drives (STO input of the servo controller).



Position	Name
1	Guard door 3 / F2-FQ3
2	Guard door 4 / F2-FQ4
3	Guard door 1 / F2-FQ1
4	Guard door 2 / F2-FQ2
5	PSEN iX1 / F2-KF4
6	Emergency-stop pushbutton F2-FQ1 / to emergency stop board X4:1: X4:3; X4:5; X4:7
7	Reset Pushbutton F2-SF1 / to PNOZ S33+S34; indicator light terminal strip 24VNA/OV+
8	Safety door controller unit PNOZ X8P / F2-KF2
9	Safety door controller unit PZE X4P 24 VDC / F2-KF3
10	Emergency stop relay / F2-KF1

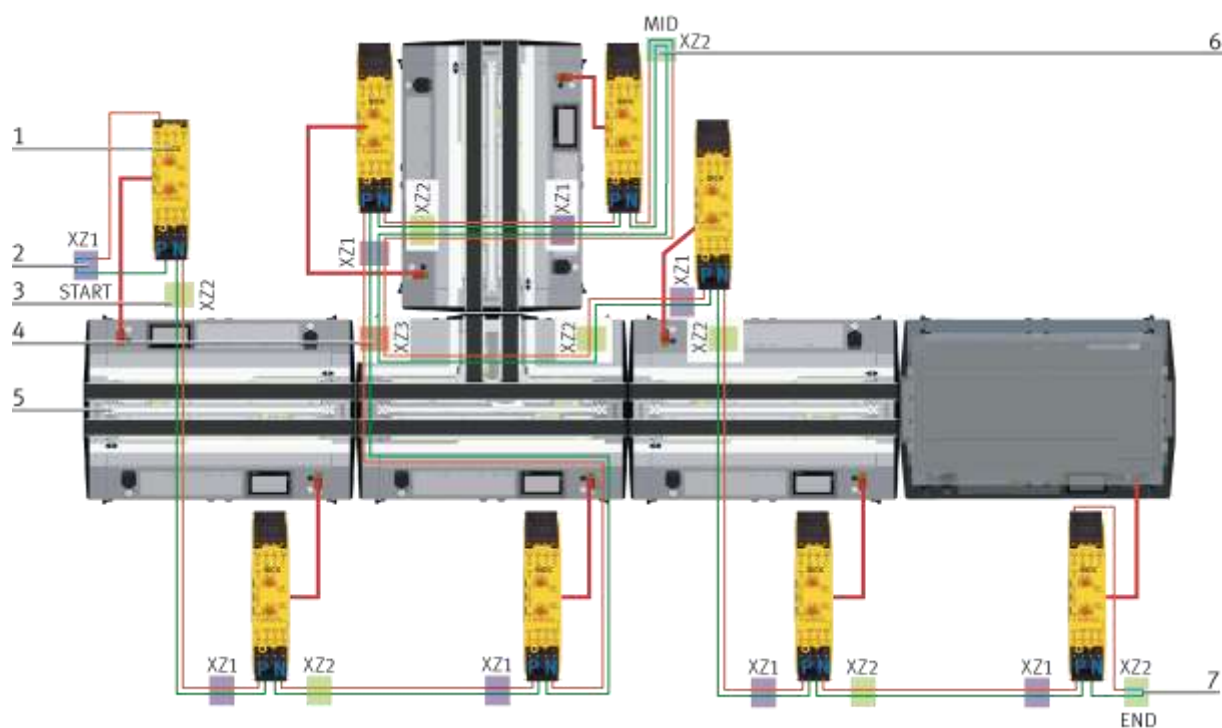

Example of the structure of the emergency stop system / Illustration similar

Pos	Description
1	Emergency stop Sick FlexiClassic UE410-GU Marking P (IP/OP = in/out Previous) Marking N (IN/ON = in/out Next) Sick FlexiClassic UE410-4RO4 for emergency stop chaining is not shown graphically
2	Incoming connector XZ1 / START, first emergency stop on main line (bridge required)
3	Outgoing connector XZ2
4	Outgoing plug connection XZ3 (only possible at turnout)
5	Basic module linear
6	Outgoing connector XZ2 / MID, last emergency stop on branch line (bridge required)
7	Outgoing connector XZ2 / END, last emergency stop on main line (bridge required)

The emergency stop system affects the whole line, so if an emergency stop is pressed, all stations in the line stop.

### 7.5.2 Emergency stop configuration

Each system must have 1 START and 1 END connector, all connectors in between are MID connectors. The direction always goes from the power supply along the output X2.

If the configuration of the emergency stop system is changed, it is necessary to reprogram the emergency stop relays. This is necessary for the initial commissioning or if an emergency stop cable is reconnected. In this case proceed as follows

1. Switch off the power supply (terminals A1, A2) on all main modules.
2. use a screwdriver to set the switch positions on the rotary switches to 1 on all modules in the system. (is always 1 in this system, may be different for other purposes).
3. while holding down the ENTER key of the UE410-GU main module, switch on the power supply of all modules.
4. when the ERR display starts flashing, release the ENTER key within 3 seconds.
5. the selected operating mode is stored zero-voltage safe and active.

### 7.5.3 Acknowledge emergency stop after restart

1. emergency stop is pressed, station is switched off
2. switch on main switch (wait 5 sec.)
3. RESET button flashes quickly
4. pull out emergency stop to unlock
5. RESET button flashes slowly
6. press RESET button - emergency stop is acknowledged
7. lamp RESET button goes off
8. acknowledge HMI

This procedure must be carried out at all stations!

### 7.5.4 Acknowledging emergency stop after emergency stop

1. emergency stop is pressed at a station
2. the RESET button on the station with emergency stop flashes quickly
3. the RESET button on all other stations is illuminated
4. pull out the pressed emergency stop to unlock it
5. the RESET button flashes slowly
6. press RESET button - emergency stop is acknowledged
7. the RESET button lamp goes out
8. acknowledge HMI at all stations

### 7.5.5 Gripping protection tunnel

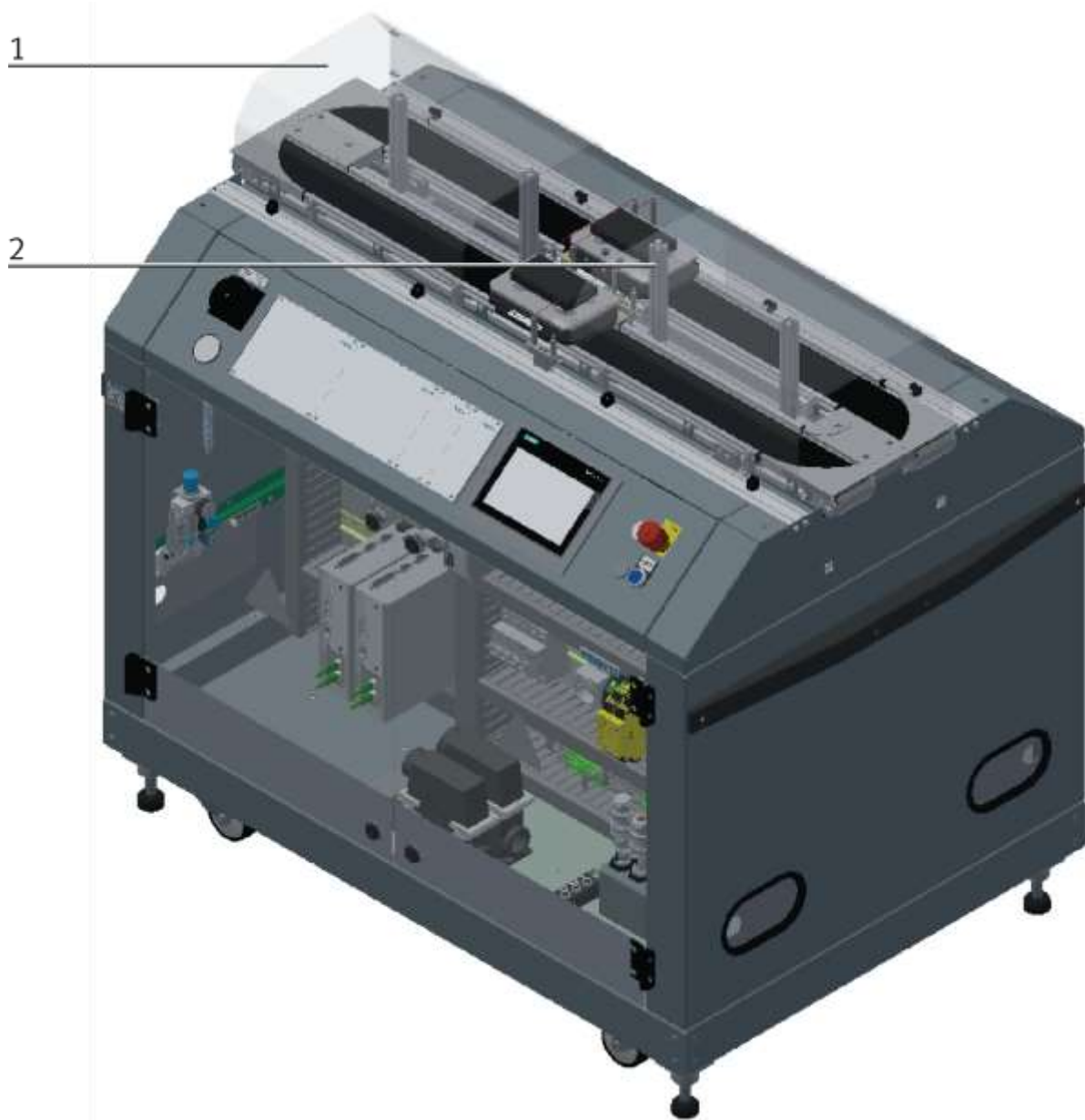
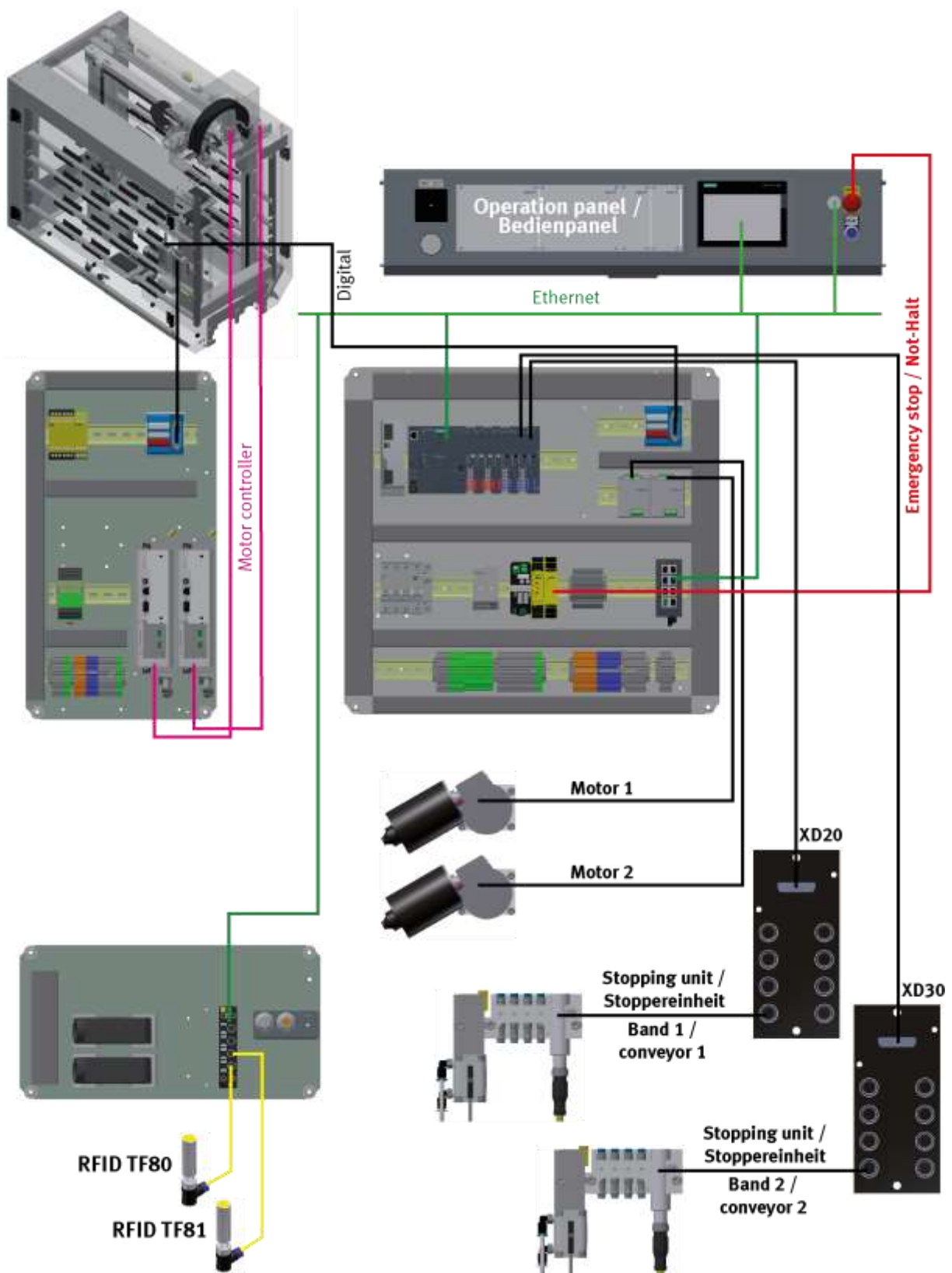

Illustration similar

Position	Description
1+2	Gripping protection tunnel – to avoid gripping in danger area

### 7.5.6 Electrical connection



Electrical connection / illustration similar

### Connection with sys link plugs

The storage application is connected to the E board by I/O connections.

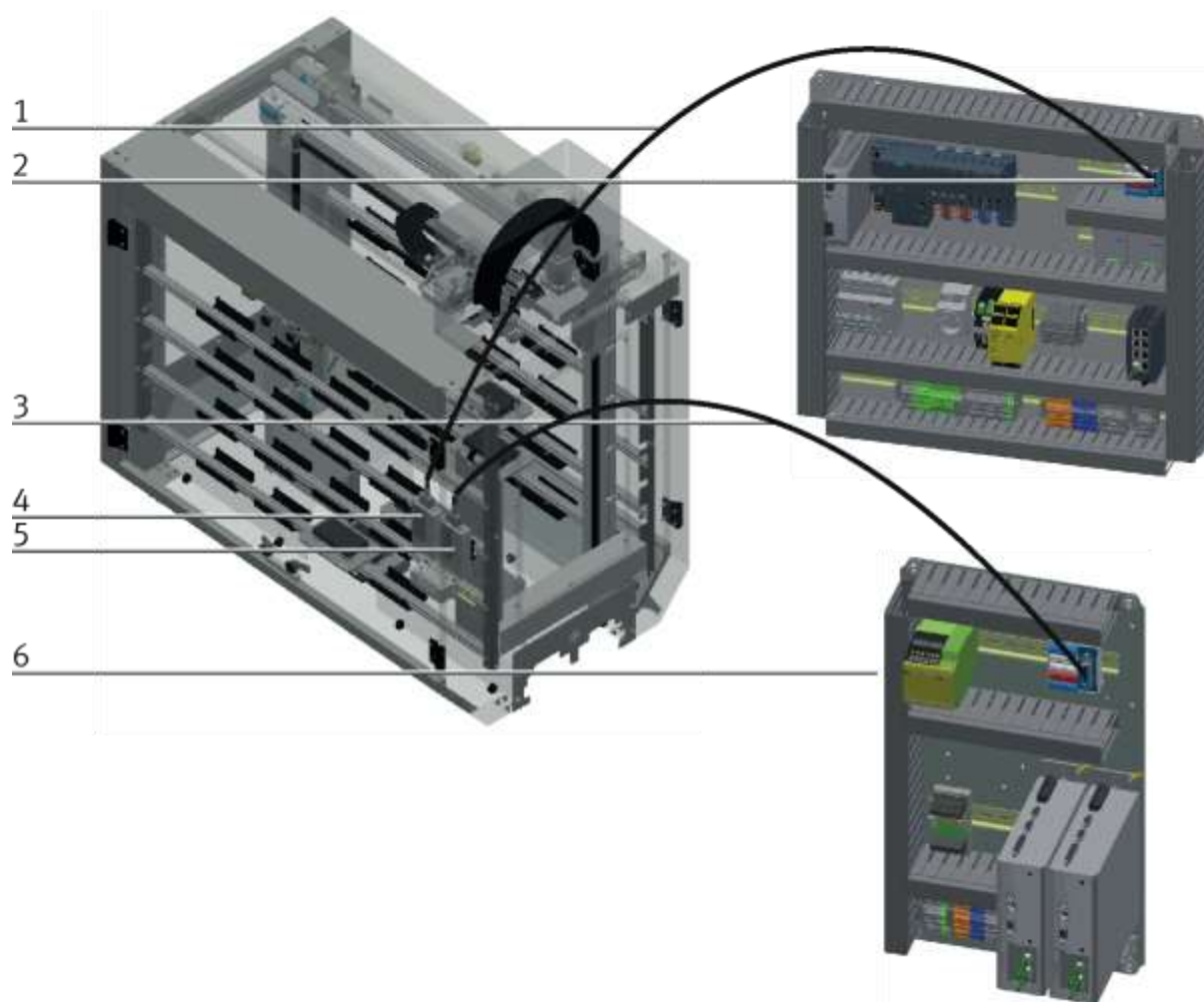

Electrical connection by I/O / illustration similar

Position	Description
1	SysLink cable WXMB2
2	I/O terminal XD50
3	SysLink cable WXMA2
4	I/O Box 2 (XD51)
5	I/O Box 1 (XD41)
6	I/O terminal XD40

The motors of the storage application are connected to the E board by special motor cables. We will take the Z-axis as an example.

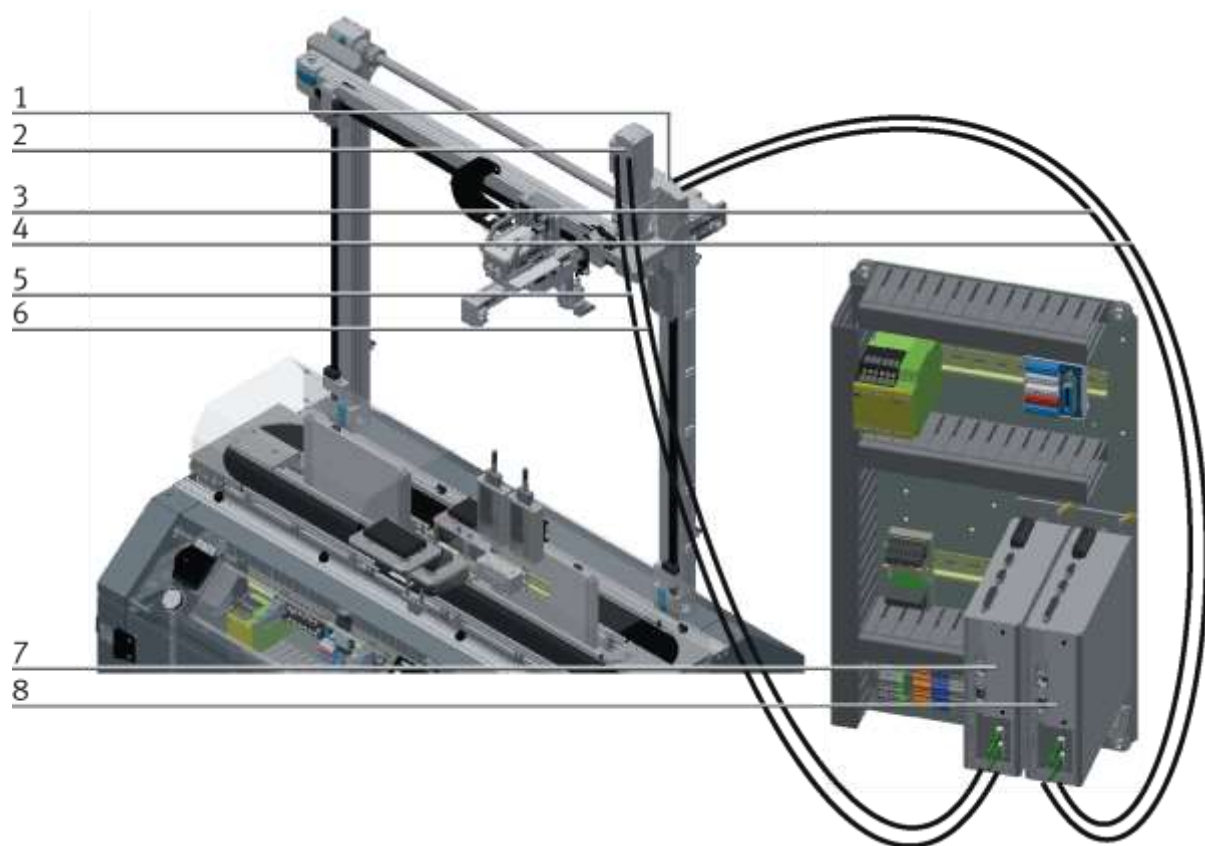

Electrical connection motors / illustration similar

Position	Description
1	Motor Z-axis / K6-MA2
2	Motor X-axis / K6-MA1
3	Motor supply cable Z-axis / K6-MA2-MW1-/ NEBM-M23G6-E-5-N-LE7
4	Control cable motor Z-axis / K6-MA2-EW2
5	Motor supply cable X-axis / K6-MA1-MW1-/ NEBM-M23G6-E-5-N-LE7
6	Control cable motor X-axis / K6-MA1-EW2
7	Servo controller X-axis / CMMP-AS-C2-3A-M3 / K6-KF1
8	Servo controller Z-axis / CMMP-AS-C2-3A-M3 / K6-KF2

## **7.6 Commissioning**

The ASRS for pallets has got several components which have to be attached when starting up. The procedure will be described on the following pages.

### **7.6.1 Pneumatic commissioning**

The mechanic mounting must be finished and completed. At first you have to connect the ASRS to the pneumatic system of the room. The corresponding service unit has to be provided by the customer and should be placed right next to it. The quick coupling plug has got a nominal size of 5 mm. If the local system has got a nominal size of 7.9 mm, it is possible to exchange the quick coupling plug of the service unit for a bigger one (adapter 1/8 to 1/4 necessary).

Now the station can be supplied by 6 Bar and the pneumatic commissioning is completed.

### **7.6.2 Electrical commissioning**

Now the ASRS for pallets has to be supplied with electric voltage (400 V). The voltage has to be provided by the customer. Professional installation must be guaranteed as well.

## **7.7 Visual inspection**

The visual inspection must be carried out before each start-up!

Before starting the station, check:

- the electrical connections
- the correct fit and the condition of the compressed air connections
- the mechanical components for visible defects  
(Cracks, loose connections, etc.)
- the emergency stop devices are working

Eliminate any damage found before starting the station!



## 7.8 Adjusting the sensors

### 7.8.1 Proximity switch (stopper Identsensor)

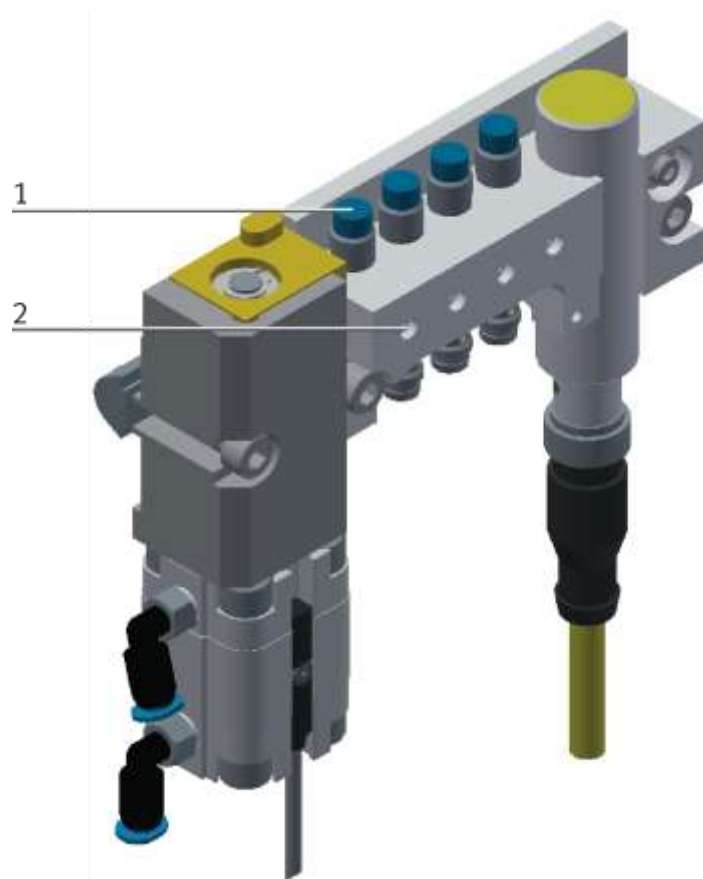

Illustration similar

Position	Description
1	Sensor stopper identify sensor / 150395 (SIEN-M8NB-PS-S-L) 1 position (BG21/BG31/BG41) 2 position (BG22/BG32/BG42) 3 position (BG23/BG33/BG43) 4 position (BG24/BG34/BG44)
2	Screw to clamp the sensor

The proximity switches are used for controlling the carrier.

### **Requirements**

- Stopper unit is attached to the conveyor.
- Electrical connection of the proximity switches is set up.
- Power supply is available.

### **Procedure**

1. The stopper is in upper position, a carrier is stopped at the stopper.
2. Shift the switch as long as the switching status display (LED) appears.
3. Shift the proximity switch into the same direction by a few millimetres as long as the switching status display disappears.
4. Shift the proximity switch halfway between the start-up and end position.
5. Tighten the locking screw of the proximity switch with an Allen key SW 1,3.
6. Check the position of the proximity switch by repeated removing the carrier.

### **Documents**

- Data sheets / operating instructions  
Proximity Switch 150395 (SIEN-M8NB-PS-S-L)

### 7.8.2 Proximity switch (stopper cylinder)

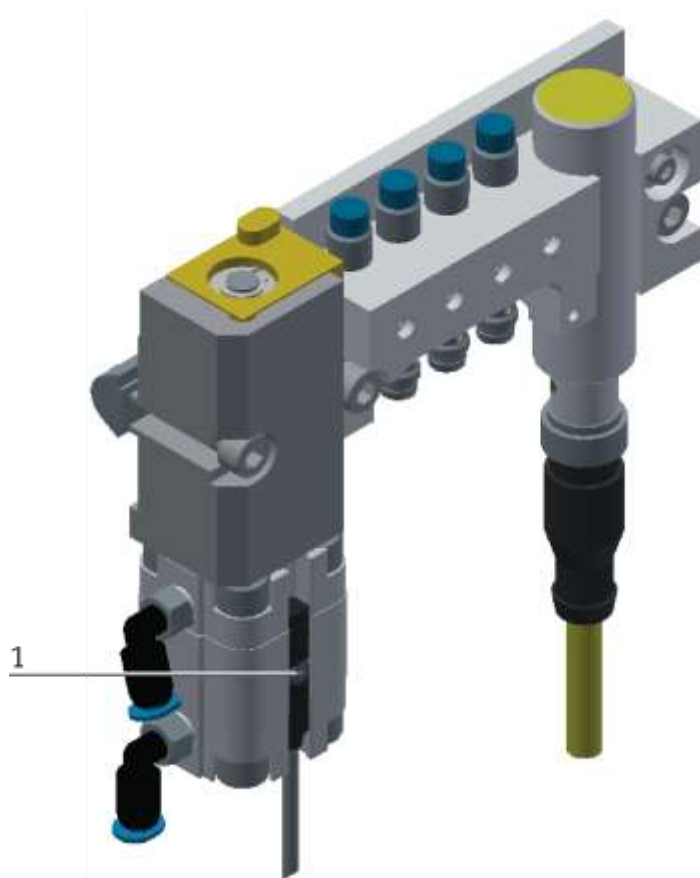

Illustration similar

Position	Description
1	Sensor stopper down/ 574334 (SMT-8M-A-PS-24V-E-0,3-M8D) (BG20) / (BG30) / (BG30) / (BG40)

The proximity switches are used for controlling the end position of the cylinder for the stopper. The proximity switches react to a permanent magnet on the piston of the cylinder.

### **Requirements**

- Cylinder stopper is attached to the conveyor.
- Pneumatic port of the cylinder is set up.
- Compressed air supply is switched on.
- Electrical connection of the proximity switches is set up.
- Power supply is available.

### **Procedure**

1. The cylinder is in its end position to be queried.
2. Shift the proximity switch as long as the switching status display (LED) appears.
3. Shift the proximity switch into the same direction by a few millimetres as long as the switching status display disappears.
4. Shift the proximity switch halfway between the start-up and end position.
5. Tighten the locking screw of the proximity switch with an Allen key SW 1,3.
6. Check the position of the proximity switch by repeated test runs of the cylinder.

### **Documents**

- Data sheets / operating instructions  
Proximity Switch 574334 (SMT-8M-A-PS-24V-E-0,3-M8D)

### 7.8.3 Proximity switch (Z-axis cylinder)

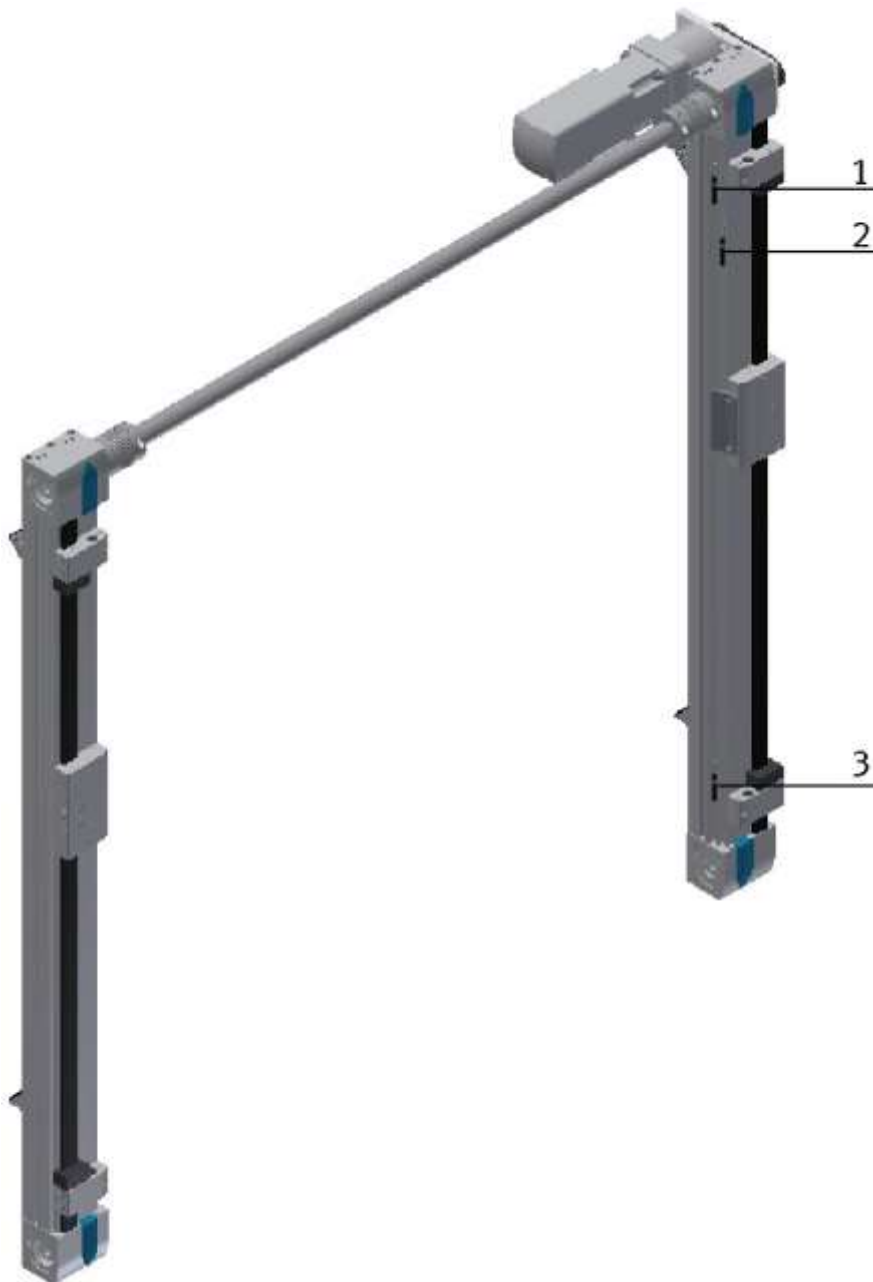

Illustration similar

Position	Description
1	Sensor Z-axis top end position (BG44) / 551391 (SIES-8M-PO-24V-K-7,5-OE)
2	Sensor Z-axis reference position (BG45) / 551386 (SIES-8M-PS-24V-K-7,5-OE)
3	Sensor Z-axis bottom end position (BG43) / 551391 (SIES-8M-PO-24V-K-7,5-OE)

The proximity switches are used for controlling the end position of the cylinder for the Z-axis. The proximity switches react to a permanent magnet on the piston of the cylinder.

### **Requirements**

- Cylinder Z-axis is attached to Y-axis and to swivel/gripper unit.
- Pneumatic port of the cylinder is set up.
- Compressed air supply is switched on.
- Electrical connection of the proximity switches is set up.
- Power supply is available.

### **Procedure**

1. The cylinder is in its end position to be queried.
2. Shift the proximity switch as long as the switching status display (LED) appears.
3. Shift the proximity switch into the same direction by a few millimeters as long as the switching status display disappears.
4. Shift the proximity switch halfway between the start-up and end position.
5. Tighten the locking screw of the proximity switch with an Allen key SW 1,3.
6. Check the position of the proximity switch by repeated test runs of the cylinder.

### **Documents**

- Data sheets / operating instructions  
Proximity Switch SIES -8M (551391)

### 7.8.4 Proximity switch (cylinder X-axis)



Illustration similar

Position	Description
1	Sensor X-axis left end position (BG40) / 551391 (SIES-8M-PS-24V-K-7,5-OE)
2	Sensor X-axis reference position (BG42) / 551386 (SIES-8M-PS-24V-K-7,5-OE)
3	Sensor X-axis right end position (BG41) / 551391 (SIES-8M-PS-24V-K-7,5-OE)

The proximity switches are used for controlling the end position of the cylinder for the X-axis. The proximity switches react to a permanent magnet on the piston of the cylinder.

### **Requirements**

- Cylinder X-axis is attached to the swivel/gripper unit.
- Pneumatic port of the cylinder is set up.
- Compressed air supply is switched on.
- Electrical connection of the proximity switches is set up.
- Power supply is available.

### **Procedure**

1. The cylinder is in its end position to be queried.
2. Shift the proximity switch as long as the switching status display (LED) appears.
3. Shift the proximity switch into the same direction by a few millimeters as long as the switching status display disappears.
4. Shift the proximity switch halfway between the start-up and end position.
5. Tighten the locking screw of the proximity switch with an Allen key SW 1,3.
6. Check the position of the proximity switch by repeated test runs of the cylinder.

### **Documents**

- Data sheets / Operating instructions  
Proximity switch SIES -8M (551386)



### 7.8.5 Proximity switch (Rotary cylinder C-axis)

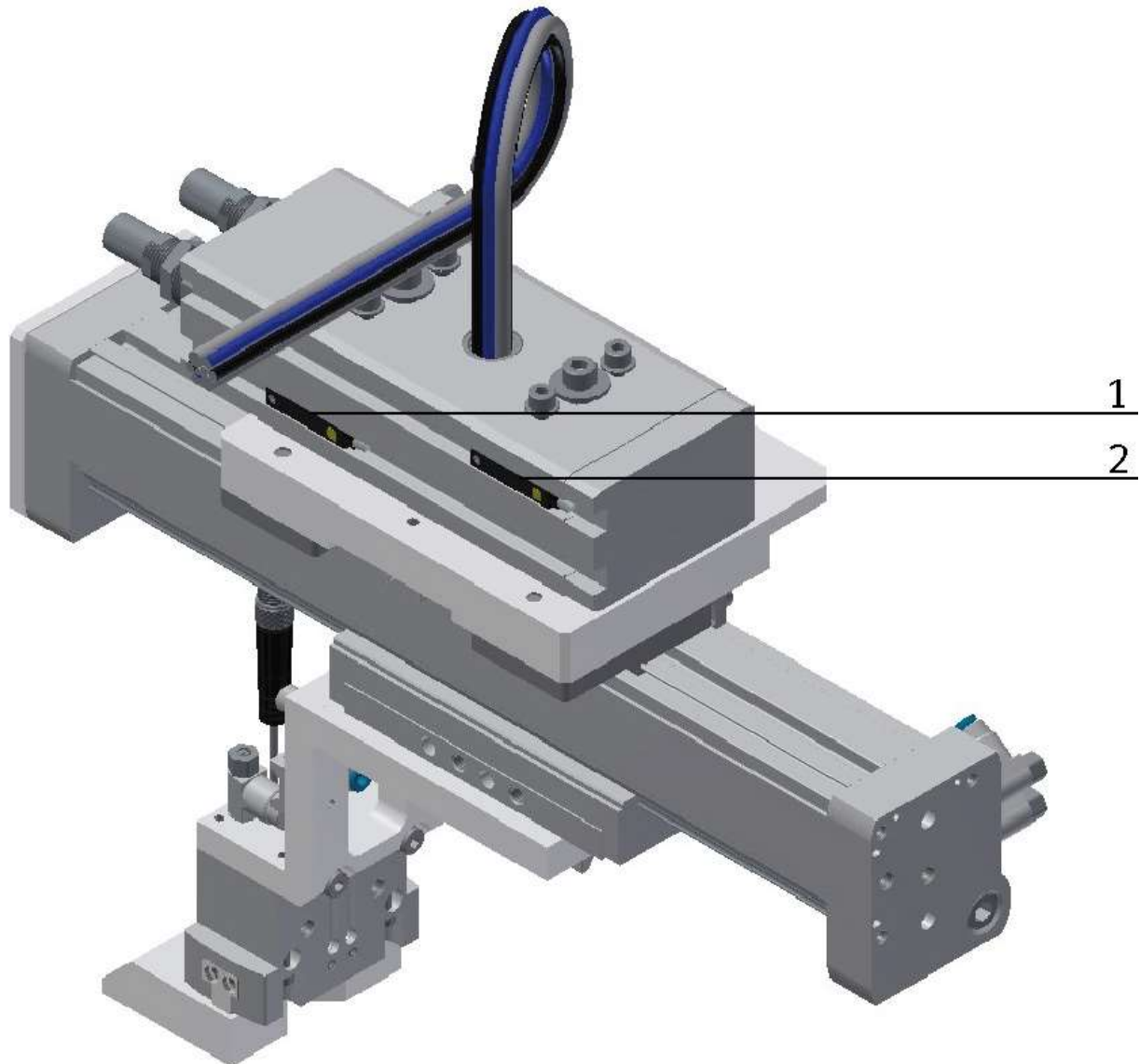

Illustration similar

Position	Description
1	Sensor C-axis turning gripper 0° (BG50) / 150857 (SME-8-S-LED-24)
2	Sensor C-axis turning gripper 180° (BG51) / 150857 (SME-8-S-LED-24)

The proximity switches are used for controlling the end position of the rotary cylinder for the C-axis. The proximity switches react to a permanent magnet on the piston of the cylinder.

### **Requirements**

- Rotary cylinder C-axis is attached to gripper unit.
- Pneumatic port of the cylinder is set up.
- Compressed air supply is switched on.
- Electric connection of the proximity switches is set up.
- Power supply is available.

### **Procedure**

1. The cylinder is in its end position to be queried.
2. Shift the proximity switch as long as the switching status display (LED) appears.
3. Shift the proximity switch into the same direction by a few millimeters as long as the switching status display disappears.
4. Shift the proximity switch halfway between the start-up and end position.
5. Tighten the locking screw of the proximity switch with an Allen key SW 1,3.
6. Check the position of the proximity switch by repeated test runs of the cylinder.

### **Documents**

- Data sheets / Operating instructions  
Proximity switch SME -8 (150857)

### 7.8.6 Proximity switch (cylinder Y-axis)

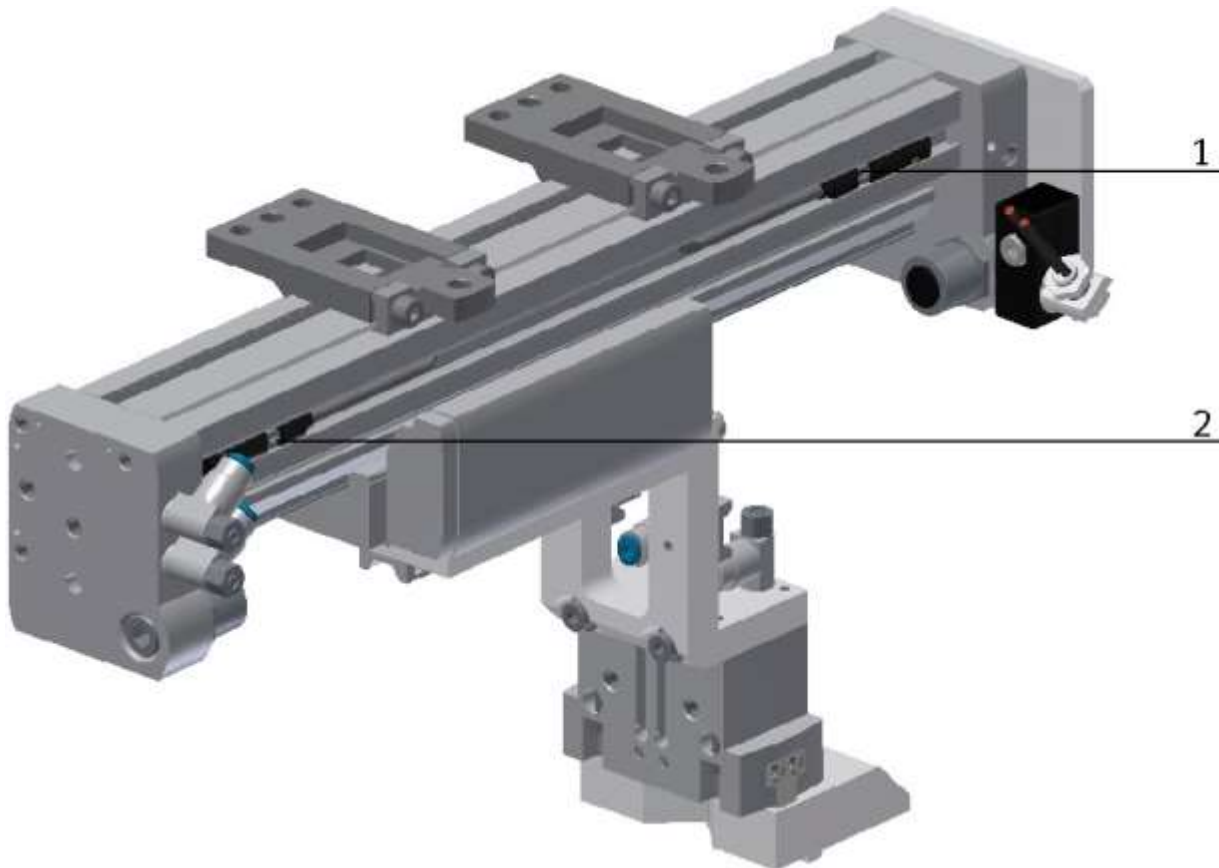

Illustration similar

Position	Description
1	Sensor Y-axis pos.2 front (BG46) / 543866 (SMT-8M-PS-24V-K-0,3-M8D)
2	Sensor Y-axis pos.1 rear (BG47) / 543866 (SMT-8M-PS-24V-K-0,3-M8D)

The proximity switches are used for controlling the end position of the Y-axis. The proximity switches react to a permanent magnet on the piston of the cylinder.

### **Requirements**

- Cylinder Z-axis is attached to gripper unit.
- Pneumatic port of the cylinder is set up.
- Compressed air supply is switched on.
- Electric connection of the proximity switches is set up.
- Power supply is available.

### **Procedure**

1. The cylinder is in its end position to be queried.
2. Shift the proximity switch as long as the switching status display (LED) appears.
3. Shift the proximity switch into the same direction by a few millimeters as long as the switching status display disappears.
4. Shift the proximity switch halfway between the start-up and end position.
5. Tighten the locking screw of the proximity switch with an Allen key SW 1,3.
6. Check the position of the proximity switch by repeated test runs of the cylinder.

### **Documents**

- Data sheets / Operating instructions  
Proximity switch 543866 (SMT-8M)

### 7.8.7 Proximity switch (gripper)

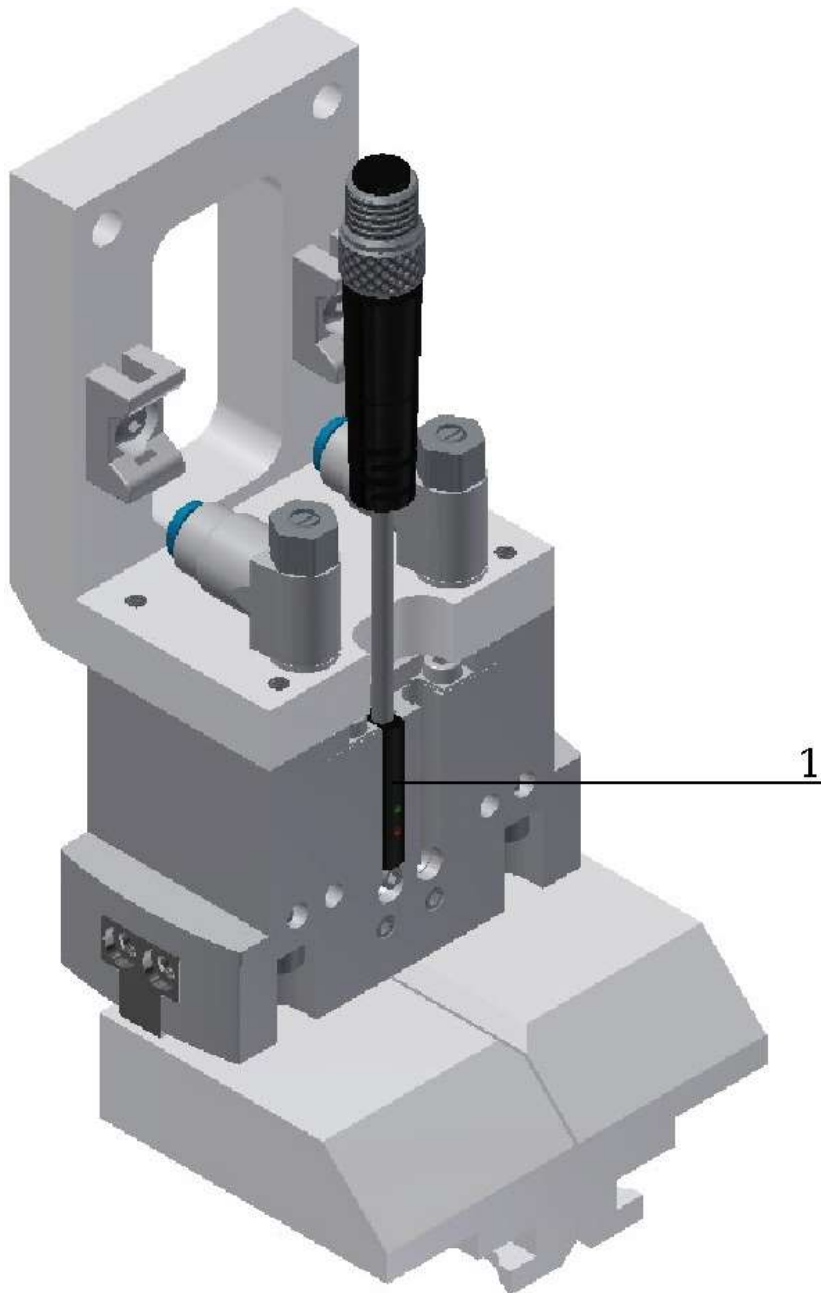

Illustration similar

Pos	Description
1	Sensor gripper open (BG52) / 525914 (SME-10F-DS-24V-K0,3L-M8D)

The proximity switches are used for controlling the end position of the gripper. The proximity switches react to a permanent magnet on the piston of the cylinder.

### **Requirements**

- Gripper is mounted.
- Pneumatic port of the gripper is set up.
- Compressed air supply is switched on.
- Electrical connection of the proximity switch is set up.
- Power supply unit is switched on.

### **Procedure**

1. The cylinder is in its end position to be queried.
2. Shift the proximity switch as long as the switching status display (LED) appears.
3. Shift the proximity switch into the same direction by a few millimeters as long as the switching status display disappears.
4. Shift the proximity switch halfway between the start-up and end position.
5. Tighten the locking screw of the proximity switch with an Allen key SW 1,3.
6. Check the position of the proximity switch by repeated test runs of the cylinder.

### **Documents**

- Data sheets / Operating instructions  
Proximity switch 525914 (SME-10F)

### 7.8.8 Through-beam sensor (Shelf detection)

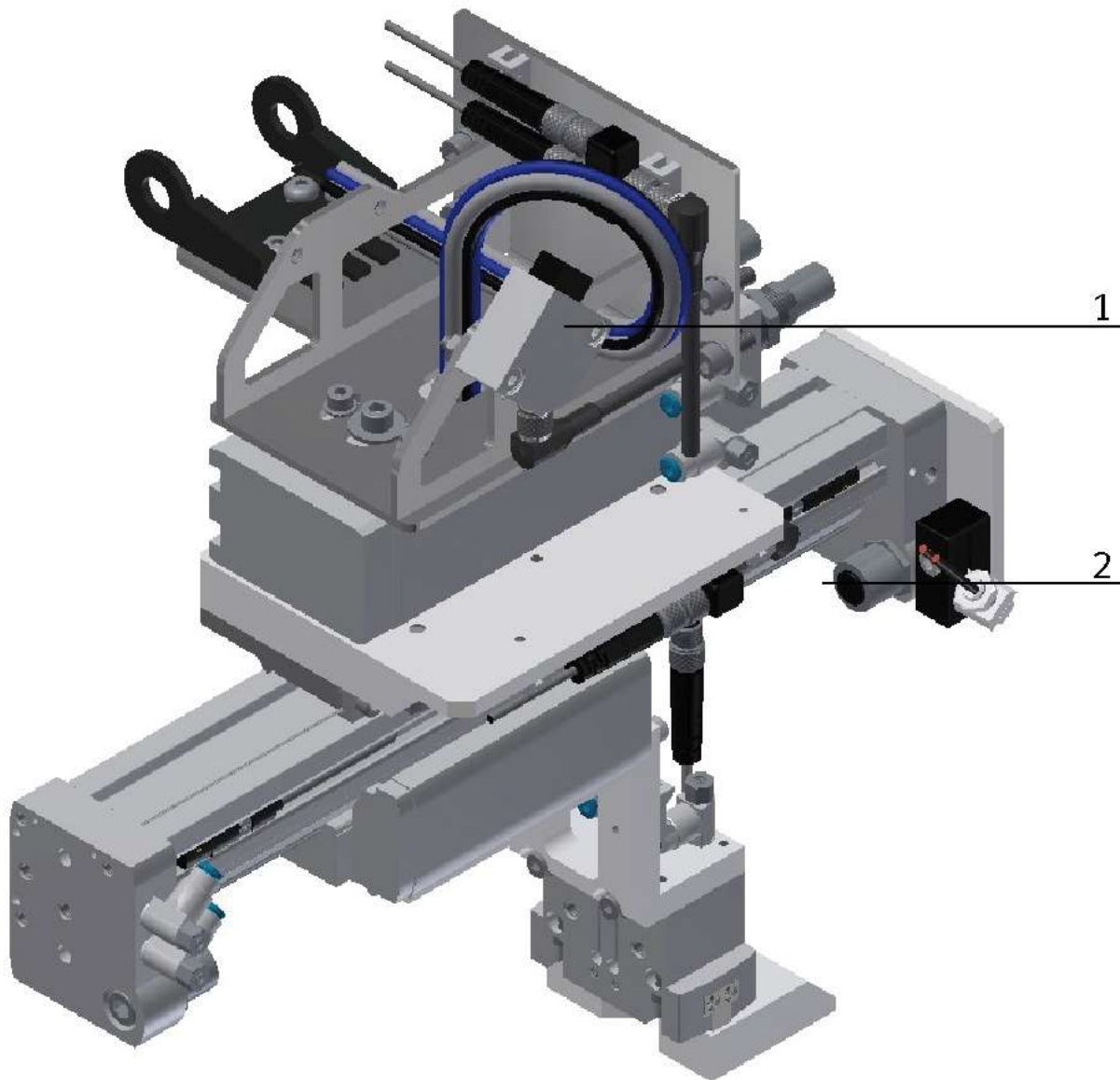

Illustration similar

Position	Description
1	Fibre-optic unit shelf free (BG53) / (D: SOEG-L-Q30-P-A-S-2L)
2	Sensor shelf free / 552836 (SOOC-DS-M6-2-R25)

The through-beam sensor is used for detecting shelves. Flexible fibre optic cables are attached to a fibre-optic unit working with visible infrared. A workpiece located in a shelf disconnects the through-beam sensor and the shelf is identified as occupied.

#### **Requirements**

- Fibre-optic unit is mounted.
- Electric connection of the fibre-optic unit is set up.
- Power supply is available.

#### **Procedure**

1. The fibre-optic heads have to be attached opposite each other on the application.
2. The transmitter and receiver fibre optics have to be adjusted.
3. The fibre optics has to be attached to the fibre-optic unit.
4. It might be required to turn the adjusting screw using a small screwdriver as long as the switching status display (LED) appears.

#### **Remark**

Only 12 turns of the adjusting screw are permitted.

5. Please put a workpiece into a shelf in the sensing range of the through-beam sensor. Now the switching status display will disappear.

#### **Documents**

- Data sheets / Operating instructions  
Fibre-optic unit D: SOEG\_L (8127556) and  
Through-beam sensor 552836 (SOOC-DS-M6-2-R25)



### 7.9 Adjusting the one-way flow control valves

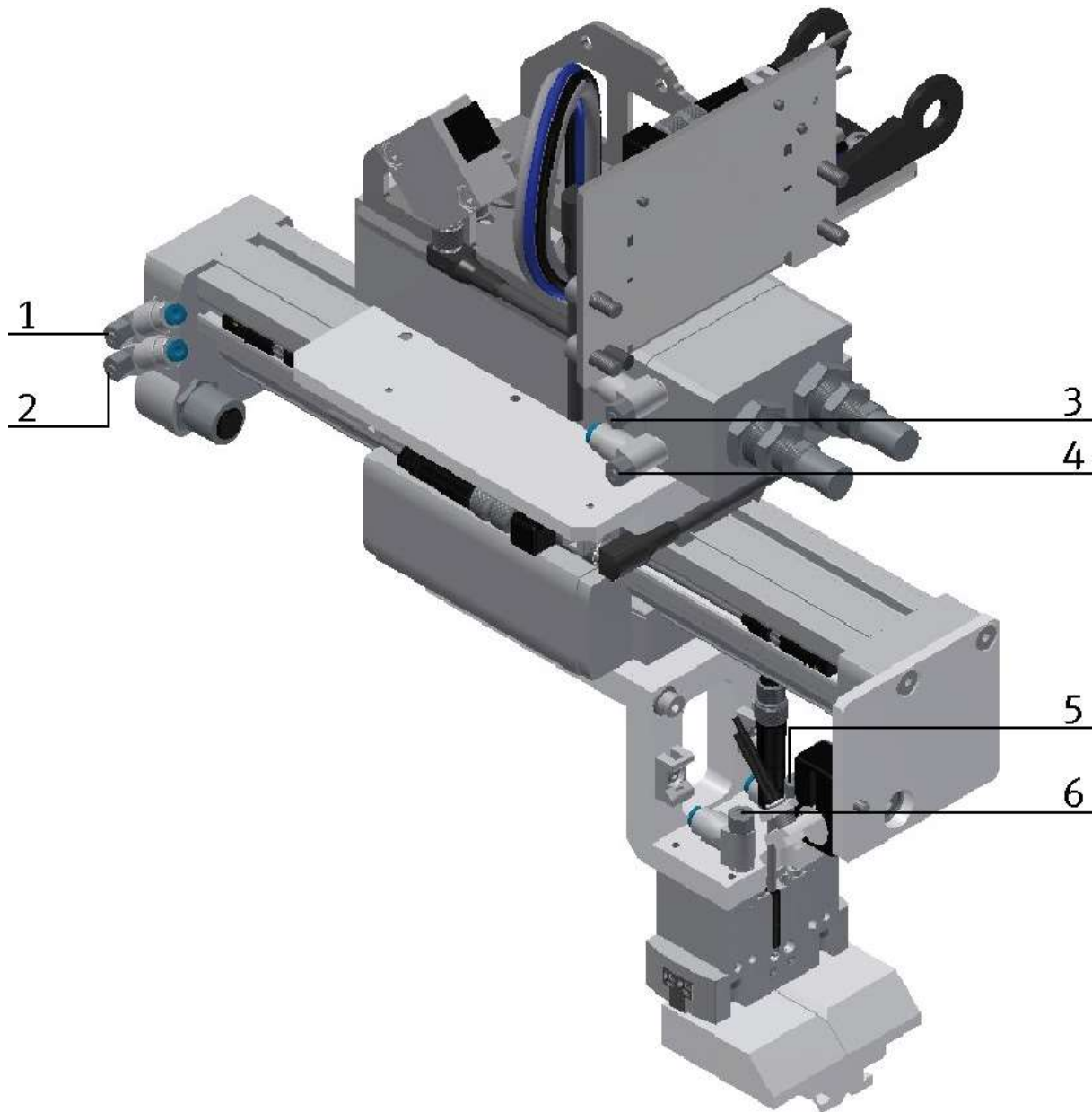

One-way flow control valves / illustration similar

Pos	Description
1	One-way flow control valves GRLA for Y-axis
2	One-way flow control valves GRLA for Y-axis
3	One-way flow control valve GRLA for rotary cylinder
4	One-way flow control valve GRLA for rotary cylinder
5	One-way flow control valves GRLA for gripper
6	One-way flow control valves GRLA for gripper

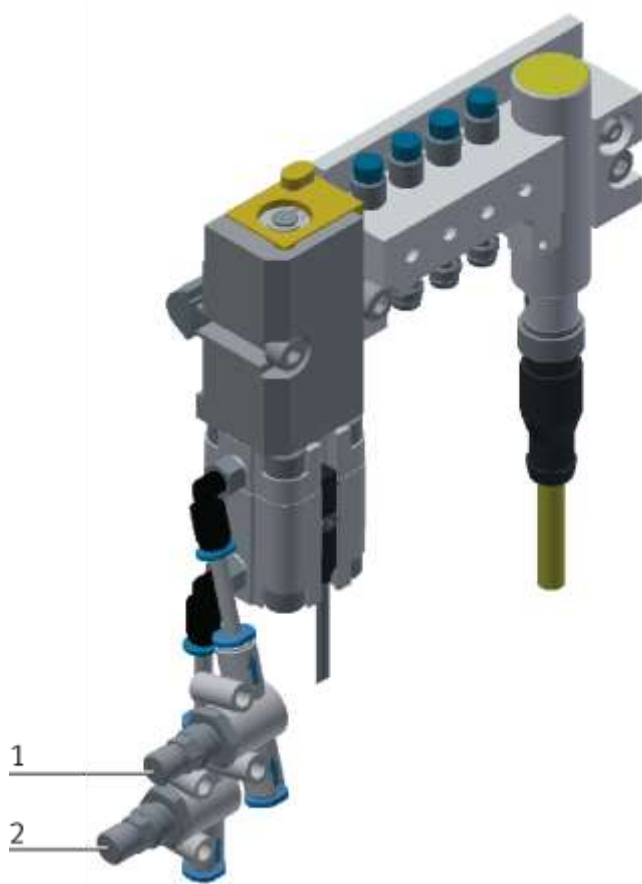

One-way flow control valves / illustration similar

Pos	Description
1	One-way flow control valves GRLA for stopper cylinder
2	One-way flow control valves GRLA for stopper cylinder

One-way flow control valves are used for the regulation of the exhaust air volume of double-acting drive units. In the opposite direction the air flows through the flow control valve having a full cross-sectional flow. The piston is clamped between air cushions by free supply air and throttled exhaust air (improvement of the operating behavior even if the load changes).

**Requirements**

- Pneumatic port of the cylinders is set up.
- Compressed air supply is switched on.

**Procedure**

1. At first, turn off both one-way control valves completely. Then turn them on by about one rotation.
2. Start a test run.
3. Turn on the one-way flow control valves slowly as long as the required piston speed has been reached.

**Documents**

- Data sheets
  - One-way flow control valve (193138)

## 8 Operation

### 8.1 The control units of the ASRS for pallets

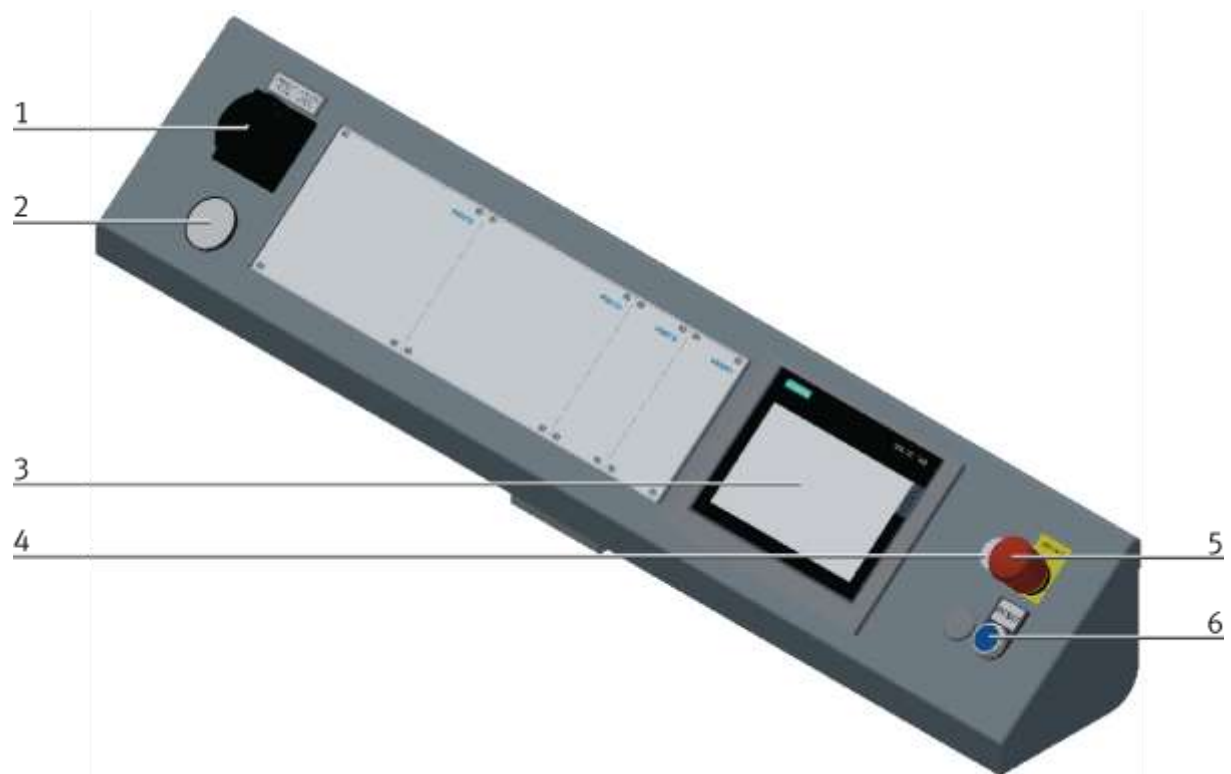

CP Factory control panel / illustration similar

Position	Description
1	Main switch - QB1
2	Manometer
3	Touch Panel – PH1 / Festo panel or Siemens panel possible
4	Network socket- XPN3
5	Emergency- stop switch – F2-FQ1
6	Reset pushbutton – F2-SF1

### 8.2 Sequence description stopper of the Basic Module



Illustration similar

Position	Description
1	Stopper front side
2	Stopper back side

The sequence description is for the stopper of the basic module. The sequence is equal for both sides.

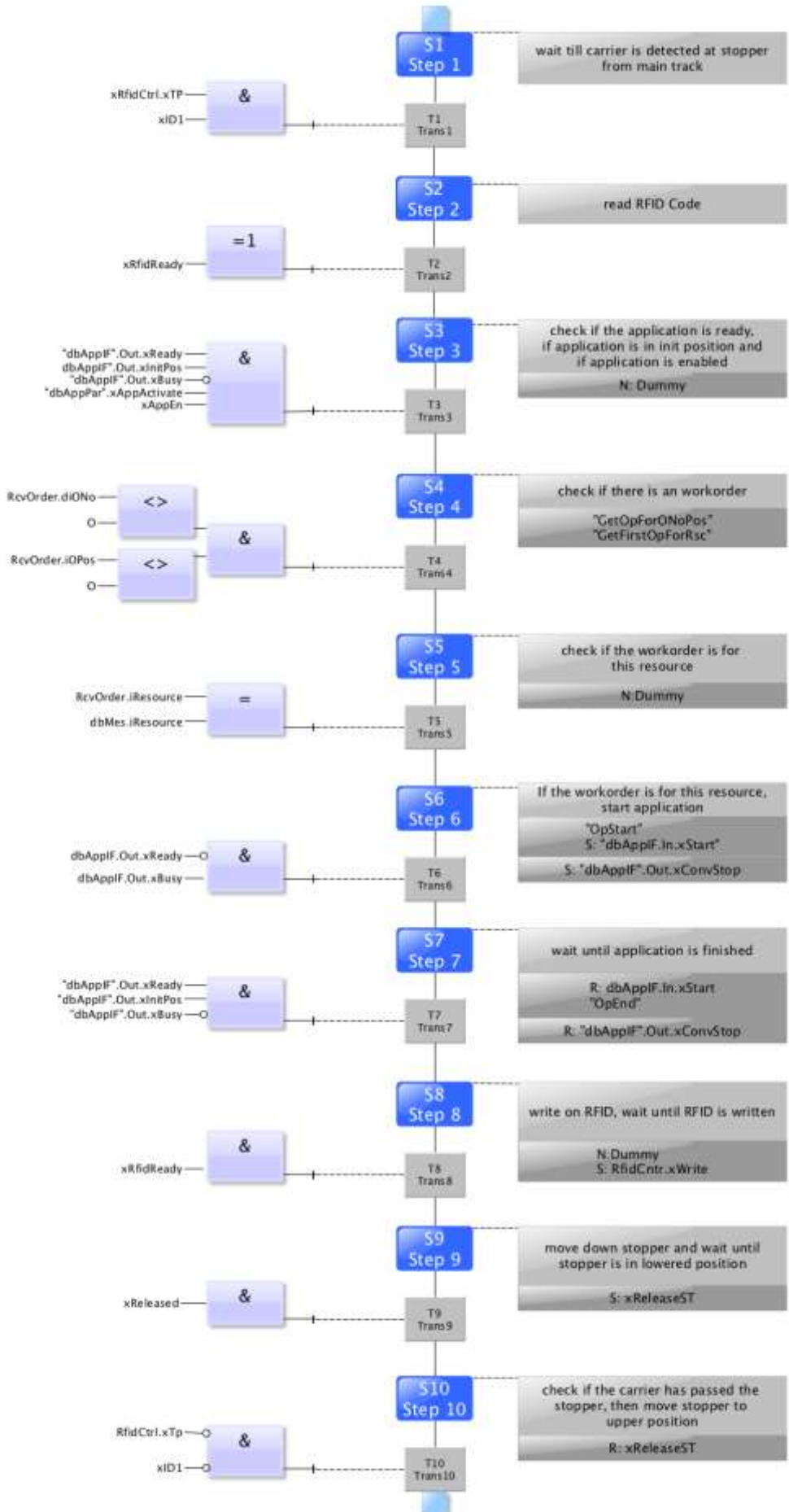

### 8.3 Sequence description of the ASRS for pallets

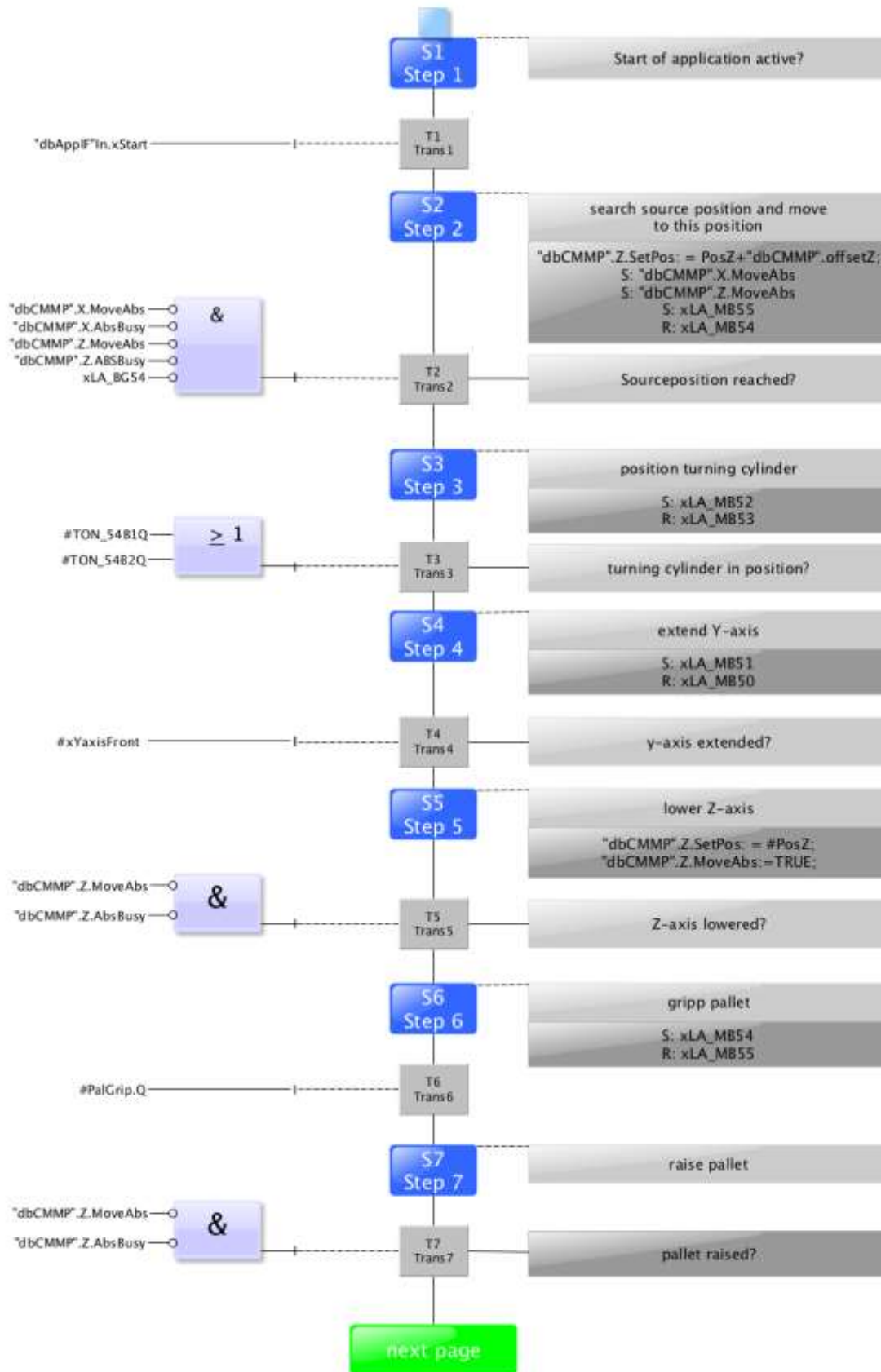

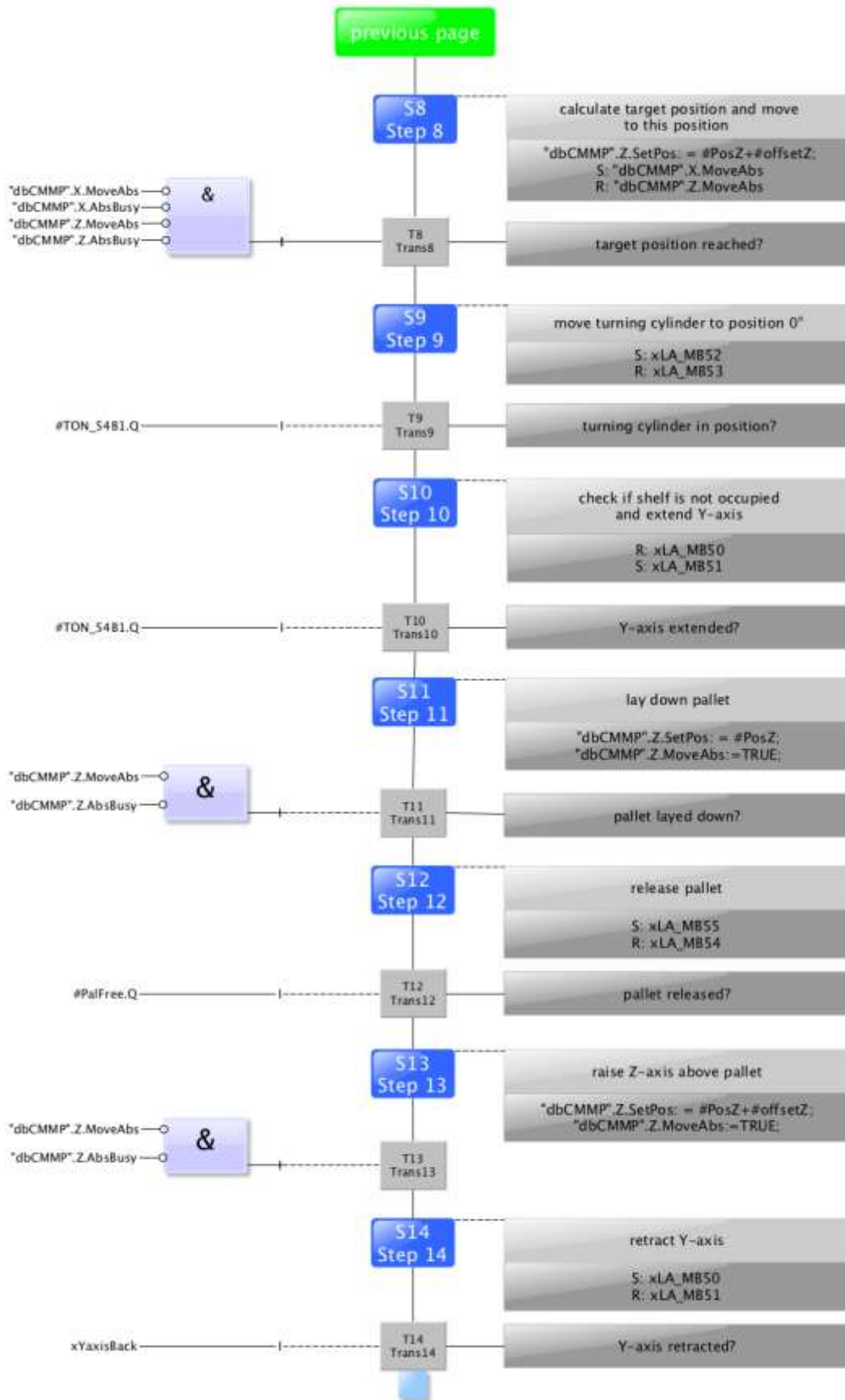

Automatic Mode



8.4 Menu architecture from Panel



Position	Description
1	Description of menu (main or submenu) OR in case of an active Error or an error message, this field is also for announcement
2	Main menu (always shown the same) Operating mode Home: Here the module can be controlled, the mode (default / MES) can be selected, the automatic or the set-up mode can also be operated. Operating mode Setup: Here, the application can be operated manually in setup mode Operating mode Parameter: The parameters of the application are set here, a simulation can be started, the transitions can be defined, or the tape can be set System type: Here the system parameters such as language, time, etc. are set
3	Submenu in the main menu Changing content, depending on the main menu
4	Changing content, depending on the main or submenu
5	Announcement of operation mode automatic or set up
6	Announcement of default or MES Mode

### Log in as an administrator

There are 2 functions in the operation of the HMI that are only available when the operator logs on to the HMI. These functions are the I/O test in the setup mode and the user area.

If one of the functions has been logged in, the other function is also available without the user having to log in again.

The process is explained using the user function as an example.

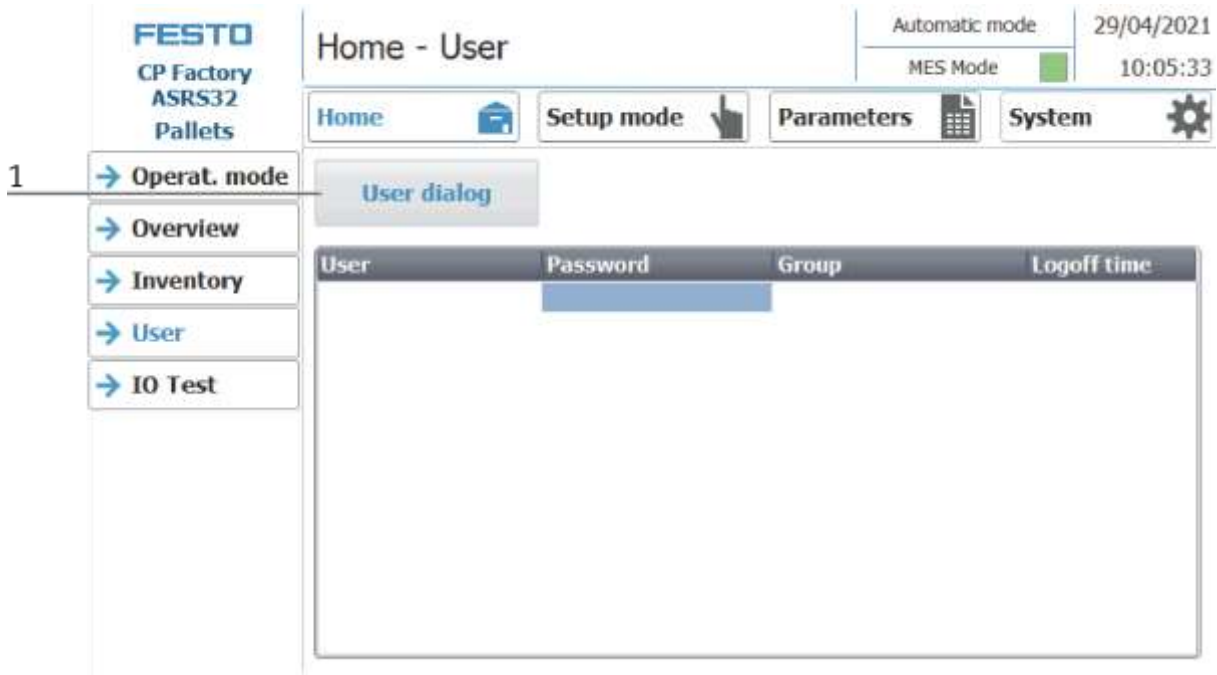

1. With a click on the User Dialog button the following window is opened.

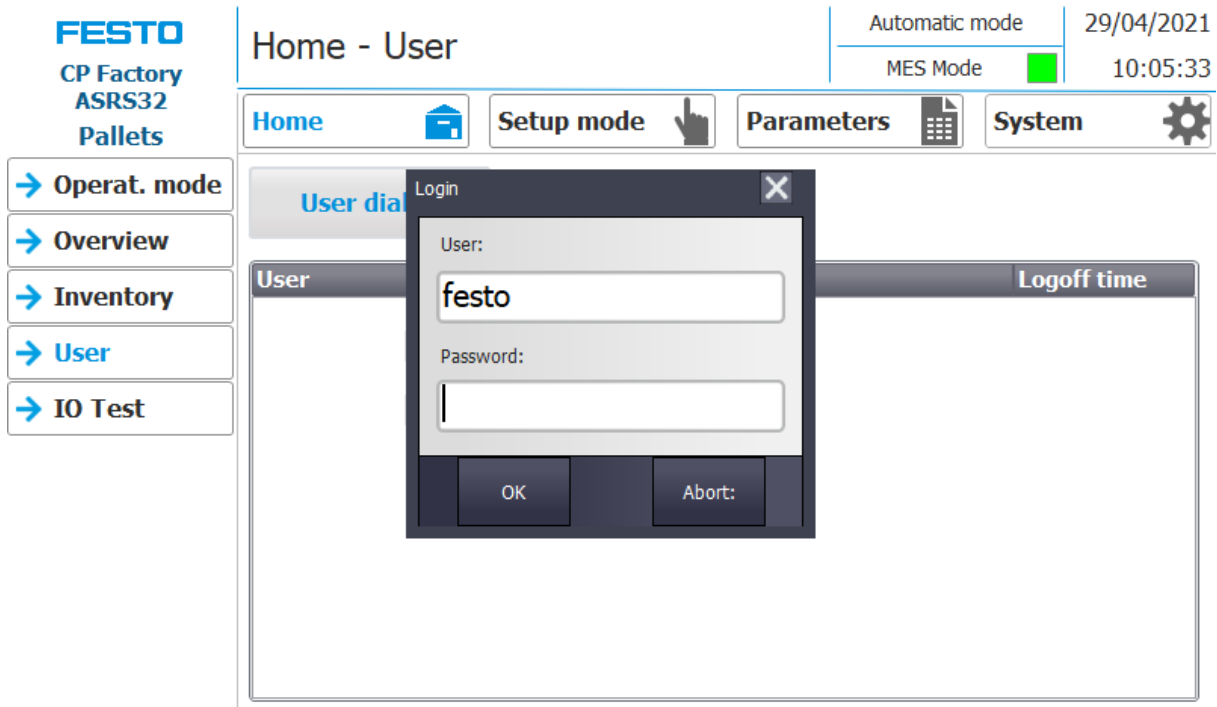

2. If you click in the User or Password fields, the input window opens and the user data can be entered.

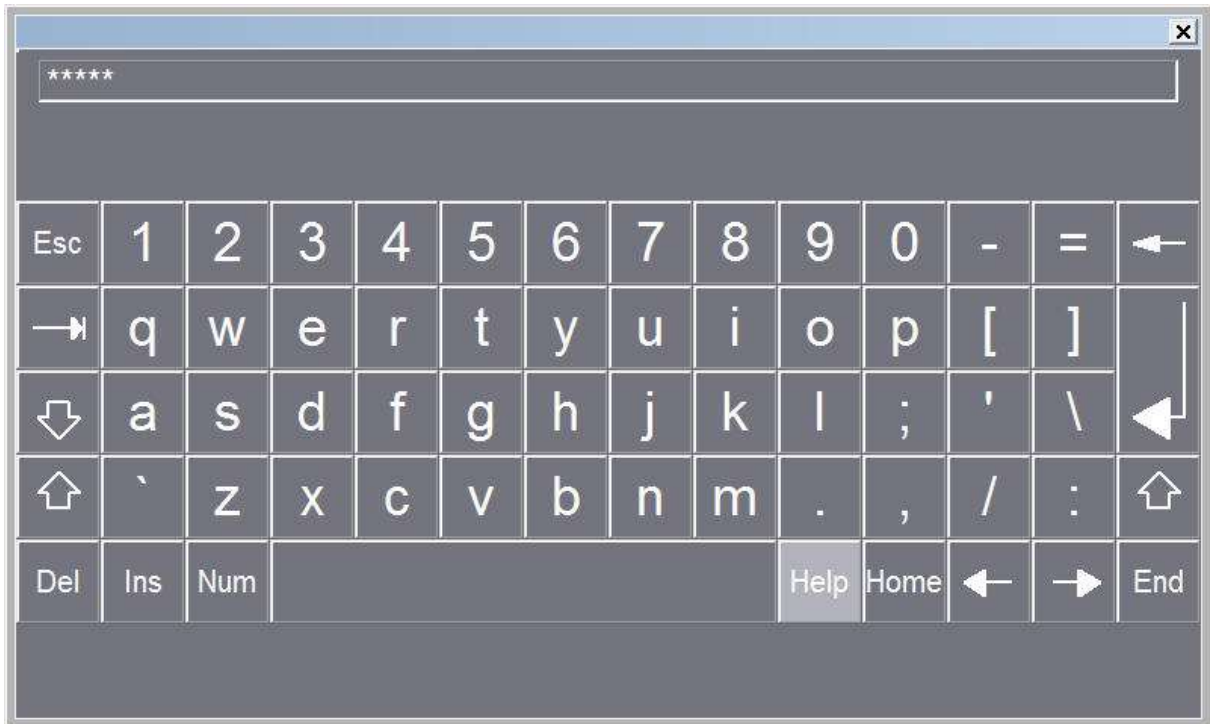

3. The user data can be entered here. The entry is confirmed with the Return key.

User: festo

Password: festo

**FESTO**  
CP Factory  
ASRS32  
Pallets

- Operat. mode
- Overview
- Inventory
- **User**
- IO Test

## Home - User

Automatic mode 29/04/2021  
MES Mode ■ 10:05:33

Home 
Setup mode 
Parameters 
System

User dialog

User	Password	Group	Logoff time
Administrator	*****	Administrator group	5
festo	*****	Administrator group	5
PLC User	*****	Unauthorized	5

4. The user is now logged in as "Administrator" and the functions User and I / O test are available.

## 8.5 Operation modes

The following operation modes are available

- Reset  
The station is moved to its home position
- Setup  
The station runs in set-up mode, actuators can be controlled and monitored
- Automatic  
The station runs in automatic mode, all processes run automatically, no actuators can be controlled.  
There are two modes in the automatic mode: the default mode and the MES mode.

### 8.5.1 Mode

The mode can be set between MES and default, there are two ways to set it.

1. Clicking on the blue marked area opens a pop-up window in which the operating mode can be selected. Other functions are also integrated in the pop-up.
2. The mode can also be set on the Home / Operating mode page.

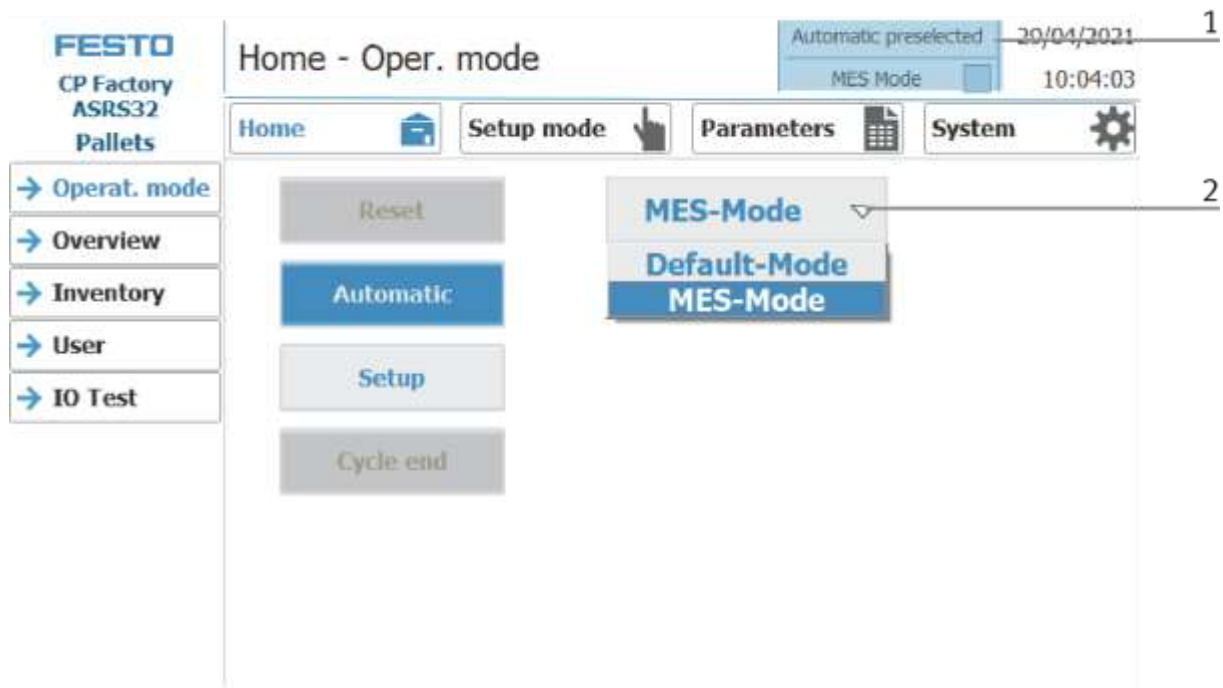

Possibilities of mode

- MES mode  
In the MES mode, all processes are centrally started, executed and monitored by the MES software. All stations must be set to MES mode and automatic start.
- Default Mode  
The automatic sequence is not centrally controlled in the default mode, all information from the transition tables (see chapter "Schematic process flow") is read and processed separately at each station.

### Display MES Mode

Various states are displayed in the Home operating mode on the Overview page.



Position	Description
1	Change to sub menu Overview
2	Display operation state MES is active
3	Display of various functions (marked green if active) Display of various information about the station and its parameters
4	Display of the order data of the current carrier at stopper 1 and stopper 2

### Display Default mode

Various states are displayed in the Home operating mode on the Overview page.

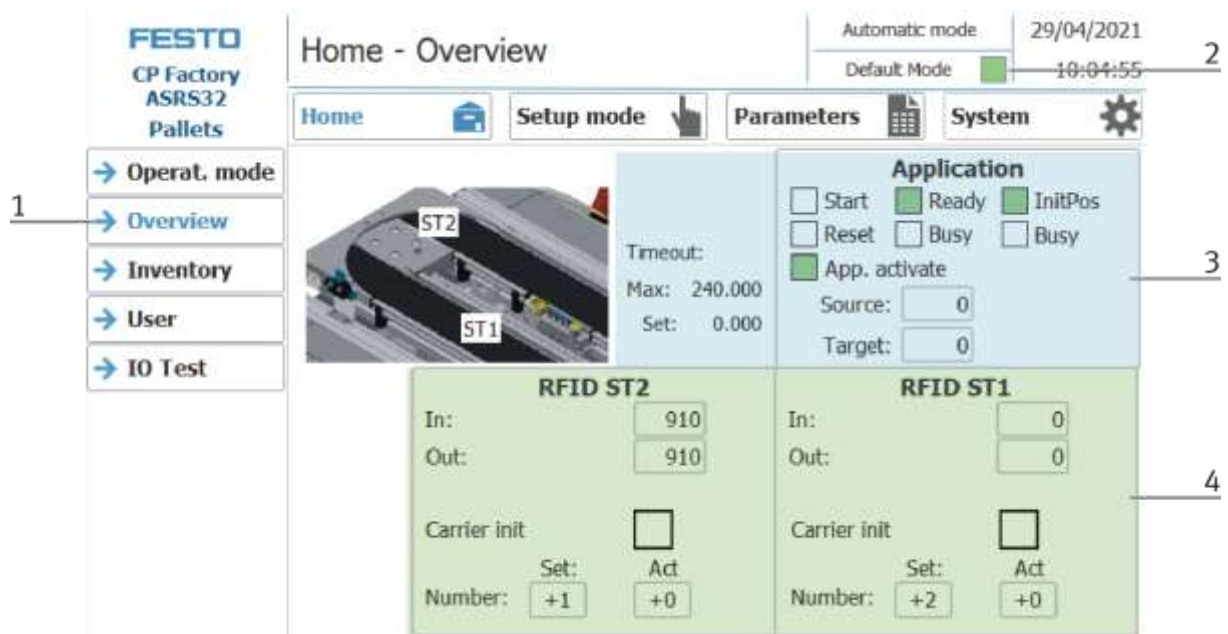

Position	Description
1	Change to sub menu Overview
2	Display default mode is active
3	Display of various functions (marked green if active) Display of various information about the station and its parameters
4	Display of RFID statecode at stopper 1 and stopper 2

### 8.5.2 Operation mode Reset

In the operation mode Reset, the station is moved to its home position.



1. After switching on the station, the Reset button flashes, press this to move the station into its home position.
2. The operating mode Reset is displayed here during the process.

### 8.5.3 Operation mode Setup

In operation mode Setup, all sensors can be displayed and actuators can be controlled from the HMI. This is used for troubleshooting or during commissioning.

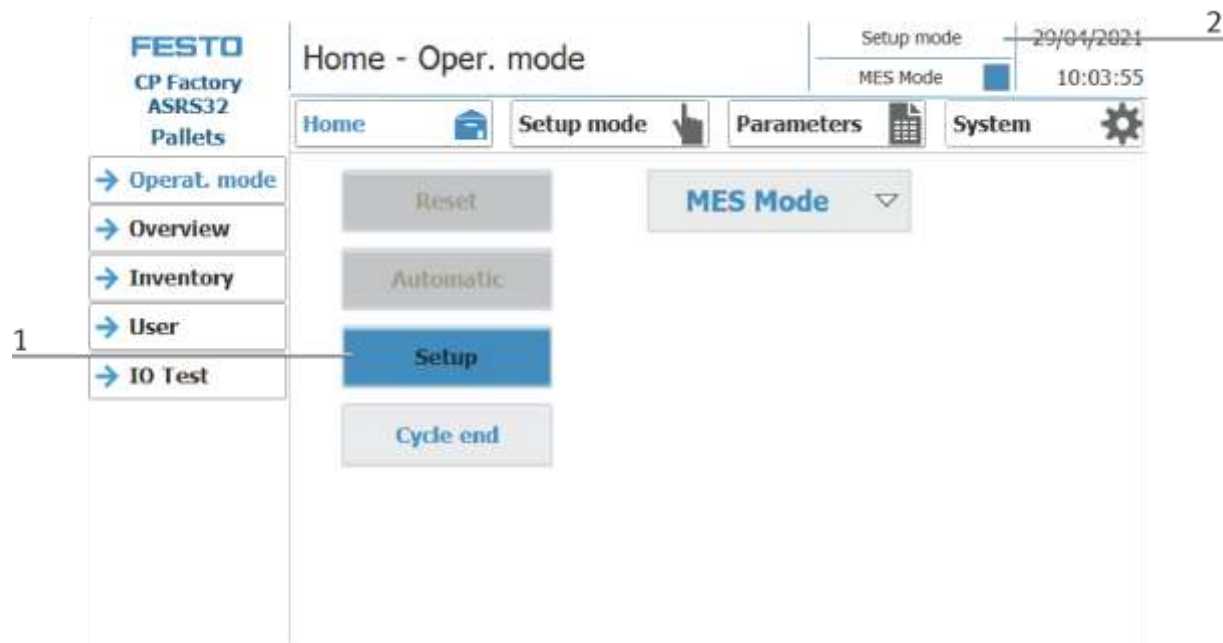

1. Automatic mode is not active and the Setup button is not greyed out - press the Setup button to activate the Setup mode.
2. The current operation mode is displayed here



**Set up application**

1. Click the Setup mode button
2. Select application.

**FESTO**  
CP Factory  
ASRS32  
Pallets

Setup - Appl. Storage

Setup mode 29/04/2021  
MES Mode 14:05:07

1 Home Setup mode Parameters System

2 → Application  
→ Belt 1-2  
→ Stopper 1  
→ Stopper 2

X	599.84	Pal. Av.	BG53	OVRD	NOM	50
Z	549.78			OVRD	ACT	50

Z+	Gripper in	Gripper out	Pallet ungrip	Pallet grip
Z-	X-	X+	Turn 0°	Turn 180°
Pallet place	Pallet pick	Save	Move	Test Cykle 16 - 1 - 16
-->	0.1	1.0	10.0	REF

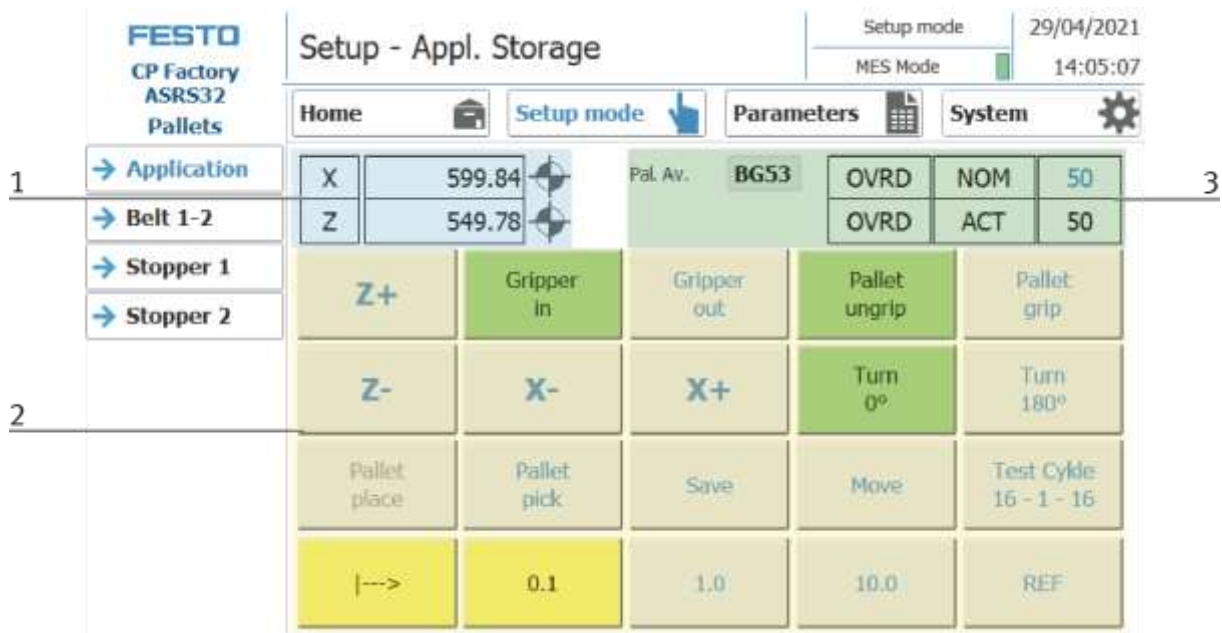

Position	Description
1	Display of the X and Z coordinates
2	<p>These buttons have no function in automatic mode (they are grey) only in Setup mode they are blue, and the buttons have a function.</p> <p>Button Z+: Move Z-axis upwards (lights up green when active)</p> <p>Gripper in button: the gripper retracts (lit green when active)</p> <p>Button Gripper out: the gripper is extended (lights up green when active)</p> <p>Button pallet ungrip: the gripper opens and the pallet is dismissed (lit green when active)</p> <p>Button pallet grip: the gripper picks up the palette (lit green when active)</p> <p>Button Z-: Move Z-axis to lower position (lit green when active)</p> <p>Button X-: move X-axis to the left (lights up green when active)</p> <p>Move button X + X-axis to the right (lit green when active)</p> <p>Turn button 0 °: Turn gripper to position 0 ° (lit green when active)</p> <p>Turn button 180 °: Turn gripper unit to position 180 ° (lit green when active)</p> <p>Pallet place button: Place palette in shelf or on conveyor (lit green when active)</p> <p>Button pallet pick: Lift pallet off conveyor or shelf (lit green when active)</p> <p>Save button: Save the moved position (window for position number opens - see following figure)</p> <p>Move button: move to position (window for position number opens - see following figure)</p> <p>Button Test cycle 16-1-16: Move off test cycle, from position 16 to position 1 and again to 16</p> <p>Button 0.1: Preselection of relative positioning by 0.1 mm (lights up yellow when active)</p> <p>Button 1.0: Preselection of relative positioning by 1 mm (lit yellow when active)</p> <p>Button 10.0: Preselection of relative positioning by 10 mm (lit yellow when active)</p> <p>Button REF: In set-up mode, the homing of the axes is started here.</p>
3	<p>Input and display of the override</p> <p>OVRD target - default override</p> <p>OVRD is - displaying the current override</p> <p>Pal. Av: Display sensor pallet available (lights up green when active)</p>

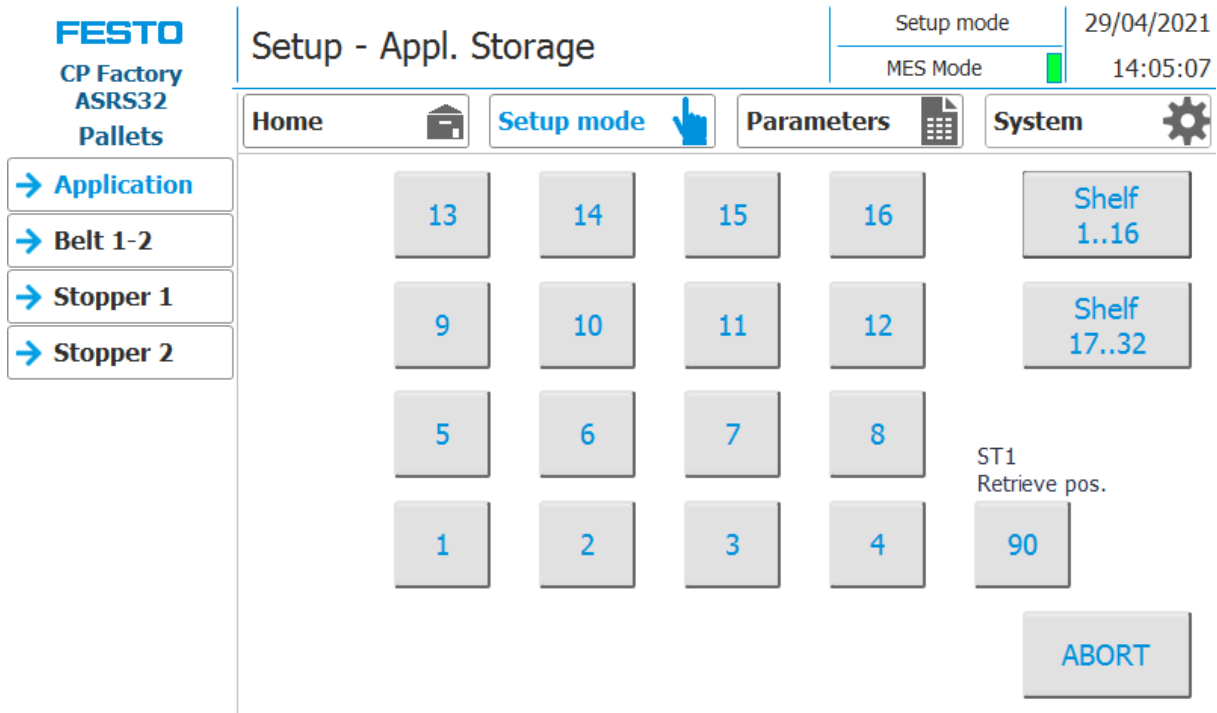

Window to choose position

With the button Shelf 1 ... 16 the positions shown here can be approached or saved.

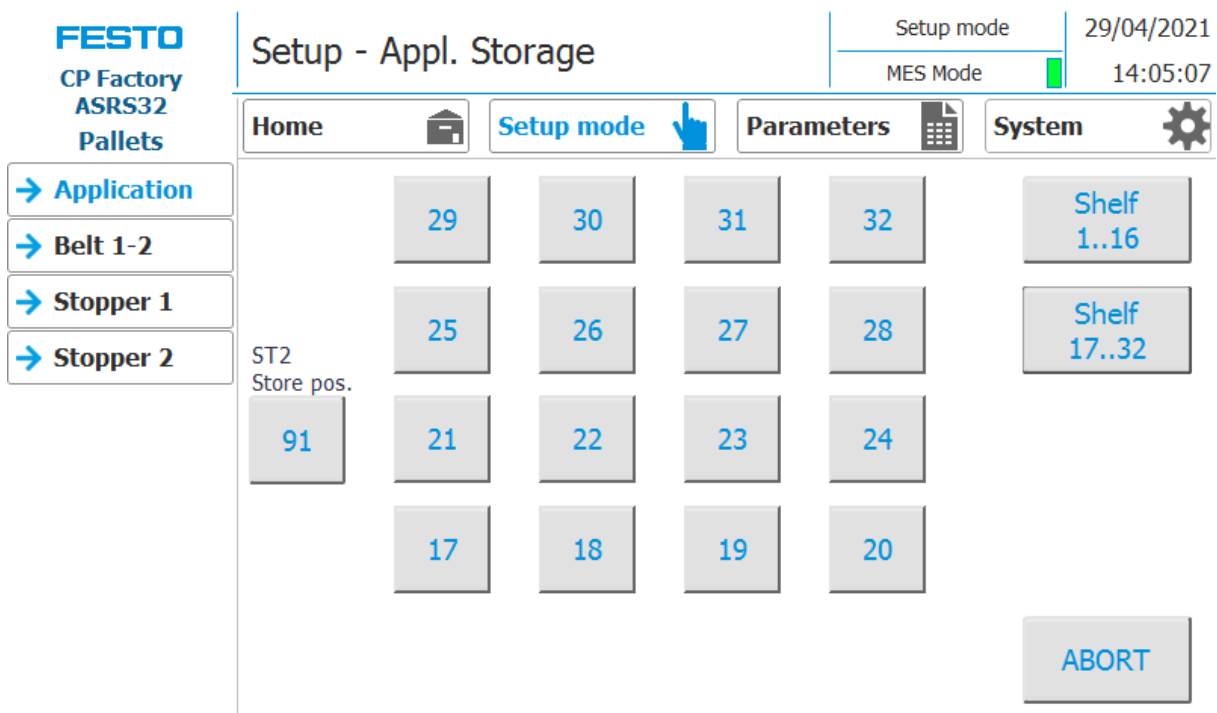

The button Shelf 17 ... 32 changes the window to the other item numbers

With the button ST1 Retrieve pos. the position on the conveyor belt is meant.

With the button ST2 store position the position on the conveyor belt is meant.

With the button Abort the process can be aborted.

### Setup belt 1-2

1. Click the Setup mode button
2. Select belt 1-2; the functions of the conveyor belts are displayed and / or controlled here.

The screenshot shows the 'Setup - Belt 1-2' interface. At the top left, it says 'FESTO CP Factory ASRS32 Pallets'. The title bar reads 'Setup - Belt 1-2'. On the right, it shows 'Setup mode' and 'MES Mode' with a date '17/07/2020' and time '13:22:06'. Below the title bar is a navigation bar with 'Home', 'Setup mode' (highlighted with a hand icon), 'Parameters', and 'System' (gear icon). On the left, a vertical menu has 'Application', 'Belt 1-2' (selected), 'Stopper 1', and 'Stopper 2'. The main area contains two tables for 'Belt 1' and 'Belt 2'. Each table has columns for 'Left', 'Drive', and 'Right'. The 'Belt 1' table has 'Drive1' and the 'Belt 2' table has 'Drive2'. The functions listed are 'backward (QA1\_A2)', 'Presef. slow', 'creep feed (QA1\_A3)', and 'forward (QA1\_A1)' for Belt 1, and similar for Belt 2. At the bottom, a camera view shows two conveyor belts with labels BG37, BG36, BG26, and BG27.

Belt	Left	Drive	Right
Belt 1	backward (QA1_A2)	Drive1	forward (QA1_A1)
		Presef. slow	creep feed (QA1_A3)
Belt 2	backward (QA2_A2)	Drive2	forward (QA2_A1)
		Presef. slow	creep feed (QA2_A3)

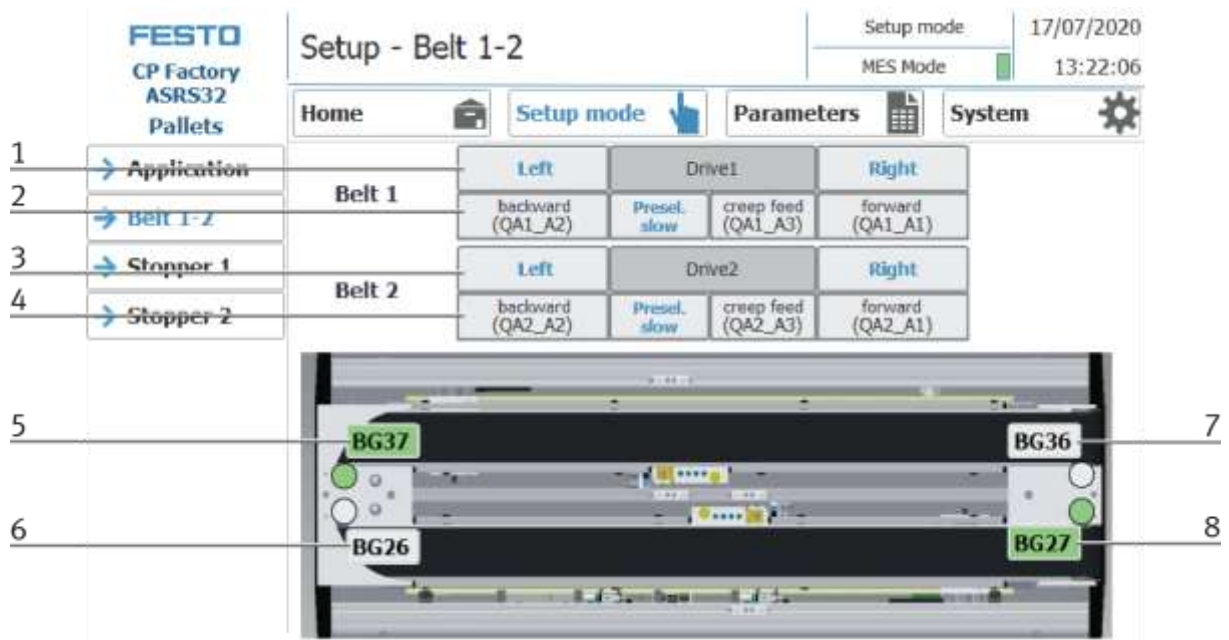

Position number	description
1	Run the conveyer 1 left / right Left: conveyer moves counter clockwise to the left Drive1: Display conveyor belt 1 Right: conveyer moves clockwise to the right
2	Backward: Move the conveyer 1 to the left (actuator QA1_A2 is activated, lights up blue when active) Preselection slow: Slowly set the conveyer speed Creep feed: Move the conveyer 1 slowly (actuator QA1_A3 is activated, lights up blue when active) Forward: Move the conveyer 1 to the right (actuator QA1_A1 is activated, lights up blue when active)
3	Run the conveyer 2 left / right Left: conveyer moves counter clockwise to the left Drive2: Display conveyor belt 1 Right: conveyer moves clockwise to the right
4	Backward: Move the conveyer 2 to the left (actuator QA2_A2 is activated, lights up blue when active) Preselection slow: Slowly set the conveyer speed Creep feed: Move the conveyer 2 slowly (actuator QA2_A3 is activated, lights up blue when active) Forward: Move the conveyer 2 to the right (actuator QA2_A1 is activated, lights up blue when active)
5	Sensor BG37 Indicator conveyer outlet (lights up green when active)
6	Sensor BG26 Indicator conveyer inlet (lights up green when active)
7	Sensor BG36 Indicator conveyer inlet (lights up green when active)
8	Sensor BG27 Indicator conveyer outlet (lights up green when active)

### Setup Stopper 1

1. Click the Setup mode button
2. Select stopper - the functions of the stopper position are displayed and / or controlled here.

The screenshot shows the 'Setup - Stopper 1' configuration interface. On the left, a navigation menu is visible with options: Application, Belt 1-2, Stopper 1 (selected), and Stopper 2. The top right corner displays 'Setup mode' and 'MES Mode' with a progress bar, and the date '17/07/2020' and time '13:22:18'. The main interface features a navigation bar with 'Home', 'Setup mode' (highlighted), 'Parameters', and 'System' buttons. Below this, there are input fields for 'lower (K1\_MB20)', 'G1\_BG20', and 'Stopper' with values '00000ms' and '733'. A 3D model of the stopper assembly is shown with labels: BG21, BG22, BG23, BG24, TF80, MB20, BG55, BG54, and BG20. At the bottom, an 'RFID Data' table is displayed with 'MES Mode' and 'Default Mode' sections.

		RFID Data				
init		Carrier ID:	4	PNo:	+0	Tag present
read	<b>MES Mode</b>	ONo:	+0	Res. ID:	+0	Ready
write		OPos:	+0	Operation:	+0	Busy
		State code:	0			Error
Delete data	<b>Default Mode</b>	Par. 1:	+0	Par. 2:	+0	Timeout
		Par. 3:	+0	Par. 4:	+0	

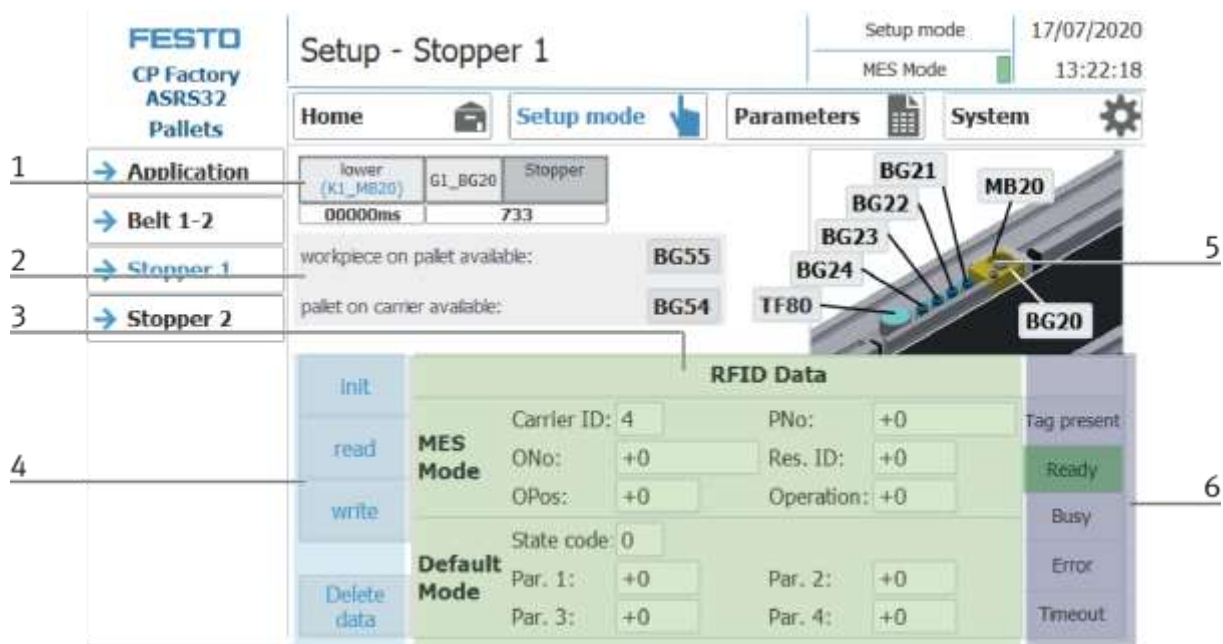

Position number	description
1	Move down the stopper 1 Lower: Move stopper down (actuator G1_MB20 is activated, lights up blue when active) G1_BG20: Sensor G1_BG20 Stopper lowered (lit green when active) Stopper: Indicator stopper
2	Display of the active sensors (lit green when active) at handling
3	RFID area MES Mode: Displays the job data Default Mode: Displays the RFID status
4	Write and read RFID area Initialize: Set RFID data to zero read: Read RFID data write: Write current data on RFID Delete data: all data in the input mask are deleted - not directly on the RFID (for easier entry)
5	Range Display of the active sensors (lit green when active) and actuators (lit orange when active) at the stopper
6	Display of RFID reading status

### Setup Stopper 2

1. Click the Setup mode button
2. Select stopper - the functions of the stopper position are displayed and / or controlled here.

The screenshot shows the 'Setup - Stopper 2' configuration interface. On the left, a navigation menu is visible with options: Application, Belt 1-2, Stopper 1, and Stopper 2. The 'Stopper 2' option is selected. The main area displays a 3D model of the stopper assembly with components labeled BG31, BG32, BG33, BG34, TF81, MB30, BG57, and BG56. Below the model, there are two status indicators: 'workpiece on pallet available:' and 'pallet on carrier available:'. At the bottom, an 'RFID Data' table is shown with fields for Carrier ID, PNo, ONo, Res. ID, OPos, Operation, State code, and Par. 1-4. The 'MES Mode' is set to 'Ready'.

		RFID Data				
init		Carrier ID:	2	PNo:	+0	Tag present
read	<b>MES Mode</b>	ONo:	+0	Res. ID:	+0	Ready
write		OPos:	+0	Operation:	+0	Busy
	<b>Default Mode</b>	State code:	1			Error
Delete data		Par. 1:	+0	Par. 2:	+0	Timeout
		Par. 3:	+0	Par. 4:	+0	



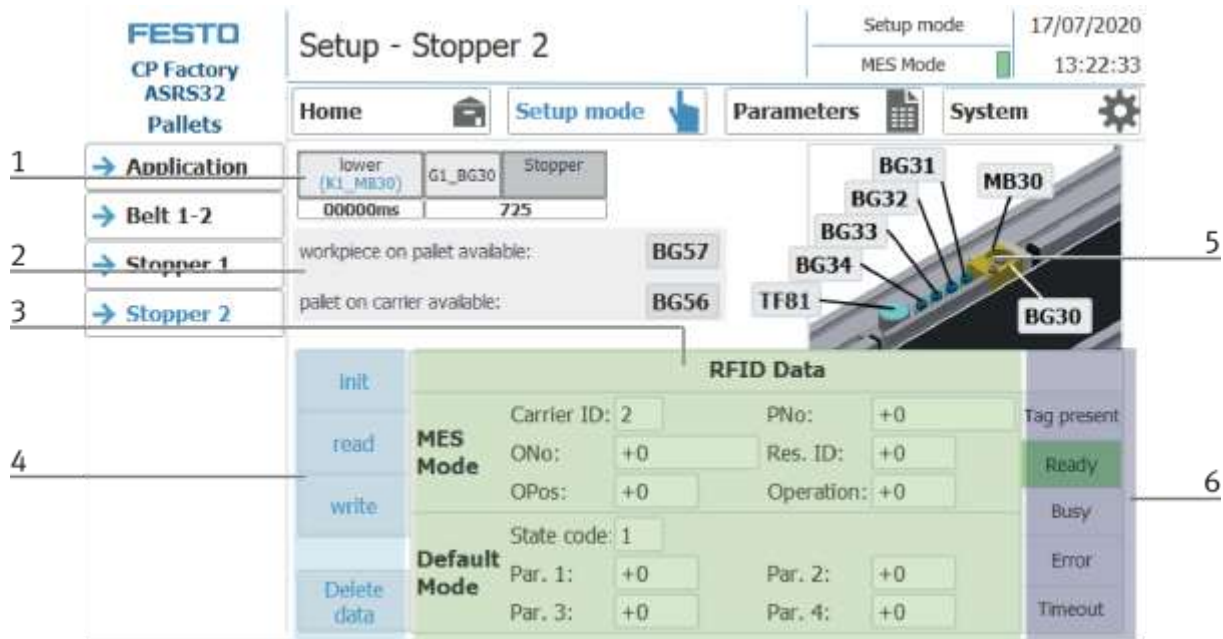

Position number	description
1	Move down the stopper 2 Lower: Move stopper down (actuator G1_MB20 is activated, lights up blue when active) G1_BG20: Sensor G1_BG20 Stopper lowered (lit green when active) Stopper: Indicator stopper
2	Display of the active sensors (lit green when active) at handling
3	RFID area MES Mode: Displays the job data Default Mode: Displays the RFID status
4	Write and read RFID area Initialize: Set RFID data to zero read: Read RFID data write: Write current data on RFID Delete data: all data in the input mask are deleted - not directly on the RFID (for easier entry)
5	Range Display of the active sensors (lit green when active) and actuators (lit orange when active) at the stopper
6	Display of RFID reading status

### Set up application parameters

1. Click on the Parameter button
2. Select application - the parameters of the application can now be set up here.

The screenshot displays the 'Parameters - Application' configuration window. At the top left, the logo for 'FESTO CP Factory ASRS32 Pallets' is visible. The main title is 'Parameters - Application'. In the top right corner, the 'Setup mode' is set to '17/07/2020' and 'MES Mode' is '13:18:46'. Below the title bar, there is a navigation menu with buttons for 'Home', 'Setup mode', 'Parameters', and 'System'. The 'Parameters' button is highlighted. On the left side, a vertical menu contains 'Application', 'Transitions', and 'Belt, Stopper', with 'Application' selected. The main content area contains the following parameters:

Parameter 1 application:	<input type="text" value="90"/>
Parameter 2 application:	<input type="text" value="32"/>
Enable application	<input checked="" type="checkbox"/>
Stop belt before start application	<input type="checkbox"/>
Application identifier:	<input type="text" value="0"/>

Position number	description
1	Here the parameter 1 – the function can be inserted
2	Here the parameter 2 – the partnumber can be inserted
3	Here the application module can be activated (tick set). If no application module is activated, the carrier is stopped at the stopper and released again without processing.
4	Stop belt before start application: the belt is stopped before the application begins to start
5	Application identifier: here it is possible to insert the application number

## I/O Test

The screenshot displays the 'Home - IO test' interface. At the top right, it indicates 'Setup mode' is active on 29/04/2021 at 10:07:10. The main area is divided into two sections: 'Eingänge' (Inputs) and 'Ausgänge' (Outputs). Each section contains a 4x8 grid of values (0.0 to 0.7) under 'Byte' headers. In the 'Eingänge' section, values 0.0, 0.1, and 0.6 are highlighted in green. In the 'Ausgänge' section, values 0.0, 0.2, and 0.5 are highlighted in orange. A red vertical box on the right contains the text: 'Enable Outputs CAUTION Program return of OB1 No cyclic program call'. The interface includes a top navigation bar with 'Home', 'Setup mode', 'Parameters', and 'System' buttons. A left sidebar contains menu items: 'Operat. mode', 'Overview', 'Inventory', 'User', and 'IO Test'. The 'IO Test' item is highlighted with a blue arrow. The 'Setup mode' button is also highlighted with a blue arrow.

Position number	Description
1	Setup mode must be active
2	Choose Home
3	Choose I/O Test
4	By clicking in this area, the outputs are enabled and can be activated. A login as "Administrator" is required.

The screenshot shows the 'Home - IO test' interface in 'Setup mode'. At the top right, it displays 'Setup mode' and 'MES Mode' with a date of '29/04/2021' and a time of '10:07:10'. The main navigation bar includes 'Home', 'Setup mode', 'Parameters', and 'System'. On the left, a menu lists 'Operat. mode', 'Overview', 'Inventory', 'User', and 'IO Test'. The central area contains two 8x4 grids of digital outputs. The left grid, 'Eingänge', has columns '0', '1', '2', and '3' under the heading 'Byte'. The right grid, 'Ausgänge', has columns '0', '1', '2', and '3' under the heading 'Byte'. A red vertical banner on the right contains the text: 'Enable Outputs CAUTION Program return of OB1 No cyclic program call'. Two callout lines, labeled '1' and '2', point to the '0.0' field in the 'Ausgänge' grid and the '0.5' field in the 'Ausgänge' grid, respectively.

Position number	Description
1	By clicking in a field, this digital output is activated (orange if active)
2	By clicking again in this field, the outputs are blocked again

### Exit operation mode setup

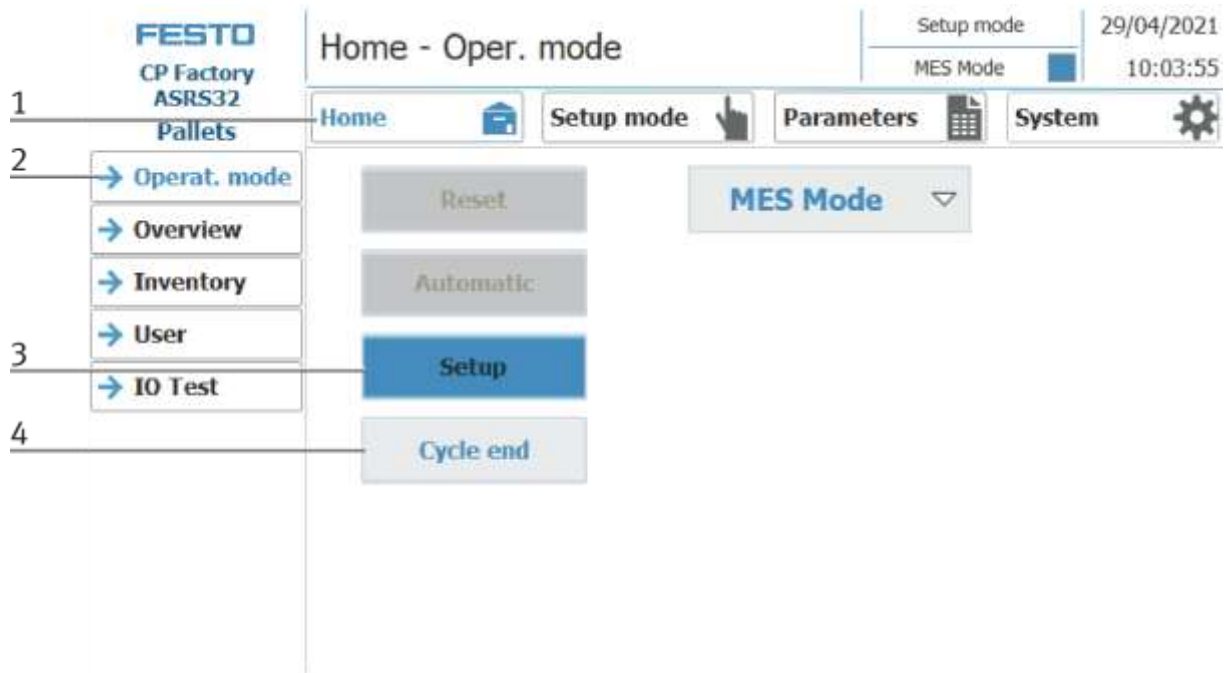

1. Press Home button
2. Press Operat. mode
3. Setup mode is active, button lights up blue
4. Press the cycle end button to end the operation mode setup.

### 8.5.4 Operation mode automatic

In automatic mode, the chosen automatic processes can be processed at the station. Depending on the selection of the mode, the processes are controlled via the transition tables (default) or via MES.



1. Automatic button flashing blue – Press Button to activate operation mode automatic

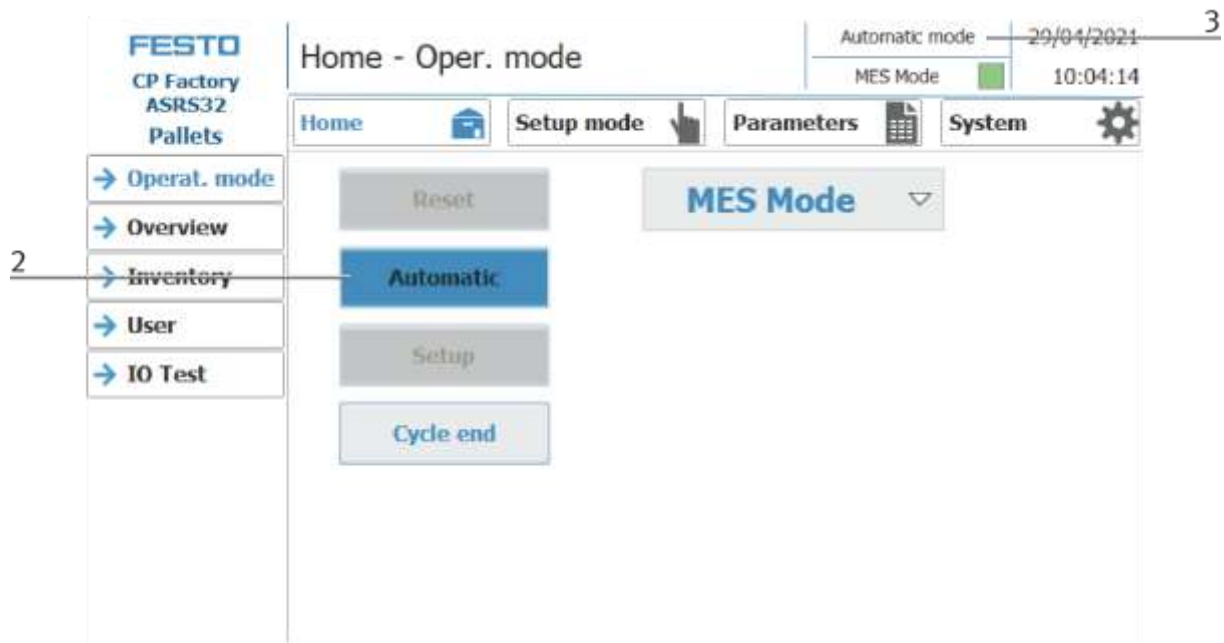

2. Operation mode automatic is active, button lights up blue

3. Announcement of active operation mode automatic

**8.5.5 Main menu - Home  
Sub menu operation mode**

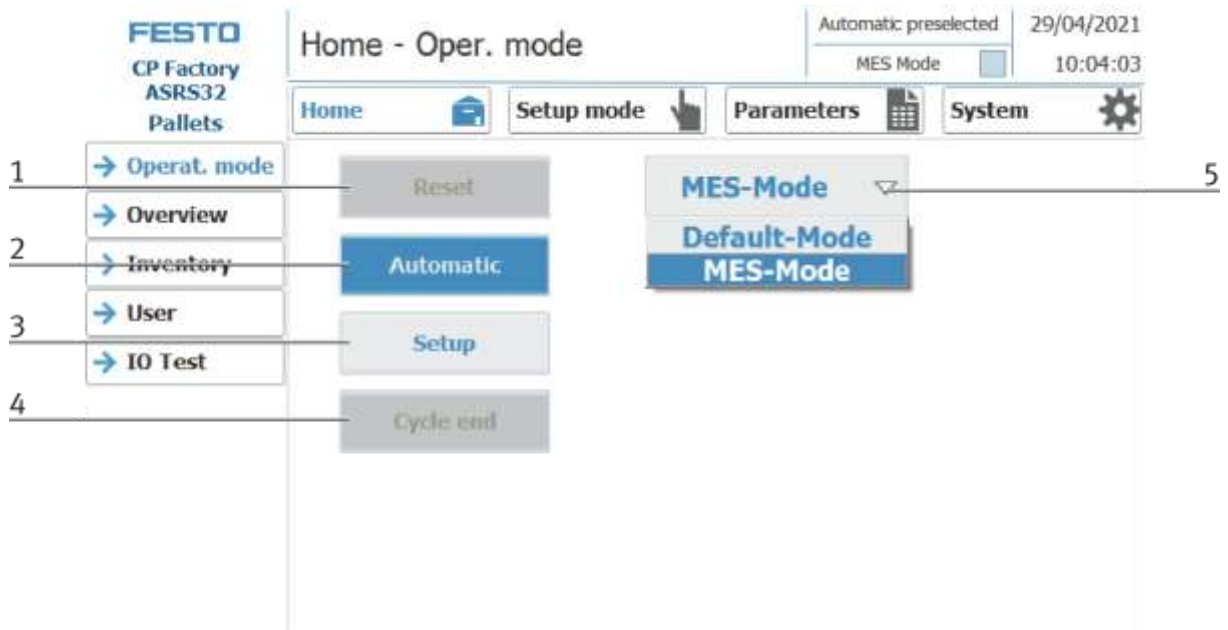

In the operating mode Home, the operating mode and the wished mode (MES or Default) can be selected and started.

Position	Description
1	Reset Button: start reset sequence
2	Automatic Button: An automatic sequence is started here depending on the mode (default / MES)
3	Setup Button: Here the application module can be controlled manually and sensors can be displayed. To put an application module into operation or suitable for troubleshooting. There is no difference in the mode - the setup mode is independent of the default or MES mode.
4	Cycle end Button: The currently active operating mode is stopped here.
5	Select the operation mode: Default - Automatic sequence is executed with the stored transitions MES: automatic is fully controlled by MES software



**Submenu Overview**

Various states are displayed in the Home operating mode on the Overview page.  
(changing contents depending on the selected operating mode)



Position	Description
1	<p>Application area: here the status of the station is displayed</p> <p>Start: Green when started                      Ready: Green when ready                      Init Pos.: Green when the basic setting is reached                      Reset: Green when the application is directed                      Busy: Green when the application processes an order                      RFID Busy: green when an RFID code is read or written                      Application active: green when the application is logged on to the basic module                      Source: The source position is displayed or entered here                      Target: The target position is displayed or entered here                      Timeout: The max. timeout and the actual timeout are announced here</p>
2	<p>Area Order Carrier ST1- here the information provided by MES on the carrier</p> <p>Carrier ID: Carrier number                      ONo: Order number                      OPos: Order position                      PNo: Part number                      OpNo: Operation Number                      Resc ID: Resource</p> <p>Area Order Carrier ST2- here the information provided by MES on the carrier</p> <p>Carrier ID: Carrier number                      ONo: Order number                      OPos: Order position                      PNo: Part number                      OpNo: Operation Number                      Resc ID: Resource</p>

**FESTO**  
CP Factory  
ASRS32  
Pallets

Conveyor Stop by Sensor / Energy-Mode: conveyor belt instance Drive1 is stopped!

Automatic mode 29/04/2021  
MES Mode ■ 10:04:30

Home Setup mode Parameters System

→ Operat. mode  
→ Overview  
→ Inventory  
→ User  
→ IO Test

Time	Date	Status	Text
09:29:13	22/02/2021	K	Conveyor Stop by Sensor / Energy-Mode: conveyor belt instance Drive1 is stopped!

Error messages are also displayed in the overview window.

**Submenu Inventory**

**FESTO**  
CP Factory  
ASRS32  
Pallets

Home - Inventory

Automatic mode 29/04/2021  
MES Mode  10:05:22

Home Setup mode Parameters System

→ Operat. mode  
→ Overview  
→ **Inventory**  
→ User  
→ IO Test

25 13 ONo: 0 Pos: 0	25 14 ONo: 0 Pos: 0	25 15 ONo: 0 Pos: 0	25 16 ONo: 0 Pos: 0
25 9 ONo: 0 Pos: 0	25 10 ONo: 0 Pos: 0	25 11 ONo: 0 Pos: 0	25 12 ONo: 0 Pos: 0
110 5 ONo: 0 Pos: 0	0 6 ONo: 0 Pos: 0	25 7 ONo: 0 Pos: 0	25 8 ONo: 0 Pos: 0
0 1 ONo: 0 Pos: 0	0 2 ONo: 0 Pos: 0	0 3 ONo: 0 Pos: 0	0 4 ONo: 0 Pos: 0

Shelf 17..32

Position	Description
1	The inventory from shelf 1 to shelf 16 is announced here. Each shelf consist of Part number in the upper middle position Shelf number in the upper right position Order number in the middle position Position number in the lower position
2	Change to inventory of shelf 17-32

**FESTO**  
CP Factory  
ASRS32  
Pallets

## Home - Inventory

Automatic mode 29/04/2021  
MES Mode ■ 10:05:09

Home 
Setup mode 
Parameters 
System

→ Operat. mode

→ Overview

→ Inventory

→ User

→ IO Test

0 29 ONo: 0 Pos: 0	0 30 ONo: 0 Pos: 0	0 31 ONo: 0 Pos: 0	0 32 ONo: 0 Pos: 0
0 25 ONo: 0 Pos: 0	0 26 ONo: 0 Pos: 0	0 27 ONo: 0 Pos: 0	0 28 ONo: 0 Pos: 0
0 21 ONo: 0 Pos: 0	0 22 ONo: 0 Pos: 0	0 23 ONo: 0 Pos: 0	0 24 ONo: 0 Pos: 0
0 17 ONo: 0 Pos: 0	0 18 ONo: 0 Pos: 0	0 19 ONo: 0 Pos: 0	0 20 ONo: 0 Pos: 0

1

---

2

Shelf  
1..16

Position	Description
1	The inventory from shelf 17 to shelf 32 is announced here. Each shelf consist of Part number in the upper middle position Shelf number in the upper right position Order number in the middle position Position number in the lower position
2	Change to inventory of shelf 1-16

**Sub menu user**

Different users can be created here. The function is independent of the selected mode (MES - or default)

The screenshot shows the 'User dialog' screen in the FESTO CP Factory ASRS32 Pallets software. The top navigation bar includes 'Home', 'Setup mode', 'Parameters', and 'System' buttons. The left sidebar contains menu items: 'Operat. mode', 'Overview', 'Inventory', 'User', and 'IO Test'. The main area displays a table of users with columns for User, Password, Group, and Logoff time.

User	Password	Group	Logoff time
Administrator	*****	Administrator group	5
festo	*****	Administrator group	5
PLC User	*****	Unauthorized	5

Display / editing of all users, a login as "Administrator" is required.

**Sub menu I/O Test**

The inputs / outputs are displayed here. The outputs can also be activated in setup mode.

**FESTO**  
CP Factory  
ASRS32  
Pallets

## Home - IO test

Automatic mode 29/04/2021  
MES Mode ■ 10:06:14

**Home**

**Setup mode**

**Parameters**

**System**

Eingänge				Ausgänge			
Byte				Byte			
0	1	2	3	0	1	2	3
0.0	0.0	0.0	0.0	0.0	0.0	0.0	0.0
0.1	0.1	0.1	0.1	0.1	0.1	0.1	0.1
0.2	0.2	0.2	0.2	0.2	0.2	0.2	0.2
0.3	0.3	0.3	0.3	0.3	0.3	0.3	0.3
0.4	0.4	0.4	0.4	0.4	0.4	0.4	0.4
0.5	0.5	0.5	0.5	0.5	0.5	0.5	0.5
0.6	0.6	0.6	0.6	0.6	0.6	0.6	0.6
0.7	0.7	0.7	0.7	0.7	0.7	0.7	0.7

**Enable  
Outputs  
CAUTION  
Program  
return  
of OB1  
No cyclic  
program  
call**

→ Operat. mode

→ Overview

→ Inventory

→ User

→ IO Test

**8.5.6 Main menu - Setup**

See chapter operation mode setup.

**8.5.7 Main menu – Parameter**

**Submenu application**

See chapter operation mode setup.

**Sub menu transitions**

Parameters - Transitions

Automatic mode 29/04/2021  
Default Mode 10:08:49

Home Setup mode Parameters System

No.	Start Condition	execute	Function	Parameter		End condition		
				Partnumber		OK	NOK	
init		<input type="checkbox"/>	0	0	0	0	10	0
1	10	<input checked="" type="checkbox"/>	1	99	0	0	20	0
2	20	<input checked="" type="checkbox"/>	2	99	0	0	30	0
3	0	<input type="checkbox"/>	0	0	0	0	0	0
4	0	<input type="checkbox"/>	0	0	0	0	0	0
5	0	<input type="checkbox"/>	0	0	0	0	0	0
6	0	<input type="checkbox"/>	0	0	0	0	0	0
7	0	<input type="checkbox"/>	0	0	0	0	0	0
8	0	<input type="checkbox"/>	0	0	0	0	0	0
9	0	<input type="checkbox"/>	0	0	0	0	0	0
10	0	<input type="checkbox"/>	0	0	0	0	0	0

If the transitions submenu is selected, the transitions of the mounted application module are displayed. The transitions of all other application modules can be found in the corresponding manuals of the application modules.

5. Click on the gear wheel to access the settings for the transitions. (see the following picture)

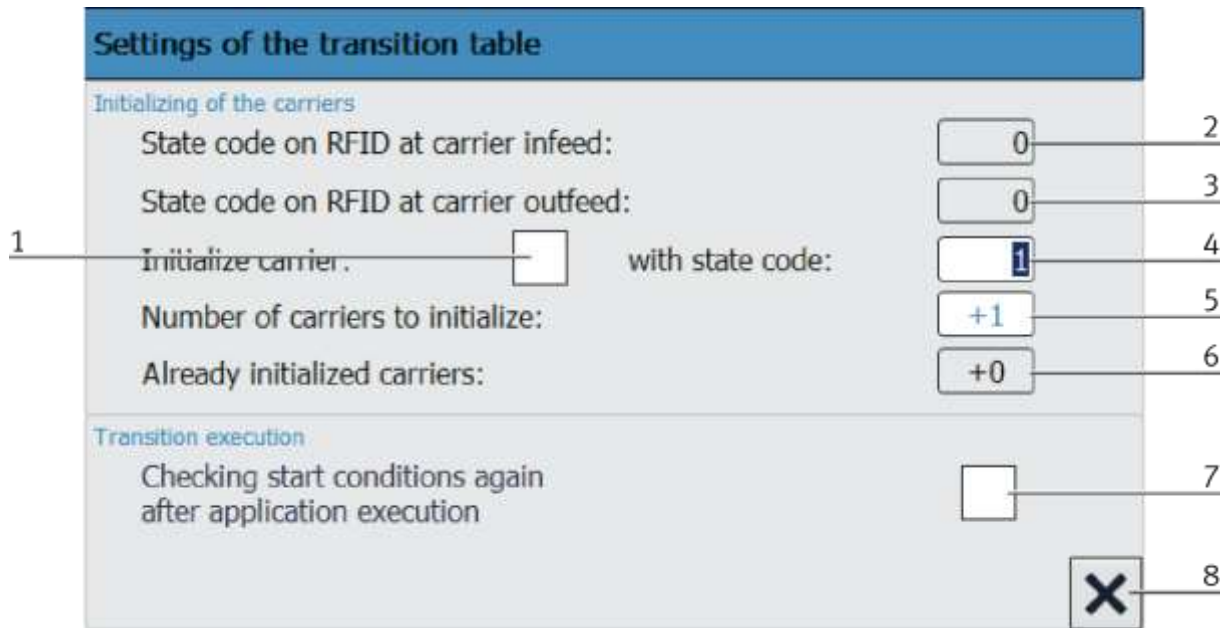

Position number	Description
1	Initialize workpiece carrier: The next carrier arriving at the stopper position is initialized with the end state (state code can be entered under item 4) of the first line of the transition table.
2	Status code on the RFID at carrier infeed: Display of the start condition for application processing
3	Status code on the RFID at carrier outfeed: Display of the start condition after application processing
4	With state code: During initialization (Pos. 1 / Initialize carrier), the carrier is initialized with the state code entered here.
5	Number of carriers to be initialized: Editable, the number of workpiece carriers to be initialized can be entered here.
6	Already initialized carriers: Display of the already initialized workpiece carriers
7	Checking start conditions again after application execution: If this function is activated, the start conditions are checked again after a transition condition has been processed. In this way it is possible to execute an application several times without the carrier leaving the working position.
8	Exit settings



Sub menu belt, stopper

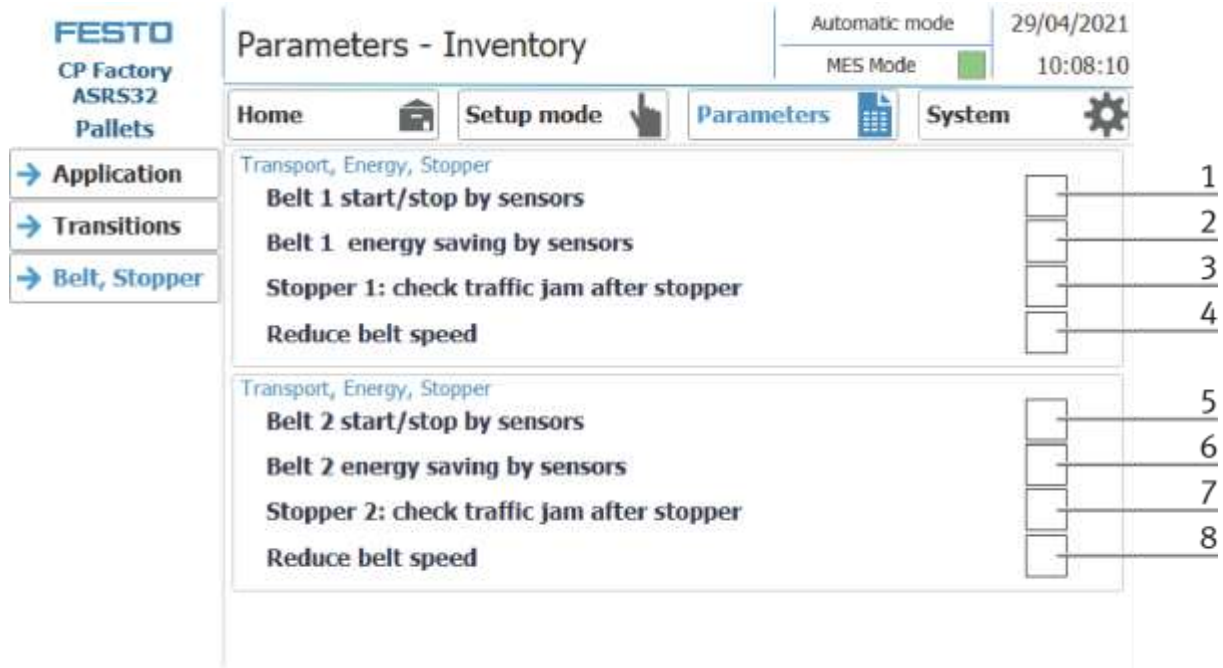

Position number	description
1	Belt 1 Start / Stop by sensors: Hook set when the belt should be switched automatically with the sensors. Switch on when Sensor at belt beginning signals a carrier, switch off when the sensor at the end of the belt signals the carrier passing by
2	Belt 1 energy saving mode with sensors: If no workpiece is detected on the belt via the sensors, the belt is switched off
3	Stopper 1: Check the jam at the belt outlet: The carrier is only released from the stopper if the belt is not occupied at the belt outlet.
4	Reduce belt speed: Here the belt speed is reduced to save energy
5	Belt 2 Start / Stop by sensors: Hook set when the belt should be switched automatically with the sensors. Switch on when Sensor at belt beginning signals a carrier, switch off when the sensor at the end of the belt signals the carrier passing by
6	Belt 2 energy saving mode with sensors: If no workpiece is detected on the belt via the sensors, the belt is switched off
7	Stopper 2: Check the jam at the belt outlet: The carrier is only released from the stopper if the belt is not occupied at the belt outlet.
8	Reduce belt speed: Here the belt speed is reduced to save energy

**FESTO**  
CP Factory  
ASRS32  
Pallets

Conveyor Stop by Sensor / Energy-Mode: conveyor belt instance Drive2 is stopped!

Automatic mode 29/04/2021  
MES Mode ■ 10:08:28

Home

Setup mode

Parameters

System

→ Application

→ Transitions

→ Belt, Stopper

Transport, Energy, Stopper

**Belt 1 start/stop by sensors**

**Belt 1 energy saving by sensors**

**Stopper 1: check traffic jam after stopper**

**Reduce belt speed**

---

Transport, Energy, Stopper

**Belt 2 start/stop by sensors**

**Belt 2 energy saving by sensors**

**Stopper 2: check traffic jam after stopper**

**Reduce belt speed**

If the belt energy saving by sensors function is activated and the belts stop when there are no workpiece carriers on the belt, this is displayed in the upper message window.

## 8.5.8 Main menu – System

### Sub menu - Settings

The screenshot shows the 'System - Settings' interface. At the top right, it displays 'Automatic mode' and the date '29/04/2021', along with 'MES Mode' (indicated by a green square) and the time '10:09:19'. Below this is a navigation bar with buttons for 'Home', 'Setup mode', 'Parameters', and 'System'. The 'System' button is highlighted with a blue gear icon and a '1' with an arrow pointing to it. On the left side, there is a vertical menu with options: 'Settings', 'Diagnostics', 'SW Versions', 'Backup', 'Oper. hours', 'TimeZone PLC', and 'TimeZone HMI'. The 'Settings' option is highlighted with a blue arrow and a '2' with an arrow pointing to it. The main content area is divided into sections: 'HMI view and handling' with buttons for 'Calibrate screen', 'Call cleaning screen', and 'Switch language' (with a UK flag icon); 'HMI system' with buttons for 'Terminate Runtime', 'Transfer', and 'System control'; and 'MES communication' with input fields for 'IP adress' (172.21.0.90), 'Port Query' (2000), 'Port State' (2001), and 'Resource' (14).

1. To get to the system settings, the System button must be selected
2. Click on Settings

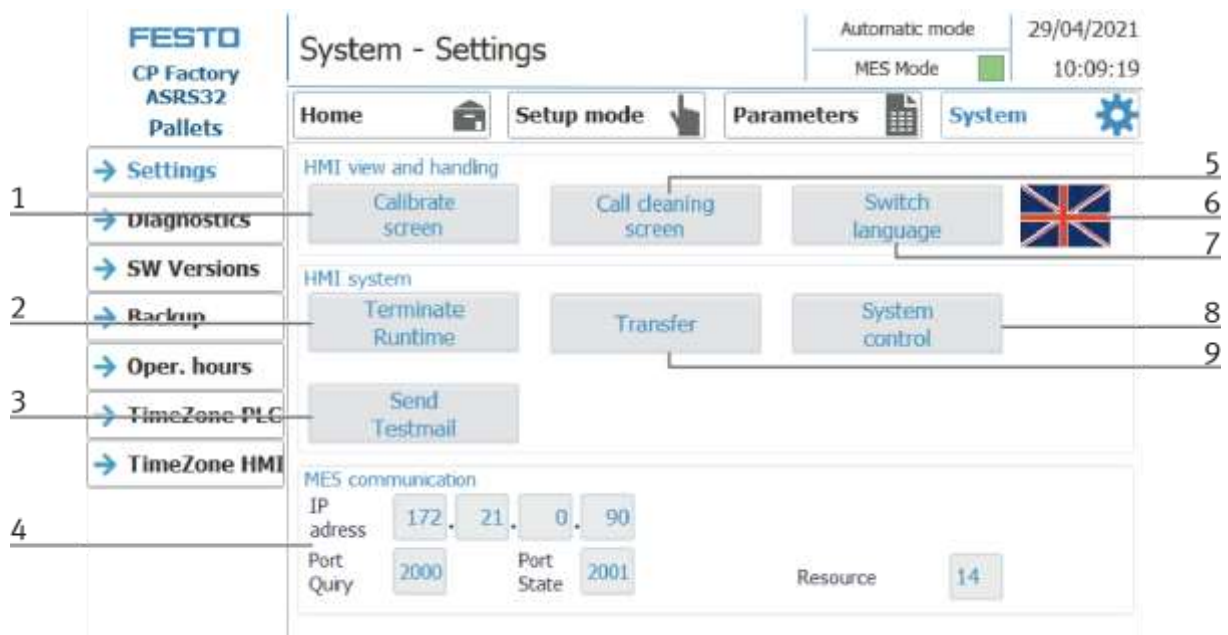

The system can be set in this operating mode.

Position number	Description
1	Button Calibrate Screen - If buttons react inaccurately, calibration of the touch screen can be restored
2	Button Terminate Runtime: The runtime is terminated and returned to Windows.
3	Button send test mail – send test mail to eMailserver (all error messages are sent from the hmi to a eMailserver on the MES4 PC – this function is to test if the configuration is ok.)
4	Display of the MES IP address additionally the IP of the MES can be set here. (Password protected) User: festo, PW: festo) Input fields for your own resource number, query port and status port of the MES connection
5	Button call cleaning screen - the screen can be cleaned here. The touch function is interrupted and unintentional operation is excluded
6	Flag displays only current language. By clicking on button next to the flag language can be switched
7	Button switch language: here the language can be changed
8	Button system control: Windows system control is opened
9	Button Transfer: Runtime is closed and the transfer mode of the HMI is called

Sub menu diagnostics

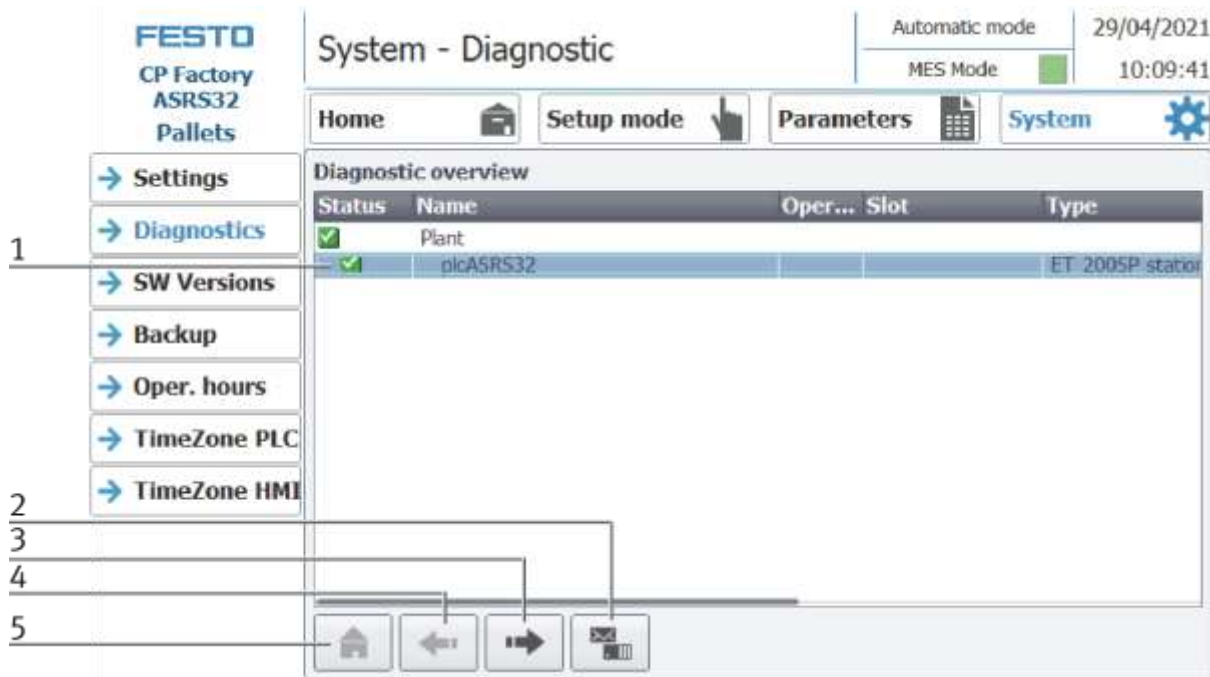

Position number	Description
1	Announcement overview plant
2	Send diagnostic message via mail
3	Next diagnostic message
4	Previous diagnostic message
5	Home Button

### Sub menu software versions

**FESTO**  
CP Factory  
ASRS32  
Pallets

System - Version

Automatic mode 29/04/2021  
MES Mode ■ 10:10:10

Home Setup mode Parameters System

→ Settings  
→ Diagnostics  
→ SW Versions  
→ Backup  
→ Oper. hours  
→ TimeZone PLC  
→ TimeZone HMI

**actual library version:**  
V4.00

Display of the current library version.

**Sub menu Backup**

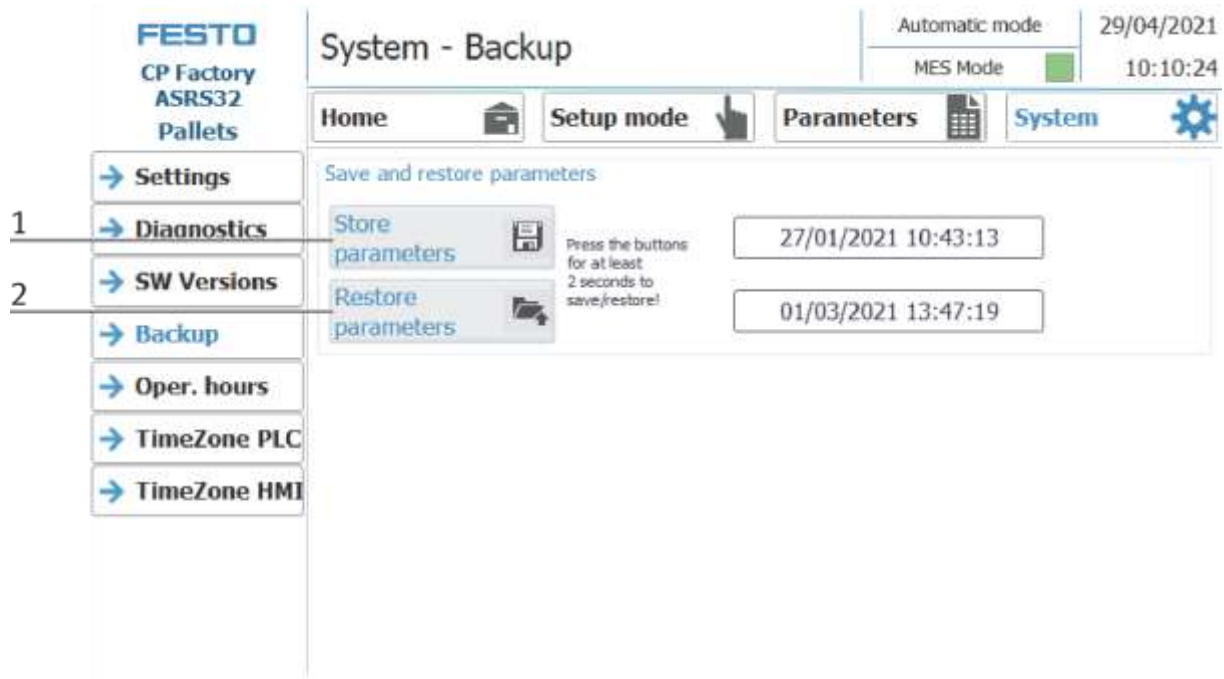

Position number	Description
1	Save parameters button: all parameters are saved, for this it is necessary to press the button for at least 2 seconds. The display shows the date of the last storage.
2	Restore parameters button: all parameters are loaded, for this it is necessary to press the button for at least 2 seconds The display shows the date on which the parameters were last loaded.

**Submenu operating hours counter**

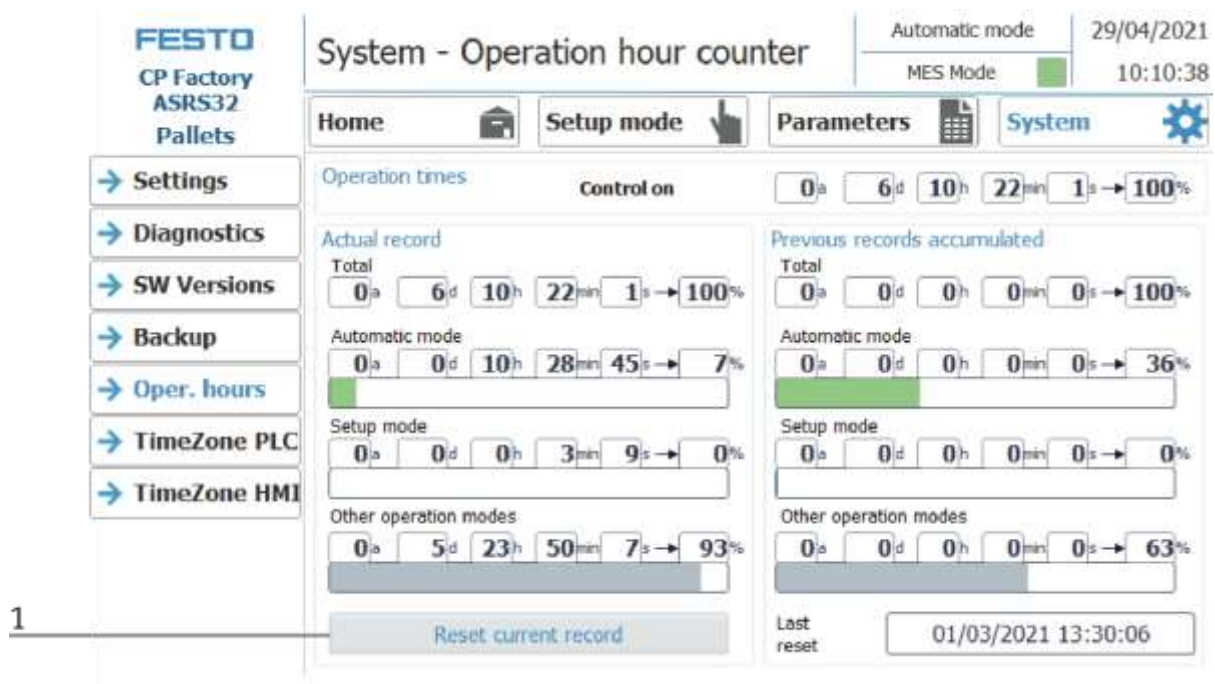

Display of the operating times with allocation to the respective operating mode.

In the "Operation times" area, the time since the control was switched on is counted.

In the "Actual record" area, the time until the next time the "Reset current record" button is pressed is counted. The times are divided into the categories "Total", "Automatic mode", Setup mode and "Other operating modes". The times are counted under the heading "Other operating modes" while the station is in the operating mode "Automatic preselection", "Setup" and "No operating mode". The value in the "Total" line represents the total of the operating times differentiated according to the operating mode. The percentage refers to the proportion of the operating mode in the total time.

With the button (1) "Reset current record", the current recording is set to 0 and the operating times contained therein are added to the "Previous recordings accumulated" area. The current recording can thus be used, for example, for daily recordings.

All counter values are saved in a retentive data block. These are lost when the controller is booted. If they are to be retained, the values must be saved beforehand.



Time zone submenu in the PLC

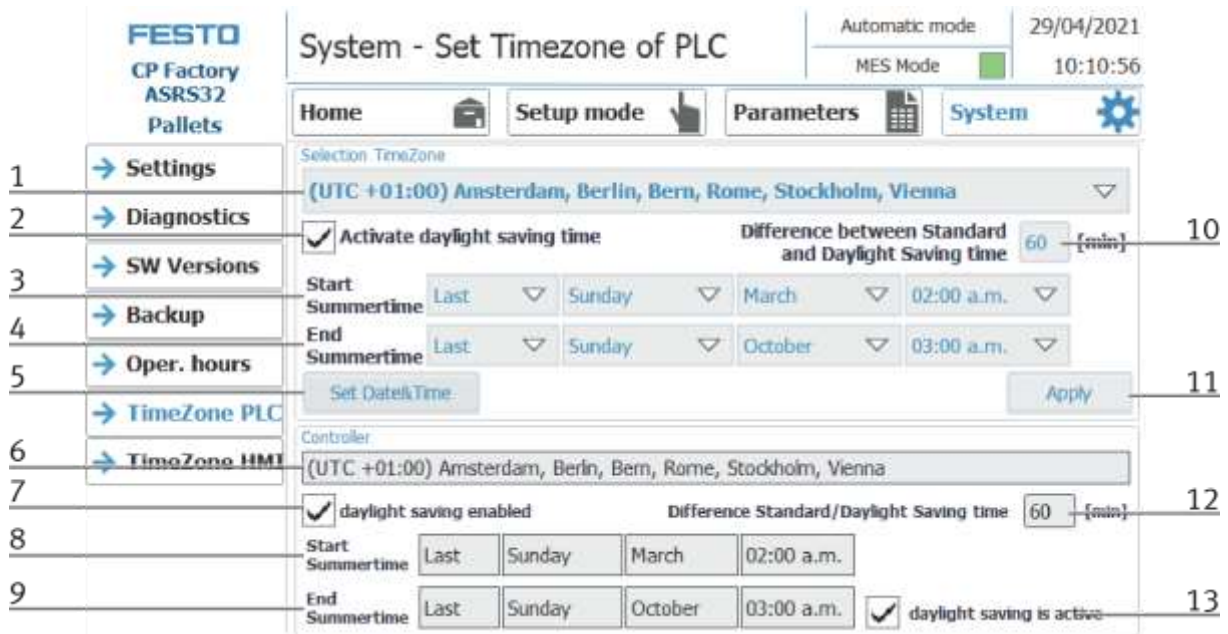

The time and time zone of the PLC can be set in this menu. The default settings of the PLC are overwritten when you click the "Apply" button.

Position number	Description
1	Select TimeZone
2	Checkmark set - the daylight saving time changeover is automatically changed at the times "Beginning of daylight saving time" and "End of daylight saving time" Checkmark not set - there is no daylight saving time changeover
3	Setting the start of daylight saving time
4	Setting the end of summer time
5	Set time & date: When this button is pressed, a pop-up window opens for setting the time of the PLC
6	Display of the current time zone of the controller <i>(Only valid if the time zone of the PLC has been set once using the "Apply" button)</i>
7	Display of whether daylight saving time changeover is active in the PLC. <i>(Only valid if the time zone of the PLC has been set once using the "Apply" button)</i>
8	Display of the current start of daylight saving time in the control <i>(Only valid if the time zone of the PLC has been set once using the "Apply" button)</i>
9	Display of the current end of daylight saving time in the control <i>(Only valid if the time zone of the PLC has been set once using the "Apply" button)</i>
10	Enter the time difference between summer and winter time in minutes.
11	Accept the selected settings for the time zone and time change by pressing the button.
12	Display of the time difference between summer and winter time in minutes. <i>(Only valid if the time zone of the PLC has been set once using the "Apply" button)</i>
13	Display of whether daylight saving time is currently active. <i>(Only valid if the time zone of the PLC has been set once using the "Apply" button)</i>

**Time zone submenu in the HMI**

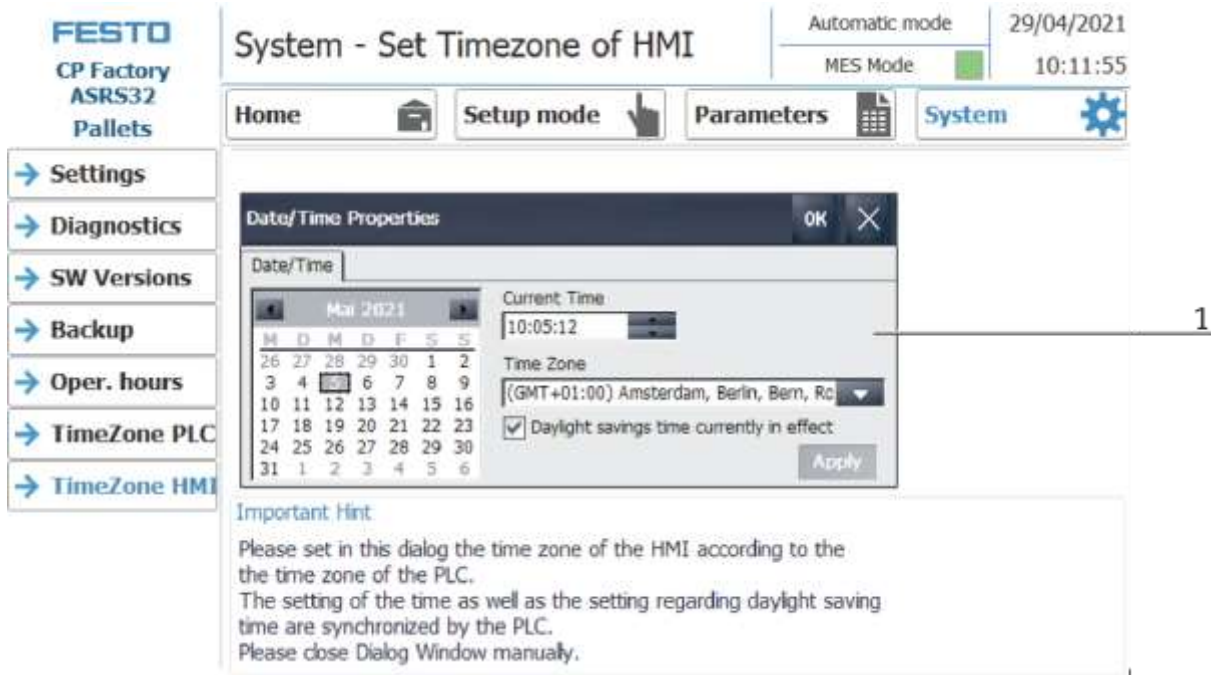

The time and time zone of the HMI can be set in this menu. The default settings of the HMI are overwritten. It is important to set the time zone in the HMI the same as it is set in the PLC, otherwise certain functions will get a different time stamp. (e.g. sending emails)

Position number	Description
1	System pop-up window of the HMI for selecting the time zone. The selected time zone in the Time Zone drop-down field is transferred to the HMI by pressing the "Apply" button. Before exiting the menu item, close the system pop-up window by pressing the X at the top right.



### 8.6 Switching on the station



Illustration similar

1. The station is supplied with voltage.
2. The station is supplied with 6 bar air pressure.
3. All EMERGENCY STOP signal transmitters (pushbuttons, door contacts, light barriers, etc.) are not actuated and unlocked.
4. Turn on the main switch, RESET button is flashing.
5. Press the RESET button, the RESET button goes out, the HMI starts and starts up.
6. Wait till HMI is ready

### 8.6.1 Start automatic

	 <b>WARNING</b>
	<ul style="list-style-type: none"> <li>• <b>Danger of being pulled in at the conveyors</b> <ul style="list-style-type: none"> <li>– When the automatic mode starts, the belts of the conveyor belts start to move, creating a risk of being pulled in.</li> <li>– When starting, do not stand directly at the ends of the belt or hold on to them, keep enough distance.</li> <li>– Failure to heed the information given can lead to injuries.</li> </ul> </li> </ul>

1. Pull out the emergency stop button
2. Press the blue reset button
3. Remove any existing workpieces
4. Acknowledge errors on the HMI by clicking on the error message.

4

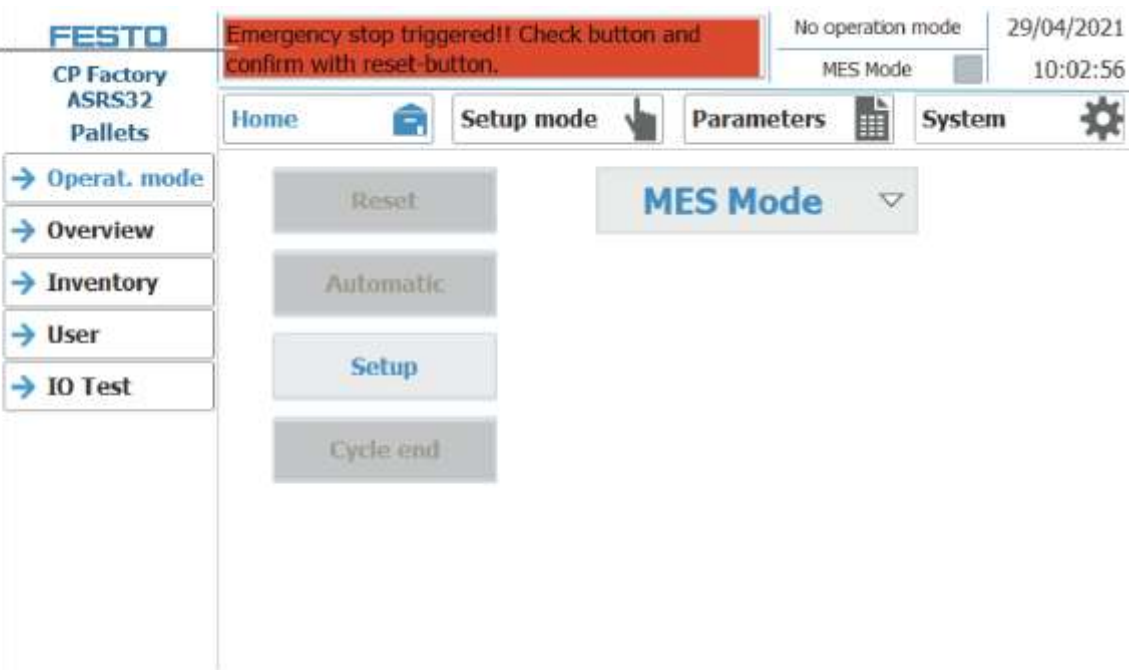

- The error message is displayed in the main window. After the error situation has been remedied, it can be acknowledged by pressing the RESET button.

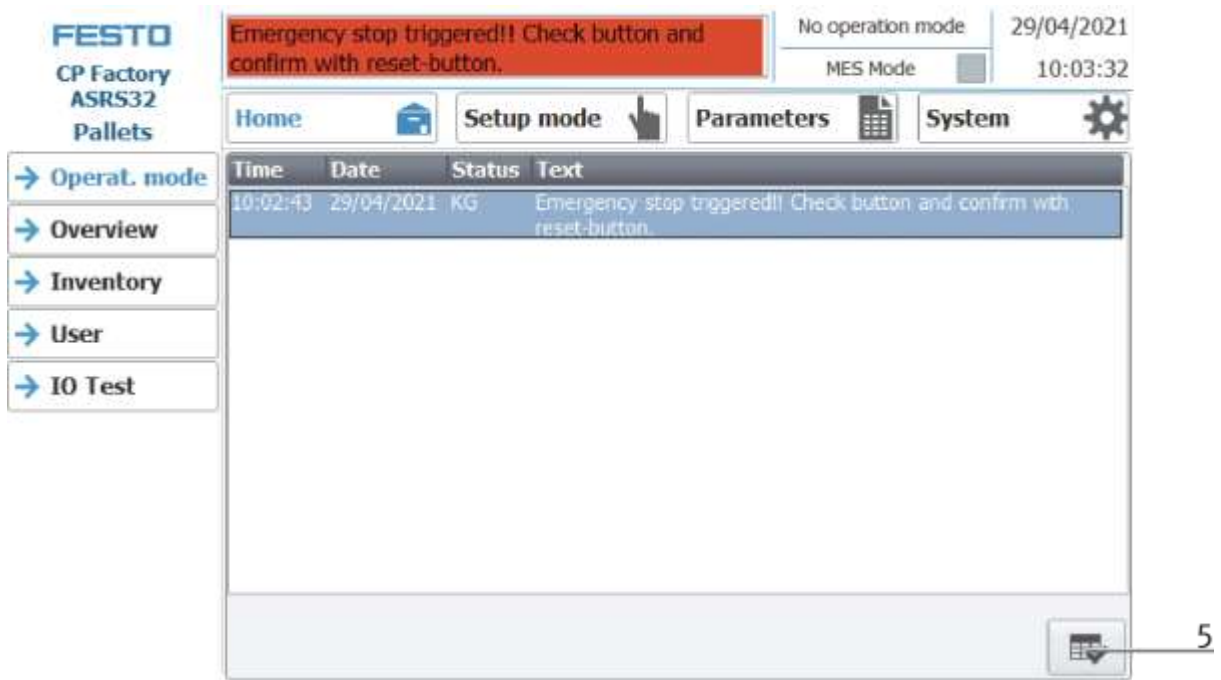

- Press Home Button

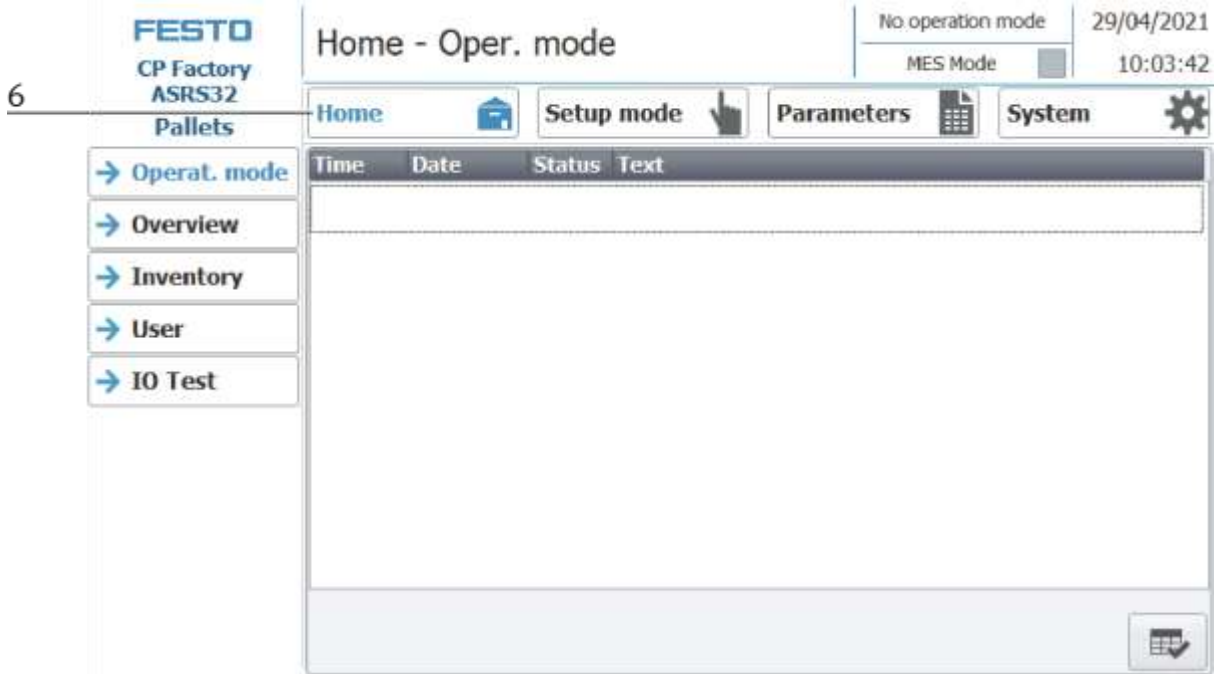

- Press the flashing RESET Button. Station moves in home position.

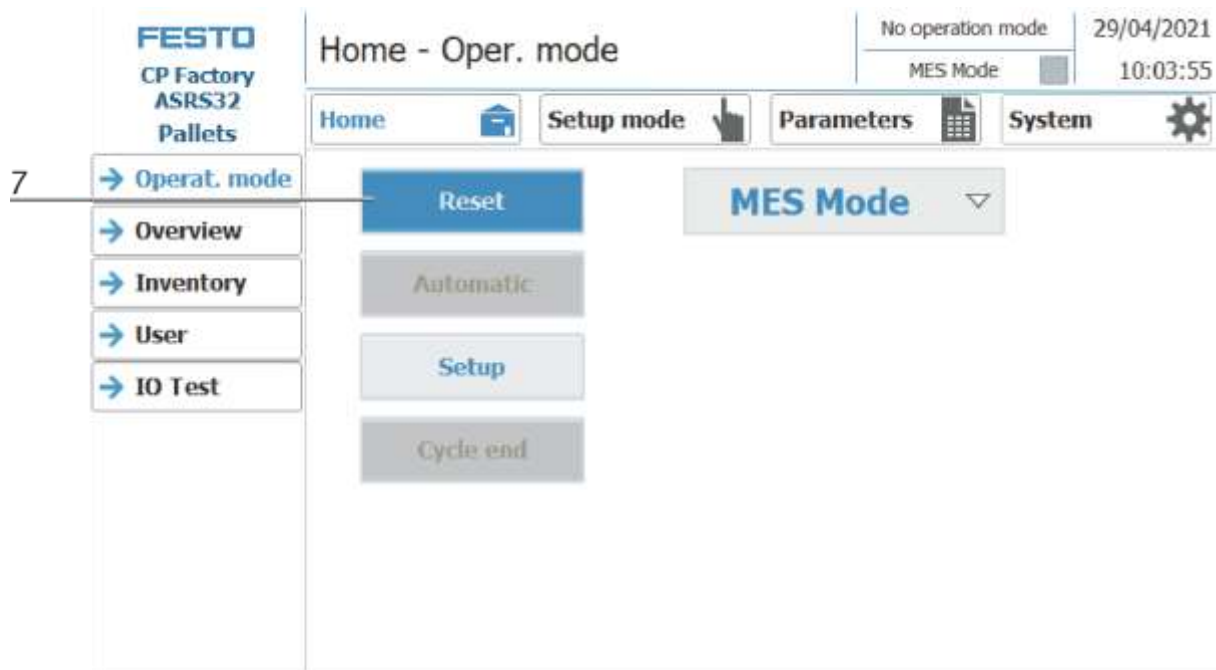

- Press the flashing AUTOMATIC Button

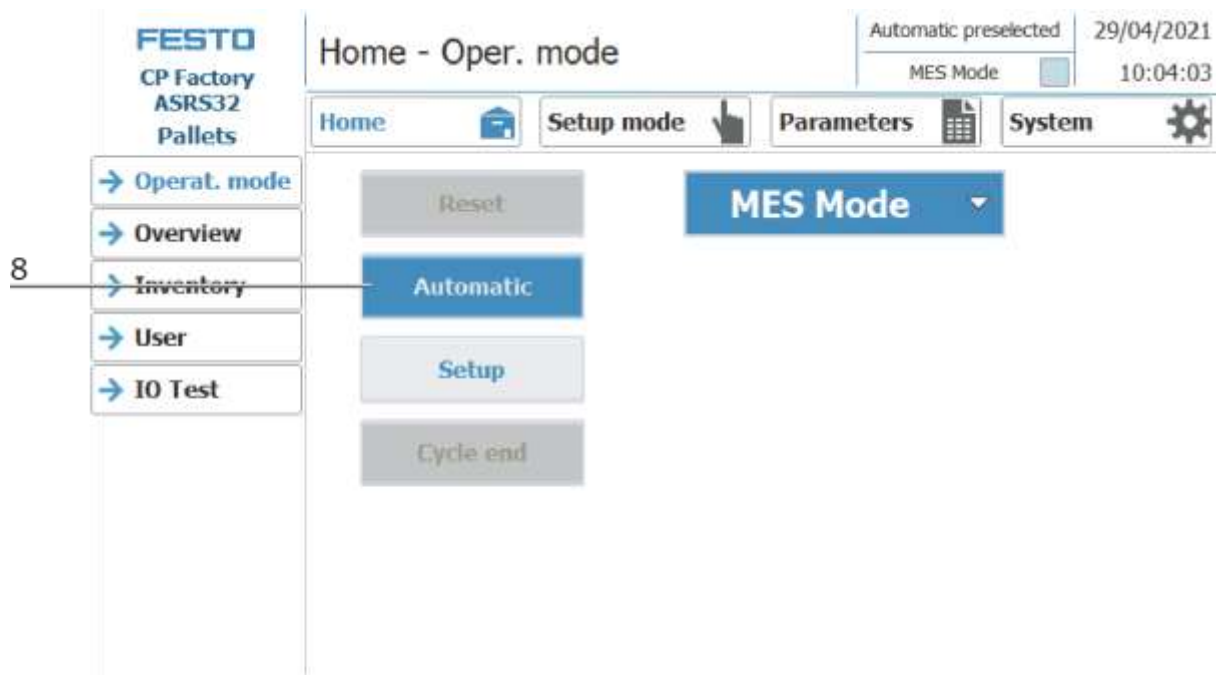

9. AUTOMATIC Button lights up
10. Automatic mode is active

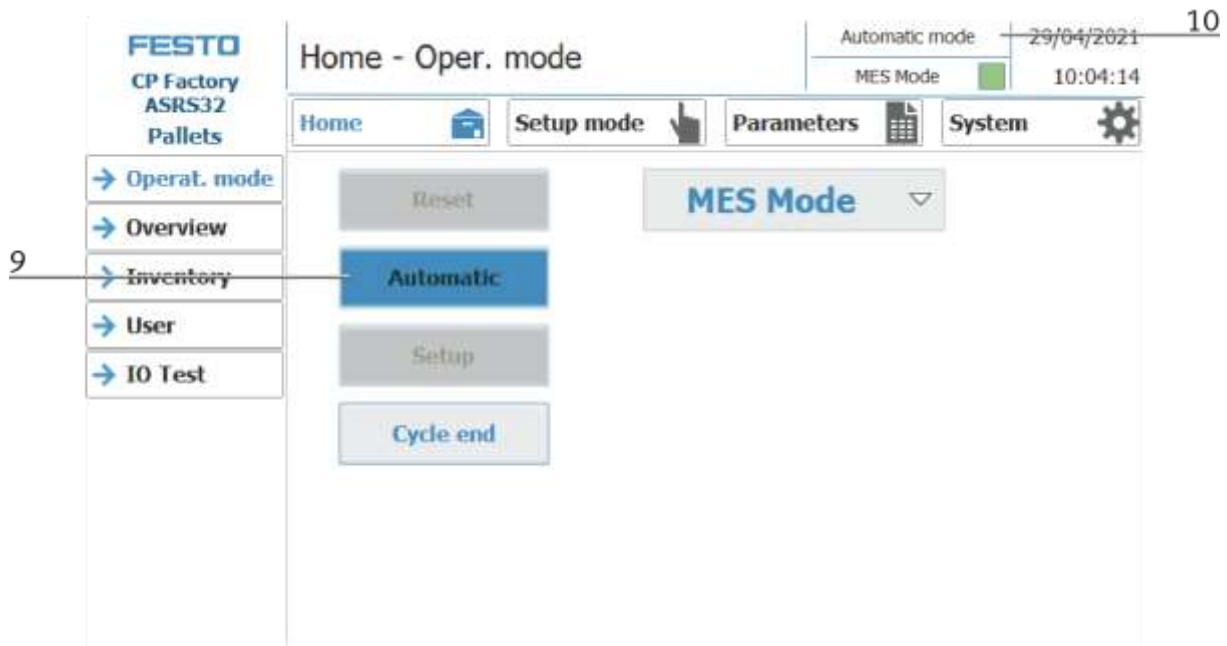

### 8.6.2 Sequence Description Automatic

If the automatic sequence was started,

1. The automatic button lights up blue
2. Stoppers are retracted
3. The workpiece is transported in circulation mode
4. If a carrier moves into the station, this will execute your automatic process. The operation is, however, only started if the operation in MES is intended for this resource and the resource can also carry out this operation.
5. The busy displays become active.
6. During this time, the automatic sequence is executed in the application.
7. The next resource and operation are written to the RFID chip
8. When the module / application module is ready, the display changes back to the original state and the stopper is retracted
9. The carrier moves out of the working position and is available to further modules / application modules.

### 8.6.3 Process description Cycle End

1. An automatic cycle is active.
2. Press the button Cycle End.

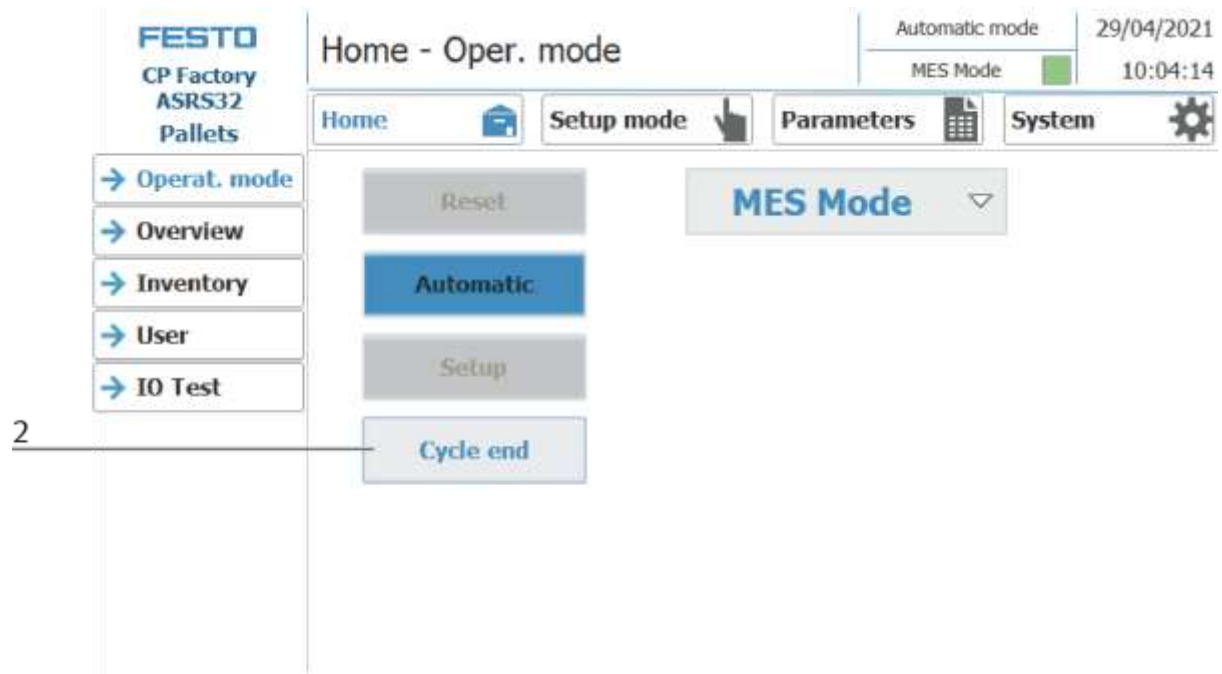

3. The module/application module will execute the run until cycle end. During this time, the button Cycle End has got a red background.
4. The stoppers are extended.
5. The conveyors are stopped.



### 8.7 Manually describe the RFID tag

In order to describe a pallet carrier with a specific ID, or to get information on which data is stored on the pallet carrier, it is possible to read this data or to describe the tag.

For this, it is necessary that a pallet carrier with a functioning tag is at one of the stopper positions and the station is switched on.

The following example is guilty for all read out positions where pallet carriers can be read out.

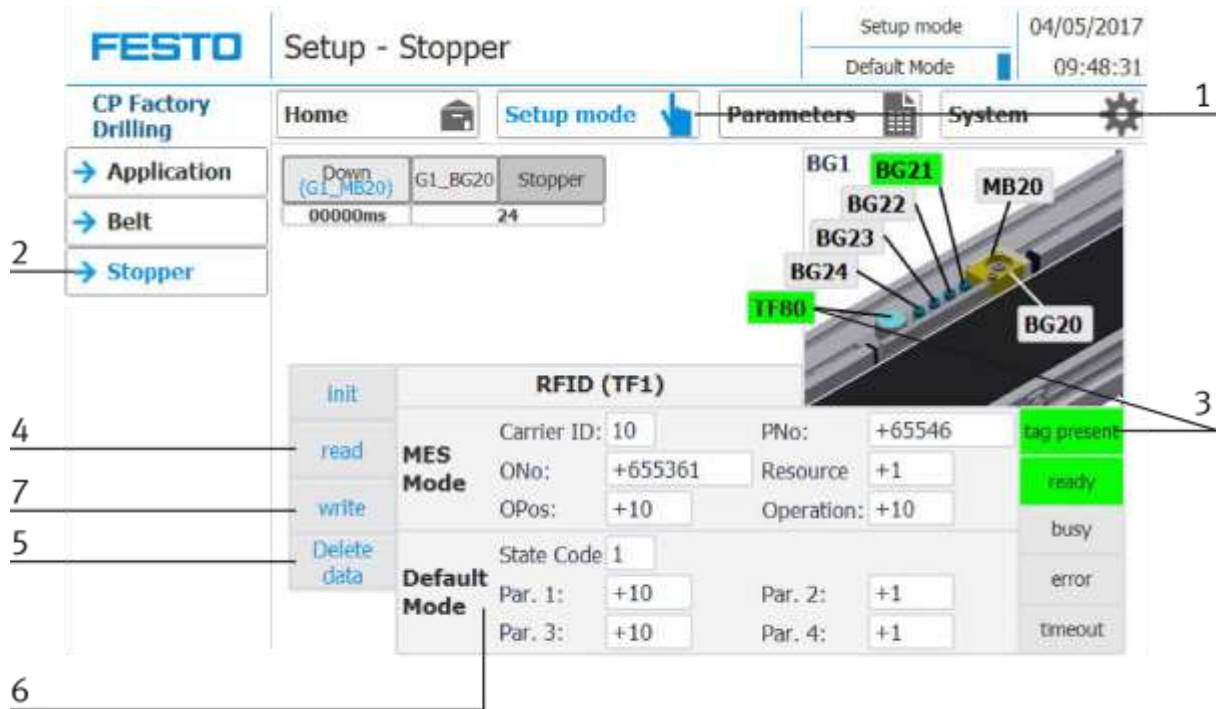

1. Select the Setup mode
2. Select the stopper from the setup menu on the left
3. If an RFID is detected, this is indicated by "tag present". (TF80 and button "tag present" are green)
4. The data of the RFID tag can be read out and displayed by pressing the "read" button.
5. Press the Delete Data button  
For easier input, all data is only deleted in the input mask, the data remains on the tag itself.

6. Enter the desired data in the field (all fields which are white in background can be edited)

**MES Mode**

Carrier ID - displays or enter the carrier number

ONo - the order number is displayed or entered here

OPos - the order position is displayed or entered here

PNo - the part number is displayed or entered here

Resource - here the resource is displayed or entered

Operation - the number of the operation is displayed or entered here

**DefaultMode**

State code - here the state code for the start condition is entered, if these match the transition tables, the parameters are read out and the automatic sequence of the application is started.

Parameter 1 = 1 - Input of the 1 parameter value (e.g., 1 / left side drilling)

Parameter 1 = 2 - Enter the 2 parameter value (e.g., 2 / right side drilling)

Parameter 1 = 3 - Input of the 3 parameter value (e.g., 3 / both sides drilling)

Parameters 2 - 4 - not used in this example

7. Press the "Write" button to write the changes made to the tag.

### 8.7.1 Parameter (ASRS32)

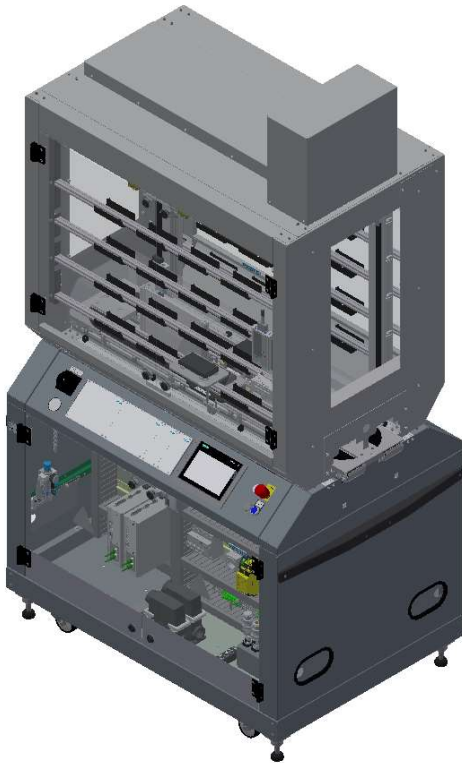



Illustration similar

The following MES operations are available for the ASRS32.

Operation number	Description
210	Store P1: store a part from stopper 1
211	Store P2: store a part from stopper 2
212	Release P1: release a part on stopper 1
213	Release P2: release a part on stopper 2

Operation Number (OpNo):  Short Description:

Description:    

Free Text (Web-Page):

Parameter

No.	Description	Low limit	High limit	Type	Value
1	source	0	0	constant	90
2	target	0	0	on runtime	0
3	part number	0	0	changable	25

Operation Number (OpNo):  Short Description:

Description:    

Free Text (Web-Page):

Parameter

No.	Description	Low limit	High limit	Type	Value
1	source	0	0	constant	91
2	target	0	0	on runtime	0
3	part number	0	0	changable	25

Operation Number (OpNo):  Short Description:

Description:    

Free Text (Web-Page):

Parameter

No.	Description	Low limit	High limit	Type	Value
1	source	0	0	on runtime	0
2	target	0	0	constant	90
3	part number	0	0	changable	25

Operation Number (OpNo):  Short Description:

Description:    

Free Text (Web-Page):

Parameter

No.	Description	Low limit	High limit	Type	Value
1	source	0	0	on runtime	0
2	target	0	0	constant	91
3	part number	0	0	changable	25

**8.7.2 Default parameter (ASRS32)**

Parameter-No.	Description
1	<b>Function</b> 1: store from stopper 1 or stopper 2 2: restore from stopper 1 or stopper 2 11: store form stopper 1 12: restore from stopper 1 21: store from stopper 2 22: restore from stopper 2 Limitation: No limitation of the value in the transition table
2	<b>Part number</b> Limitation: No limitation of the value in the transition table

## 9 Components

### 9.1 Electrical components

#### 9.1.1 2 Quadrant Controller



Illustration similar

#### **Description**

Electronics for DC motors excited by magnet up to about 200 W

The module M-MZ-4-30 is a two-quadrant motor control for DC motors with anti-clockwise and clockwise rotation. It guarantees a safe starting and stopping as well as the control of the rotational direction of motors. In off-state, the load is short-circuited which results in a dynamic braking. By the inlet SLOW, you can switch over from slow speed (adjustment at Tr1) to high speed. At the inlet STOP a limit switch can be installed.

#### **Use:**

Motor controls for brushed motors

Electronic load relay for solenoid valves and various loads

#### **Characteristics**

- Anti-clockwise and clockwise rotation
- Switch-over from high speed to the speed adjusted at the TR.1
- Port for limit switch for stop
- Short-circuit proof and temperature protected
- Limitation for starting circuit

**Technical Data**

Type: M-MZS-4-30

Item No. 06.05.020

Technical Data					
Control circuit	Input A1/A2 A1=Start clockwise A2=Start anticlockwise	Start wave	8	(V)	
		Stop wave	5	(V)	
		Allowed range	0-35	(V)	
	Input A3/A4 A3=slow drive A4=Stop	Shift wave	8	(V)	
		Allowed range	0-35	(V)	
	Adjustment range for turning speed with trimmer at front plate (typical)		0 to max. turning speed		
	Start delay at A1 and A2 to 24V		< 2	(ms)	
Load circle	Nominal voltage (power supply) Ub/range		24 (19-30)	(VDC)	
	Load current/constant load		3/5 depends on switching frequency	(A)	
	Input current at Un /without load circle		T 10 mA	(mA)	
	Loading current I <sub>max</sub> . T=1 sec.		20	(A)	
	Current detection at short		95 Typ. (45-140)	A	
	De-energize time at short		80-400	µs	
Other data	Current entry at stop		<20	(mA)	
	Allowed surrounding temperature		-20 to +40	(C°)	
	DIN VDE-regulations		0110, 0160 in parts		
	Any assembly position / DIN-rail assembly		No / Yes		
	Housing		Plastic housing light grey		
	Dimensions		59x77x50	mm	
	Weight		Approx. 100	G	
	Temperature / short guard		Yes / Yes		
	Connection type screw connection		4mm <sup>2</sup> , 2,5mm <sup>2</sup> Yes		

**Connection diagram**

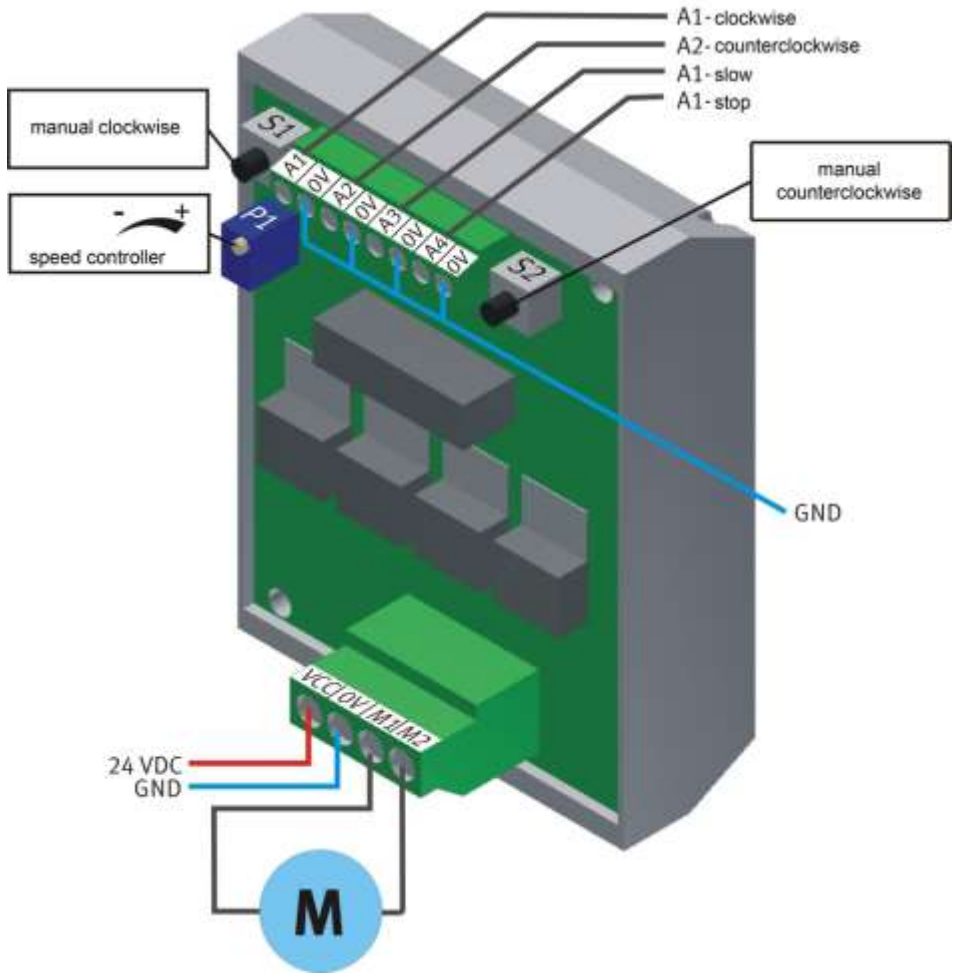

Illustration similar

**Motor MA1 frontside**

Input / Output	Starting Current Limiter	Description
Control - K5-KF10 / Q0.0 / 0x:1	QA1 / X1:re	Conveyor drive 1 clockwise rotation
Control - K5-KF10 / Q0.0 / 0x:2	QA1 / X1:li	Conveyor drive 1 anti-clockwise rotation
Control - K5-KF10 / Q0.0 / 0x:3	QA1 / X1:sl	Conveyor drive 1 creep speed
Conveyor motor DC / -X3M1:4	QA1 / X2:M1	Conveyor motor connection
Conveyor motor DC / -X3M2:3	QA1 / X2:M2	Conveyor motor connection



**Motor MA1 backside**

Input / Output	Starting Current Limiter	Description
Control - K5-KF10 / Q0.4 / 0x:5	QA2 / X1:re	Conveyor drive 2 clockwise rotation
Control - K5-KF10 / Q0.5 / 0x:6	QA2 / X1:li	Conveyor drive 2 anti-clockwise rotation
Control - K5-KF10 / Q0.6 / 0x:7	QA2 / X1:sl	Conveyor drive 2 creep speed
Conveyor motor DC / -X3M1:4	QA2 / X2:M1	Conveyor motor connection
Conveyor motor DC / -X3M2:3	QA2 / X2:M2	Conveyor motor connection

### 9.1.2 Servo Controller

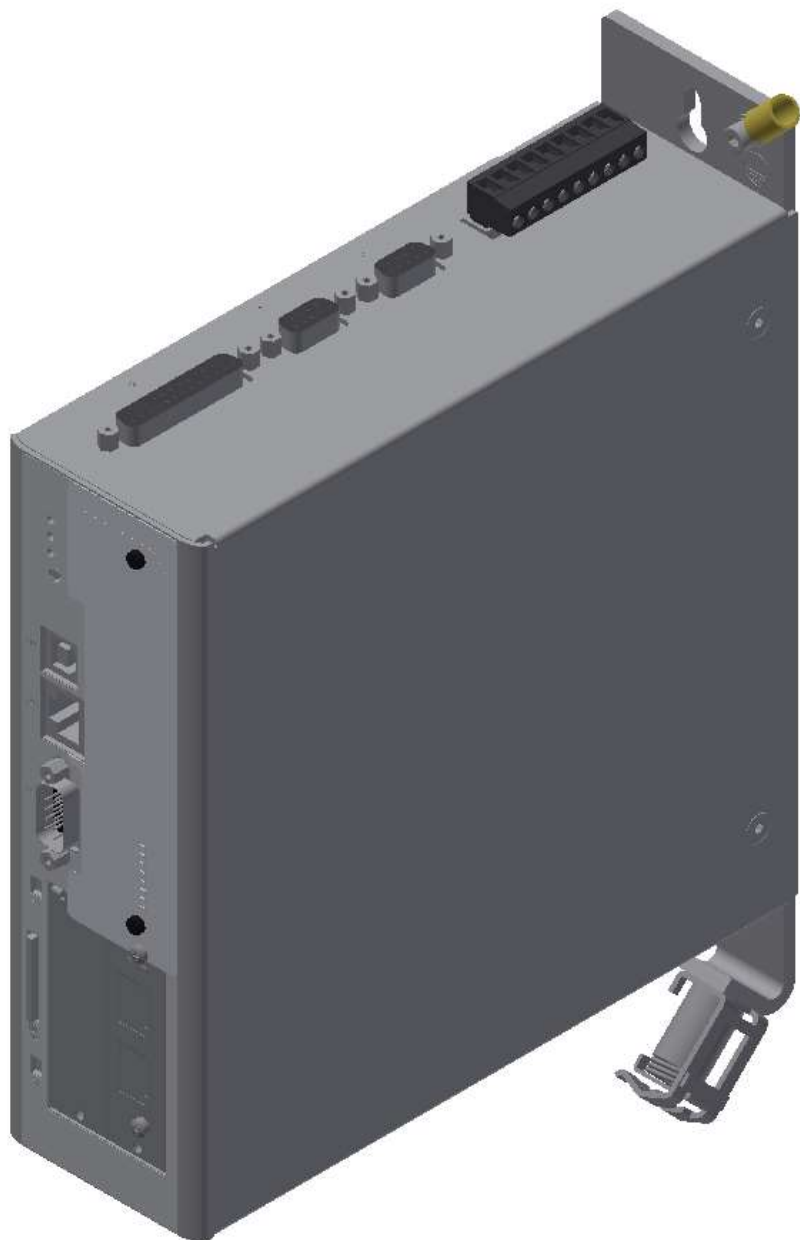

Control unit for axis / illustration similar

Position	Name	
1	Order number	1501325
2	Order number	CMMP-AS-C2-3A-M3

### 9.1.3 Servo motors

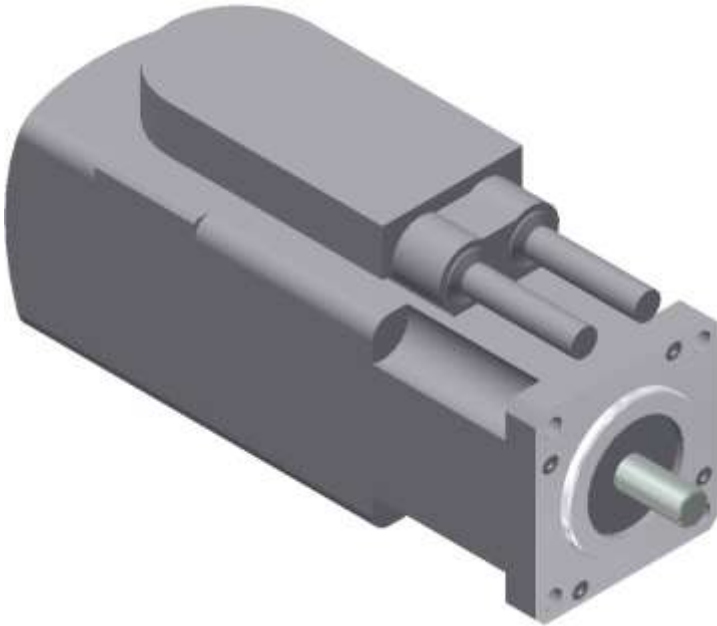

Drive motor Z/X-axis / illustration similar

Drive motors for the Z and X axes are identical. However, the motor for the Z axis is equipped with a brake. A gearbox is mounted upstream of the motor

Position	Name	
1	Order number	550112
2	Order number	EMMS-AS-55-M-LS-TSB

## 9.2 PLC

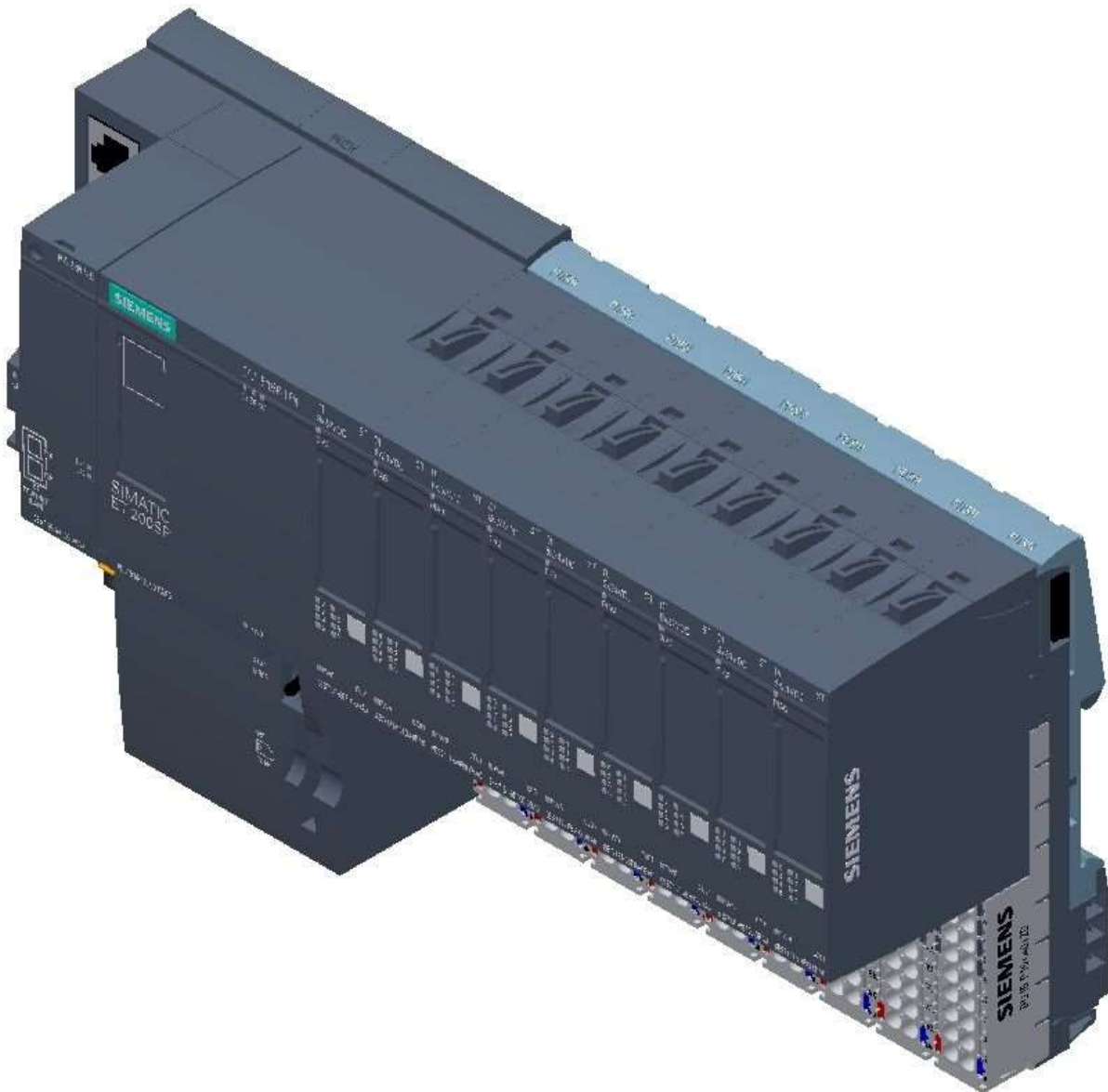

Siemens ET 200 SP / CPU 1512SP F-1PN / illustration similar

For detailed information see electrical circuit diagram.

### 9.2.1 Touch Panel



Siemens TP 700 Comfort / illustration similar

#### Supply voltage

Type of supply voltage	DC
Rated value (DC)	24 V
permissible range, lower limit (DC)	19.2 V
permissible range, upper limit (DC)	28.8 V

#### Input current

Current consumption (rated value)	0.5 A
Starting current inrush $I^2t$	0.5 A <sup>2</sup> ·s

#### Power

Power consumption, typ.	12 W
-------------------------	------

#### Processor

Processor type	X86
----------------	-----

#### Memory

Flash	Yes
RAM	Yes
Memory available for user data	12 Mbyte

### 9.3 Scalance Ethernet Switch



Siemens S7 SPS / illustration similar

The SCALANCE X208 has eight RJ-45 jacks for the connection of end devices or other network segments.

**Product properties**

SCALANCE X-208

Operating Instructions, 12/2011, A5E00349864-19

TP ports / Connector pinout

On the SCALANCE X208, the TP ports are implemented as RJ-45 jacks with MDI-X assignment (Medium Dependent Interface–Autocrossover) of a network component.

RJ-45 jack

Pin number

Assignment

Pin 8 n. c.

Pin 7 n. c.

Pin 6 TD-

Pin 5 n. c.

Pin 4 n. c.

Pin 3 TD+

Pin 2 RD-

Pin 1 RD+

**NOTICE**

TP cords or TP-XP cords with a maximum length of 10 m can be connected to the RJ-45

TP port. With the IE FC cables and IE FC RJ-45 plug 180, an overall cable length of up to 100 m is permitted between two devices depending on the cable type.

**Autonegotiation**

Autonegotiation means the automatic detection of the functionality of the port at the opposite end. Using autonegotiation, repeaters or end devices can detect the functionality available at the port of a partner device allowing automatic configuration of different types of device. With autonegotiation, two components connected to a link segment can exchange parameters and set themselves to match the supported communication functionality.

**Note**

If an IE switch port operating in autonegotiation mode is connected to a partner device that is not operating in autonegotiation mode, the partner device must be set permanently to half duplex mode. If an IE switch port is set permanently to full duplex, the connected partner device must also be set to full duplex. If the autonegotiation function is disabled, the MDI/MDI-X auto crossover function is also inactive. This means it may be necessary to use a crossover cable.

**Note**

The SCALANCE X208 is a plug-and-play device that does not require settings to be made for commissioning.

**MDI / MDIX autocrossover function**

The advantage of the MDI /MDIX autocrossover function is that straight-through cables can be used throughout and crossover Ethernet cables are unnecessary. This prevents malfunctions resulting from mismatching send and receive wires. This makes installation much easier for the user. IE Switches X-200 support the MDI / MDIX autocrossover function.

**NOTICE**

Please note that the direct connection of two ports on the switch or accidental connection over several switches causes an illegal loop. Such a loop can lead to network overload and network failures.

**Auto polarity exchange**

If the pair of receiving cables are incorrectly connected (RD+ and RD- swapped over), the polarity is reversed automatically.



### 9.4 RFID with Ethernet



Turck – TBEN-S2-2RFID-4DXP / 6814029 / illustration similar

#### I/O data mapping

The BLident RFID-a interface modules cannot be controlled by the process data only. In any case, there is a software functional module required in the control. The functional module has been standardized for the RFID systems and is called Proxy Ident Block (PIB).

Input	Byte	Bit 7	Bit 6	Bit 5	Bit 4	Bit 3	Bit 2	Bit 1	Bit 0
Chanel 0	0	Status word channel 0- low byte							
	1	Status word channel 0- high byte							
Chanel 1	2	Status word channel 1- low byte							
	3	Status word channel 1- high byte							

Output	Byte	Bit 7	Bit 6	Bit 5	Bit 4	Bit 3	Bit 2	Bit 1	Bit 0
Chanel 0	0	Control word channel 0- low byte							
	1	Control word channel 0- high byte							
Chanel 1	2	Control word channel 1- low byte							
	3	Control word channel 1- high byte							

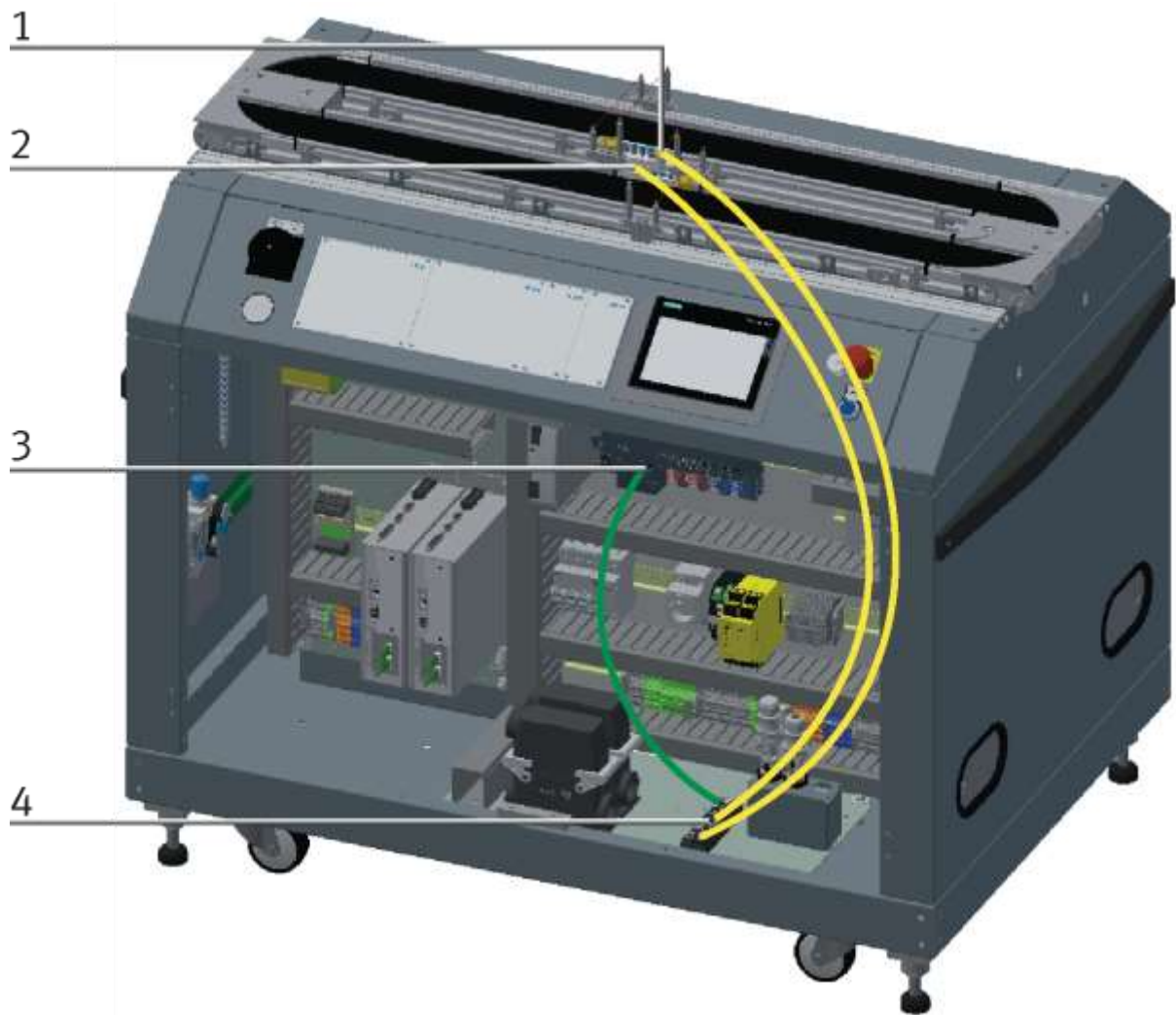

Wiring of the Rfid module to the RFID interface / illustration similar

Pos.	Name
1	Turck read-write head TB-M18-H1147 (equipment identifier G-TF81)
2	Turck read-write head TB-M18-H1147 (equipment identifier G-TF80)
3	Ethernet cable from RFID module KF80 to Turck Switch CU2208
4	Turck Ethernet module with RFID interface (equipment identifier K2-KF80)



RFID read-write head / illustration similar

The Turck RFID read-write head is mounted on the stopper unit on the conveyor. Its designation is TB-M18-H1147.

Name	
Operating voltage	10...30 VDC
DC rated operating current	0-80 mA
Operating voltage	DC
Data transfer	Inductive coupling
Working frequency	13,56 MHz
Read-write distance	max. 30 mm

### 9.4.1 Electronic circuit protection



Murr Mico electronic circuit protection 2-channels / illustration similar

Description	
<b>Input</b>	
Operating voltage	24 V DC (18...30 V DC)
<b>Control inputs</b>	
Input voltage (ON)	10...30 V DC
Impulse length (ON)	min. 20 ms
<b>Control outputs</b>	
Group alarm output	Potential free 30 V AC/DC, 100 mA
<b>General data</b>	
Connection	Spring clamp terminals
Input terminals	1 × 16 mm <sup>2</sup>
Output terminals	Per output 1 × 4 mm <sup>2</sup>
Alarm terminals	2.5 mm <sup>2</sup>
Bridging concept	Two sides, with spring clamp terminals or bridge set (max. 40 A)
Mounting method	DIN-rail mountable TH35 (EN 60715)
Dimensions H×B×T	90×36×80 mm
Temperature range	0...+55 °C (storage temperature -40...+80 °C)
<b>Output</b>	
Current adjustment	1 A, 2 A, 4 A, 6 A, by counters inked rotary switch, sealed
Inrush capacity	max. 20 mF (per channel)

### 9.4.2 Mini Terminal



Multi-pin plug distributor / illustration similar

The multi-pin plug distributor is designed for the inputs and outputs of the station. You can connect PNP sensors and two-pole actuators there. The connection is effected by three-pole M8x1 plugs, and the bus terminal by a 15pole sub-D plug connector. The operating status is displayed on yellow LEDs.

#### **Pin allocation on the multi pin plug distributor**

##### Pin allocation 15pole sub-D plug connector

- Signal lines      Pin 1 to Pin 12
- DC 24V            Pin 13
- 0V                 Pin 14 and Pin 15

##### Pin allocation M8 socket corresponding to IEC 947-5-2

- slots 0 to 11
- Signal line      socket 4
- DC 24V            socket 1
- 0V                 socket 3

## XD20 – Multi pin distributor MPV1

15-pole D-Sub Pin	Bit	Name
1	Bit 0	Stopper 1 down / -BG20
2	Bit 1	Stopper 1 lower / -MB20
3	Bit 2	Pallet available identity sensor 1 / -BG21
4	Bit 3	Reserve
5	Bit 4	Identity sensor 2 / -BG22
6	Bit 5	Reserve
7	Bit 6	Identity sensor 3 / -BG23
8	Bit 7	Reserve
9	Bit 8	Identity sensor 4 / -BG24
10	Bit 9	Reserve
11	Bit 10	Option
12	Bit 11	Reserve / Option station occupied 1
13	+24 V	
14 and 15	0V	

## XD30 – Multi pin distributor MPV2

15-pole D-Sub Pin	Bit	Name
1	Bit 0	Stopper 2 down / -BG30
2	Bit 1	Stopper 2 lower / -MB30
3	Bit 2	Pallet available identity sensor 1 / -BG31
4	Bit 3	Reserve
5	Bit 4	Identity sensor 2 / -BG32
6	Bit 5	Reserve
7	Bit 6	Identity sensor 3 / -BG33
8	Bit 7	Reserve
9	Bit 8	Identity sensor 4 / -BG34
10	Bit 9	Reserve
11	Bit 10	Option / downstream station free 1
12	Bit 11	Reserve / Option station occupied 1
13	+24 V	
14 and 15	0V	

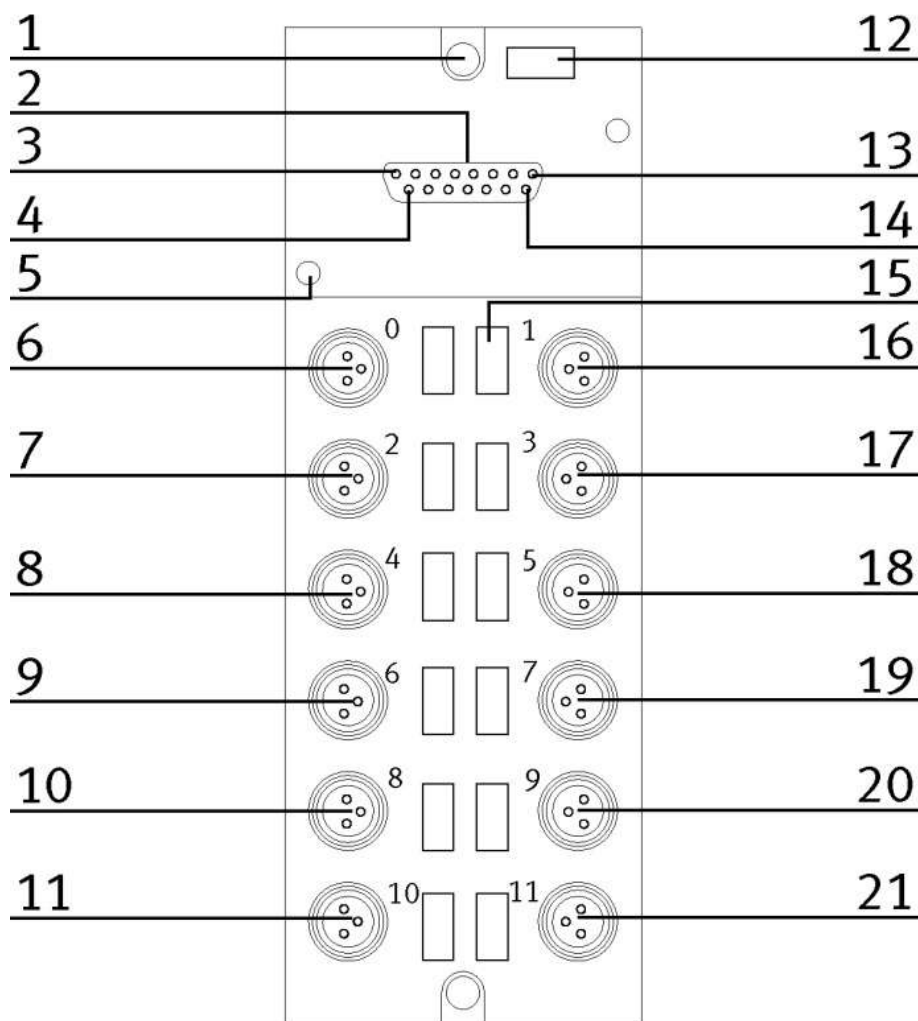

Pos	Designation	Pos	Designation
1	Mounting hole	12	Inscription label
2	15 pole sub-D plug	13	PIN 8
3	PIN 1	14	PIN 15
4	PIN 9	15	Inscription label
5	Mounting hole M3	16	OUT 0
6	IN 0	17	OUT 1
7	IN 1	18	OUT 2
8	IN 2	19	OUT 3
9	IN 3	20	OUT 4
10	IN 4	21	OUT 5
11	IN 5		



9.4.3 SYS link interface

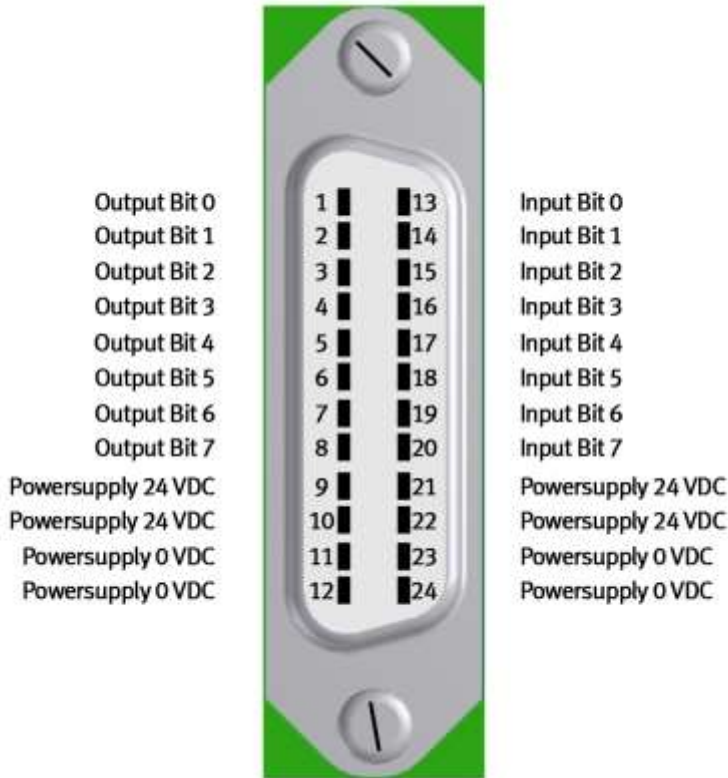

Syslink allocation

SYSlink PIN	Bit	Description	Syslink PIN	Bit	Function
01	0	Output AX.0	13	0	Input EX.0
02	1	Output AX.1	14	1	Input EX.1
03	2	Output AX.2	15	2	Input EX.2
04	3	Output AX.3	16	3	Input EX.3
05	4	Output AX.4	17	4	InputEX.4
06	5	Output AX.5	18	5	Input EX.5
07	6	Output AX.6	19	6	InputEX.6
08	7	Output AX.7	20	7	Input EX.7
09	24V	Power Supply	21	24V	Power Supply
10	24V	Power Supply	22	24V	Power Supply
11	0V	Power Supply	23	0V	Power Supply
12	0V	Power Supply	24	0V	Power Supply

## 9.5 Mechanic components

### 9.5.1 Motor of Conveyor



Motor type 403438 / illustration similar

The motor has got the equipment identifier / 3M1

Name	
Nominal voltage UN /Volt	36
Idling speed n <sub>0</sub> [min <sup>-1</sup> ]	120
Rated torque M <sub>N</sub> [Nm]	2
Starting torque M <sub>A</sub> [Nm]	16
Gear ratio i	53/2
Connection resistance 2 vanes R [m ]	3400
Connection resistance 4 vanes R [m ]	3000
Protection class IP 30	30
Weight [kg]	1

### 9.5.2 The stopper unit

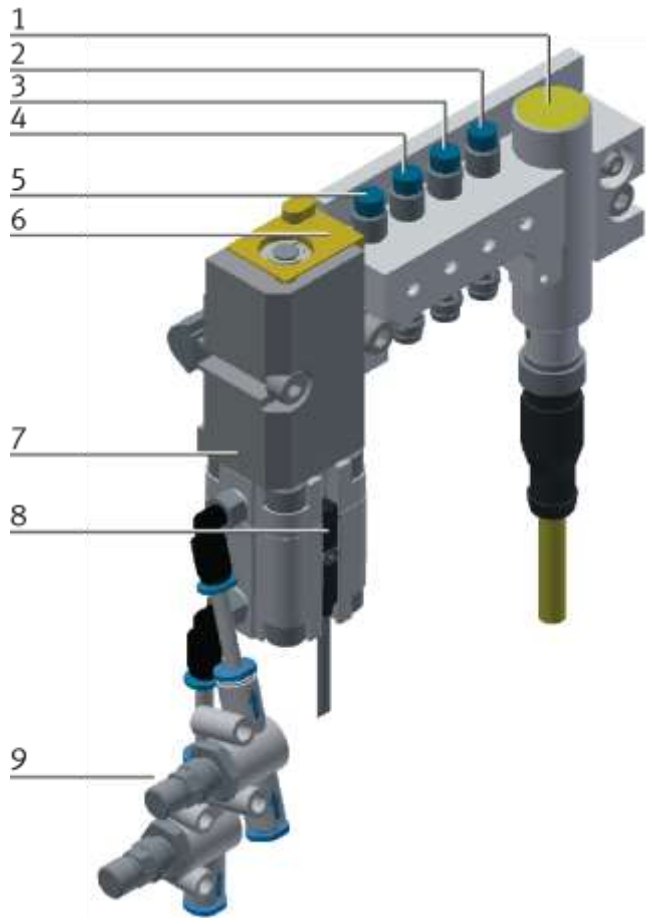

CP Factory Stopper Unit / illustration similar

Position	Description
1	Turck TB-M18-H1147 RFID read-write head
2	Pallet available Ident sensor 1 / Order number 150395 / SIEN-M8NB-PS-S-L
3	Pallet available Ident sensor 2 / Order number 150395 / SIEN-M8NB-PS-S-L
4	Pallet available Ident sensor 3 / Order number 150395 / SIEN-M8NB-PS-S-L
5	Pallet available Ident sensor 4 / Order number 150395 / SIEN-M8NB-PS-S-
6	Stopping unit
7	Stopper cylinder / Order number 157211 / AEVUZ-16-5-P-A
8	Sensor Stopper lowered / Order number 574334 / SMT-8M-A-PS-24V-E-0,3-M8D
9	one-way flow control valve / Order number. 193967 / GR-QS-4

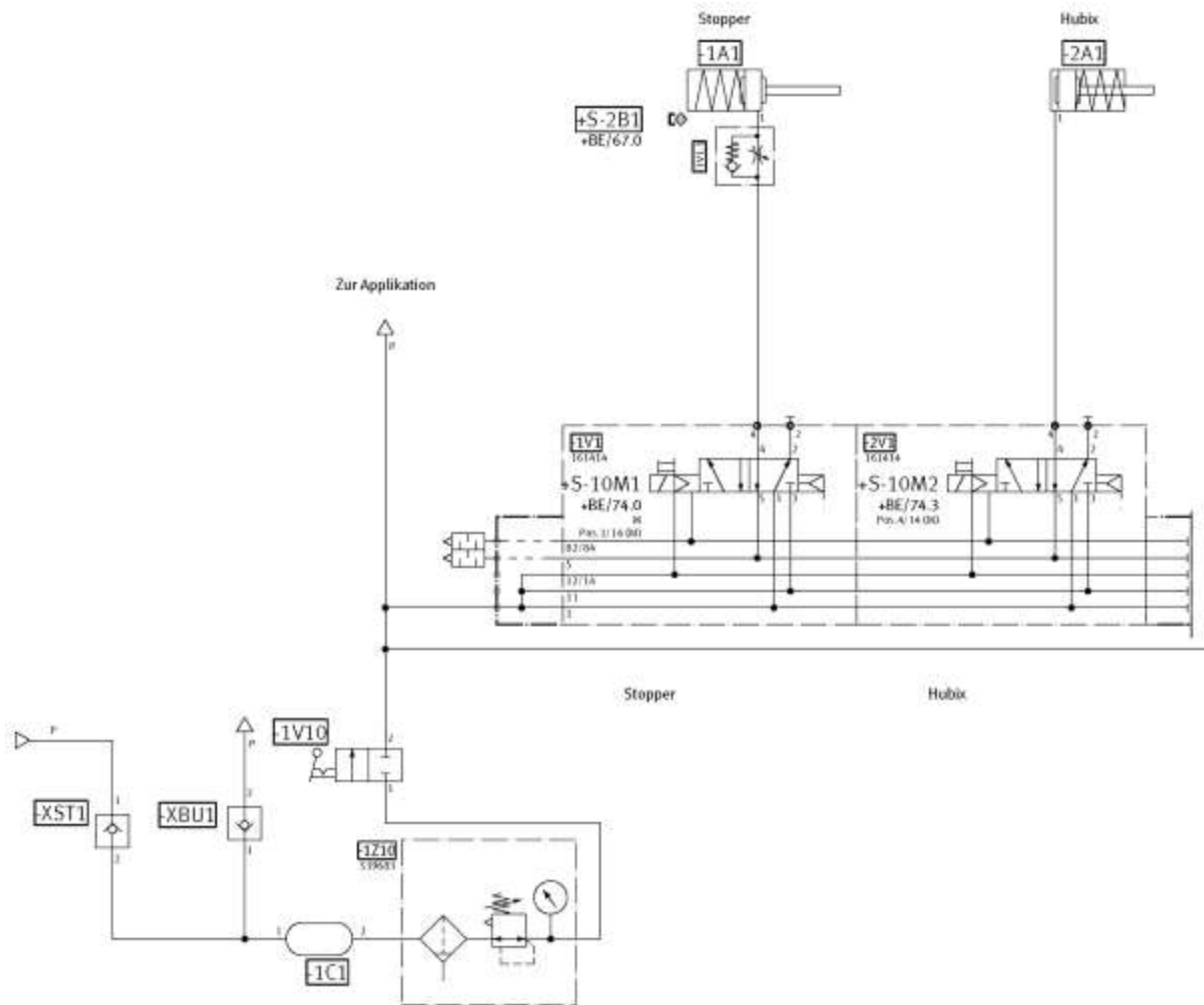
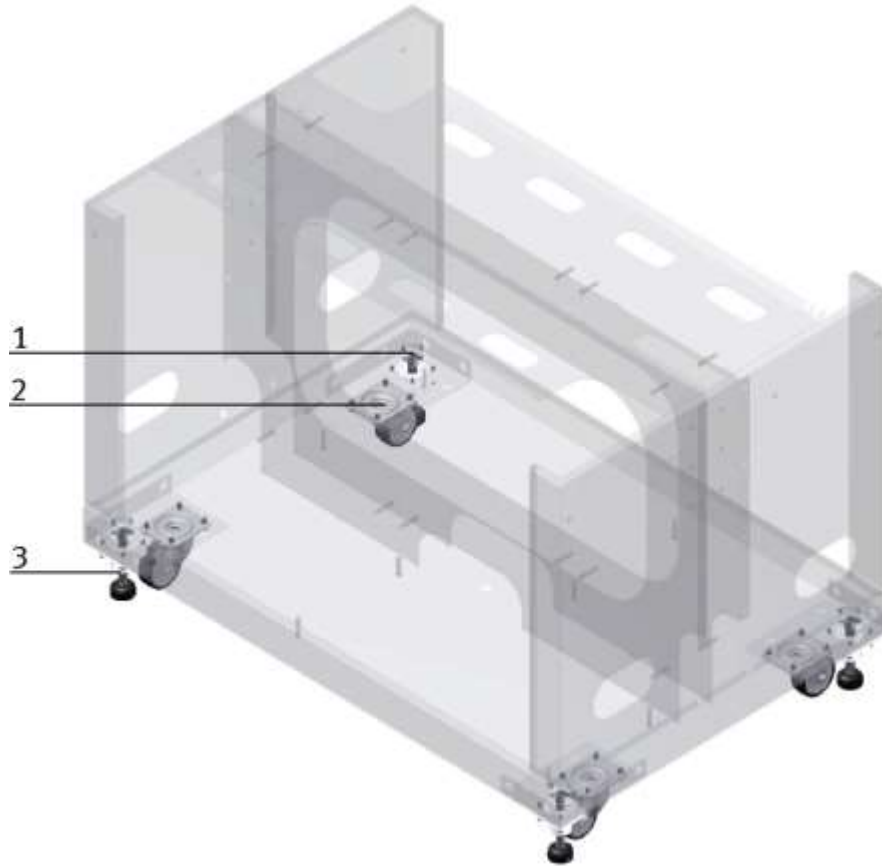

Diagram of pneumatics, Stopper Unit



### 9.5.3 Transportation of the station



CP Factory Transportation method / illustration similar

With the help of mechanically adjustable feet, you can lower the basic module and then put it on the rollers. In this way, an easy transport is possible. If you wind up the machine mounts, you can move the basic module easily to another place.



Position	Description
1	Star knob for adjusting the height of the machine mount
2	Roller
3	Lock nut for locking the machine mount in the position required

	 <b>WARNING</b>
	<ul style="list-style-type: none"> <li>• <b>Danger of crushing for hands/feet</b> <ul style="list-style-type: none"> <li>– It is not permitted to grip onto or under the feet when handling the machine, as there is an increased risk of hands or feet getting crushed or trapped in these areas.</li> <li>– When setting down the station, make sure no persons have their feet under the machine's feet.</li> </ul> </li> </ul>

### 9.5.4 Operation panel working position

So that the components in the base frame of the module are more easily accessible, the entire control panel can be folded up.

The panel is gripped at the bottom and folded up. When the panel is completely raised, the springs stand vertically and support the panel against folding down.

	 <b>WARNING</b>
	<ul style="list-style-type: none"> <li>• <b>Risk of crushing</b> <ul style="list-style-type: none"> <li>– Make sure that the springs are vertical and that the panel is secured against folding down.</li> <li>– It is also important to ensure that no third person can fold the panel down.</li> <li>– Failure to heed the information given can lead to injuries.</li> </ul> </li> </ul>

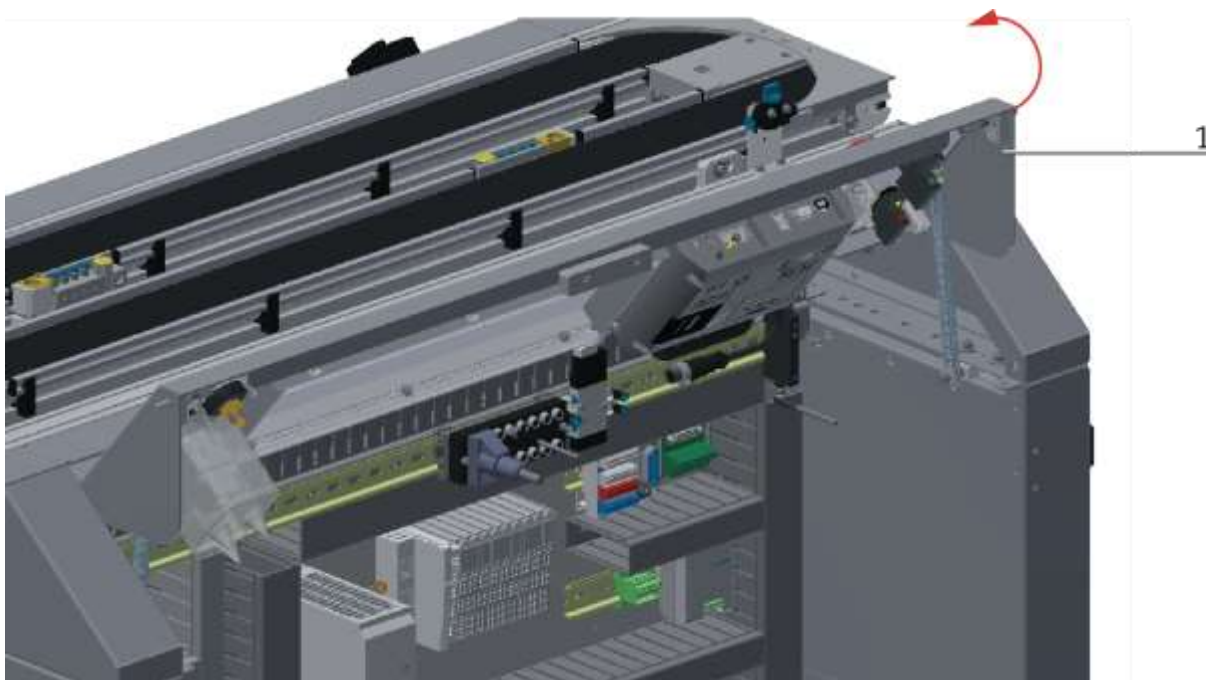

Illustration similar

1. Grip the panel at the bottom and fold it up



Illustration similar

2. Push the springs back in the middle and fold down the control panel

## 10 Message texts and interactive error messages at the HMI

In general, there are three different reporting classes. These are designed as follows

- Message class 0 (displayed red in the message line)
  - the program is immediately stopped and the automatic mode is terminated
  - the cause of the error has to be fixed
  - Then acknowledge the fault and restart the station
- Message class 1 (displayed red in the message line)
  - the program and the automatic mode are stopped at the end of the cycle
  - the cause of the error has to be fixed
  - Then acknowledge the fault and restart the station
- Message class 2 (displayed yellow in the message line)
  - the program and the automatic mode are executed further
  - If the cause of the fault is fixed, the error is automatically acknowledged
- Note
  - Displayed on the HMI but not processed in MES



### 10.1 Message texts

Report class	Location	Alarm name	Report text	Fix error
0	Error	PnErrXaxis	PROFINET Connection to X axis "+ U-K6-KF1" is interrupted.	Please check connection.
0	Error	ErrSchutztuer	Safety door is opened!!	Close the safety doors and activate automatic.
0	Error	PnErrZaxis	PROFINET Connection to Z axis "+ U-K6-KF2" is interrupted. Please check the connection.	Please check connection.
0	Error	ErrXaxis	Error message X-axis is present. Error number: "XXX"	Correct the error and acknowledge the message.
0	Error	ErrZaxis	Error message Z-axis is present. Error number: "XXX"	Correct the error and acknowledge the message.
2	Error	WarnXaxis	Warning X-axis is present. Warning number: "xxx"	Correct the error and acknowledge the message.
2	Error	WarnRfid1Err	RFID reading head 1 (+ G-TF80) Job ended with error.	Check reading head/RFID Chip
2	Error	WarnZaxis	Warning Z-axis is present. Warning number: "xxx"	Correct the error and acknowledge the message.
2	Error	WarnRfid1Tim	RFID reading head 1 (+ G-TF80) Job terminated with timeout.	Check reading head/RFID Chip
2	Error	WarnRfid2Tim	RFID reading head 1 (+ G-TF81) Job terminated with timeout.	Check reading head/RFID Chip
2	Error	WarnRfid2Err	RFID reading head 1 (+ G-TF80) order completed with error.	Check reading head/RFID Chip
2	Error	WarnInit	Home position not possible	Please check Y-axis and gripper.
0	Error	ErrPalet	Wrong orientation of the pallet during storage!	

## 10.2 Interactive error messages

### 10.2.1 Default operation

Interactive messages are displayed via a pop-up window at HMI

The Pop Up has three buttons.

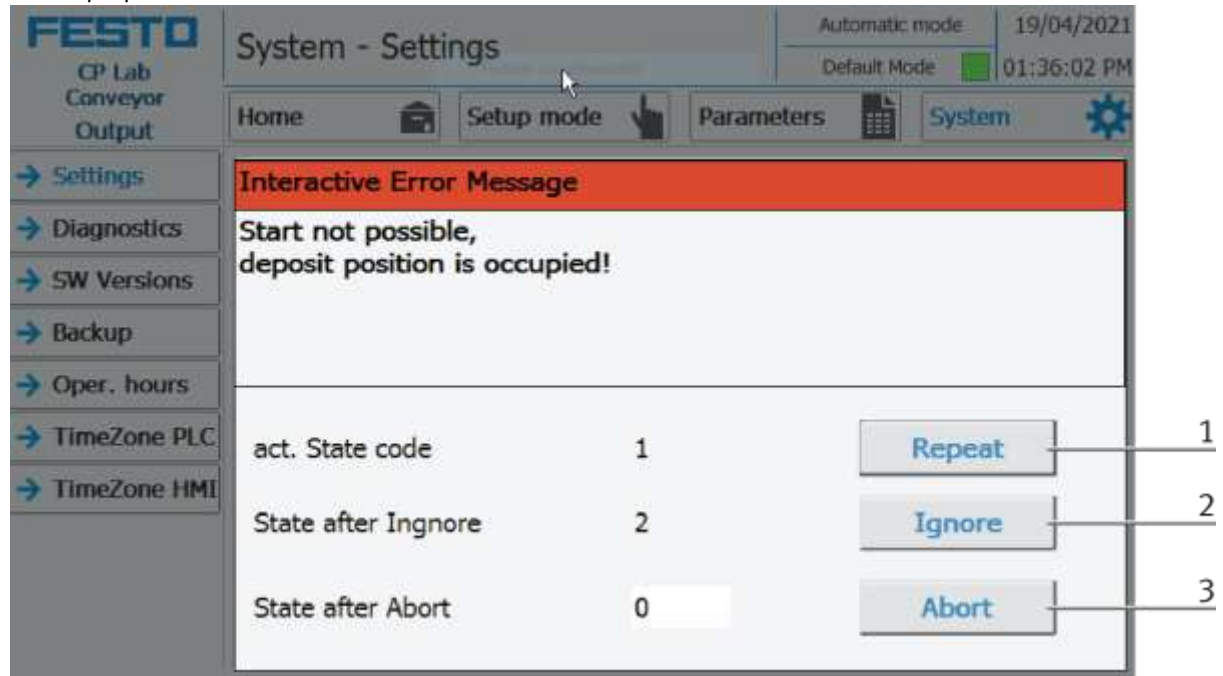

Example application module output - interactive error message in default mode

Position	Note
1	Repeat - An attempt is made to run the application again.
2	Ignore – The error status is ignored; the workpiece carrier receives the status code as indicated in the transition table in the "Initial status" column. The application is no longer executed.
3	Abort – The error status is ignored; the workpiece carrier receives the status code as shown in the input / output field next to the value displayed. This can be changed in this interactive error message window.

### 10.2.2 MES Operation

Interactive messages are displayed via a pop-up window at HMI

The Pop Up has four buttons.



Example application module output - interactive error message in default mode

Position	Note
1	Repeat - An attempt is made to run the application again with the same parameters.
2	Ignore – The application is not executed, but is treated in the MES as if the order step had been executed without errors.
3	Abort – The application is no longer executed. In the MES, this order position is terminated with an error and canceled, depending on whether an error step has been defined or not.
4	Reject order - the application will not be executed. In the MES, the step of this order position is reset and restarted the next time the workpiece carrier arrives.

### 10.2.3 General

Value	Text	Fix error
100	Order aborted with errors!	Start order again

### 10.2.4 ASRS for pallets / ASRS 32

Value	Text	Fix error
1	No pallet on workpiece carrier	Apply pallet
2	Front cover is already available	Remove front cover
3	<p>Parameter 1 – Source position &lt;90 The workpiece carrier is dedicated to an order, but a pallet is not available</p> <p>Parameter 1 – Source position &gt;90 After release procedure there is no pallet at conveyor position</p>	<p>Provide a pallet</p> <p>Check sensor adjustment! (BG54 / BG56)</p>
None	Parameter from order are not guilty, order cannot executed.	Check parameter

## 11 Service and cleaning

The components and systems from Festo Didactic are maintenance-free.

At regular intervals you should have checked:

- the lenses of the optical sensors, fibre optics and reflectors
- the active surface of the proximity switch
- the entire station

can be cleaned with a soft, lint-free cloth or brush.

	<p style="text-align: right;"><b><i>NOTE</i></b></p> <p>Do not use aggressive or abrasive cleaners.</p>
---	---

Protective covers must not be cleaned with alcoholic cleaning agents, there is a risk of embrittlement.

## 12 Further information and updating

Further information and updates on the technical documentation of Festo Didactic components and systems can be found on the Internet at:

[www.ip.festo-didactic.com](http://www.ip.festo-didactic.com)



## 13 Disposal

	<p style="text-align: center;"><b><i>NOTE</i></b></p> <p>Electronic waste contains recyclable materials and must not be disposed of with the domestic waste. Bring electronic waste to a designated municipal collection point.</p>
---	---

**Festo Didactic SE**

Rechbergstraße 3  
73770 Denkendorf  
Germany



+49 711 3467-0



+49 711 34754-88500



[www.festo-didactic.com](http://www.festo-didactic.com)



[did@festo.com](mailto:did@festo.com)