

Schaltungsunterlagen Circuit diagrams

Bezeichnung: CP Applikationsmodul (i)Muskelpresse
 designation: CP application module (i)Muscle press

Kunde:
 Customer:

Anlagenkennzeichen H Muskelpresse
 Plant identifier muscle press

Variante:
 Variant:

Bemerkung: ohne Steuerung
 remark: without Controller

letzte Änderung: 28.11.2019
 last Modification:

Druckdatum: 28.11.2019
 Print date:

Pfad: \\festo.net\DFS01\INT\Data\EPLAN\DATA_27\DE\Projects\Didactic\SC products\26 CP-App-Module\09.
 Path: 03 CP-AM-(i)MPRESS.elk

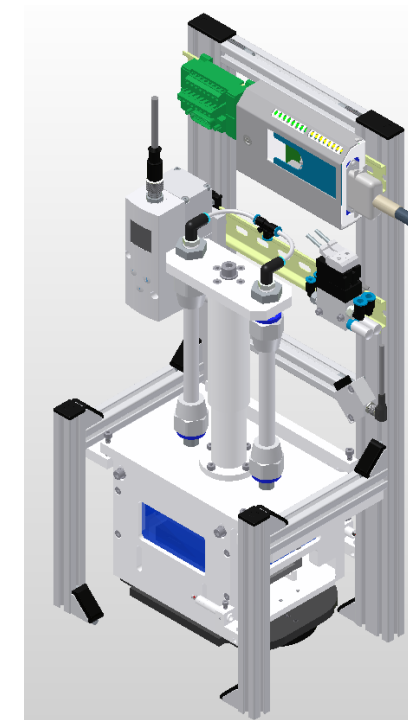

Diese Zeichnung ist Eigentum der Festo Didactic SE This drawing is the property of Festo Didactic SE

Projekteigenschaften project properties

Steuerung Control ohne without

Diese Zeichnung ist Eigentum der Festo Didactic SE This drawing is the property of Festo Didactic SE

Stückliste bill of materials

Bauteil item	Seite Page	Bezeichnung designation	Lieferant supplier	Bestellnummer Order number	Hersteller manufacturer	Eplan-Artikel Eplan Part no.	Menge Quantity	SAP-Nr. SAP-No.	Mechanik
	+HL/14.4	Magnetventil	Festo AG & Co. KG	196927	Festo AG & Co. KG	FES.196927	1		X
-C1	+HL/14.5	Fluidic Muscle	Festo AG & Co. KG	534201	Festo AG & Co. KG	FES.534201	1		
-C2	+HL/14.5	Fluidic Muscle	Festo AG & Co. KG	534201	Festo AG & Co. KG	FES.534201	1		
-RZ1	+HL/14.4	Schalldämpfer	Festo AG & Co. KG	161418	Festo AG & Co. KG	FES.161418	1		X
+HL-BG1	+HL/8.2	Lichtleitergerät mit Stecker	Festo AG	SOEG-L-Q30-P-A-S-2L	Festo AG	165327	1	165327	X
+HL-BG10	+HL/12.8	Miniatur-Druckkraftsensor	Burster	8415	Burster	BUR.8415	1		
+HL-BG10	+HL/7.4	Kraftmessdose	Megatron	KMB19-K-200N-000-D	Megatron	MEG.#KMB19	1	8038607	
+HL-KF10	+HL/12.5	Verstärkermodul	Burster	9243	Burster	BUR.9243	1		
+HL-KF10	+HL/7.4		Megatron	IMA2-DMS	Megatron	MEG.#IMA2-DMS	1	8038606	
+HL-KF11	+HL/12.1	Proportional-Druckregelventil	Festo AG & Co. KG	558337	Festo AG & Co. KG	FES.558337	1		X
+HL-MB1	+HL/10.2	Magnetventil	Festo AG & Co. KG	196915	Festo AG & Co. KG	FES.196915	1	196915	
+HL-W10	+HL/12.1	Steckdosenleitung	Festo AG & Co. KG	525616	Festo AG & Co. KG	FES.525616	1		
+HL-XD1	+HL/8.0	E/A-Terminal neu (mit Gehäuse)	FB-Elektronik		FB-Elektronik	8027412	1	8027412	X
+HL-XD2A	+HL/12.2	Übergabemodul		2962735		PXC.2962735	1	526213	

Diese Zeichnung ist Eigentum der Festo Didactic SE This drawing is the property of Festo Didactic SE

<<5

+HL/7>>

Datum	17.09.2018	FESTO Artikelstückliste : FES.196927 - PXC.2962735 Item parts list : FES.196927 - PXC.2962735	S-Nr.	
Bearb.	Schuhmacher		PSP / DPJ	VN
Erst.	Schuhmacher		= H	Muskelpresse
Ze.Nr.	V3436.E10		+ INFO	Info
Festo Didactic SE Reichbergstraße 3 D-73770 Denkendorf				Seite 6 von

N: F:FDMS10DE E:PL0VZFG7M \\festo.net\DFS01\INT1\Data\EPLAN\DATA_27\DE\Projects\Didactic\SC_products\26 C2 App Module\09.03 CP-AM-()MPRESS.elk

Diese Zeichnung ist Eigentum der Festo Didactic SE. This drawing is the property of Festo Didactic SE.

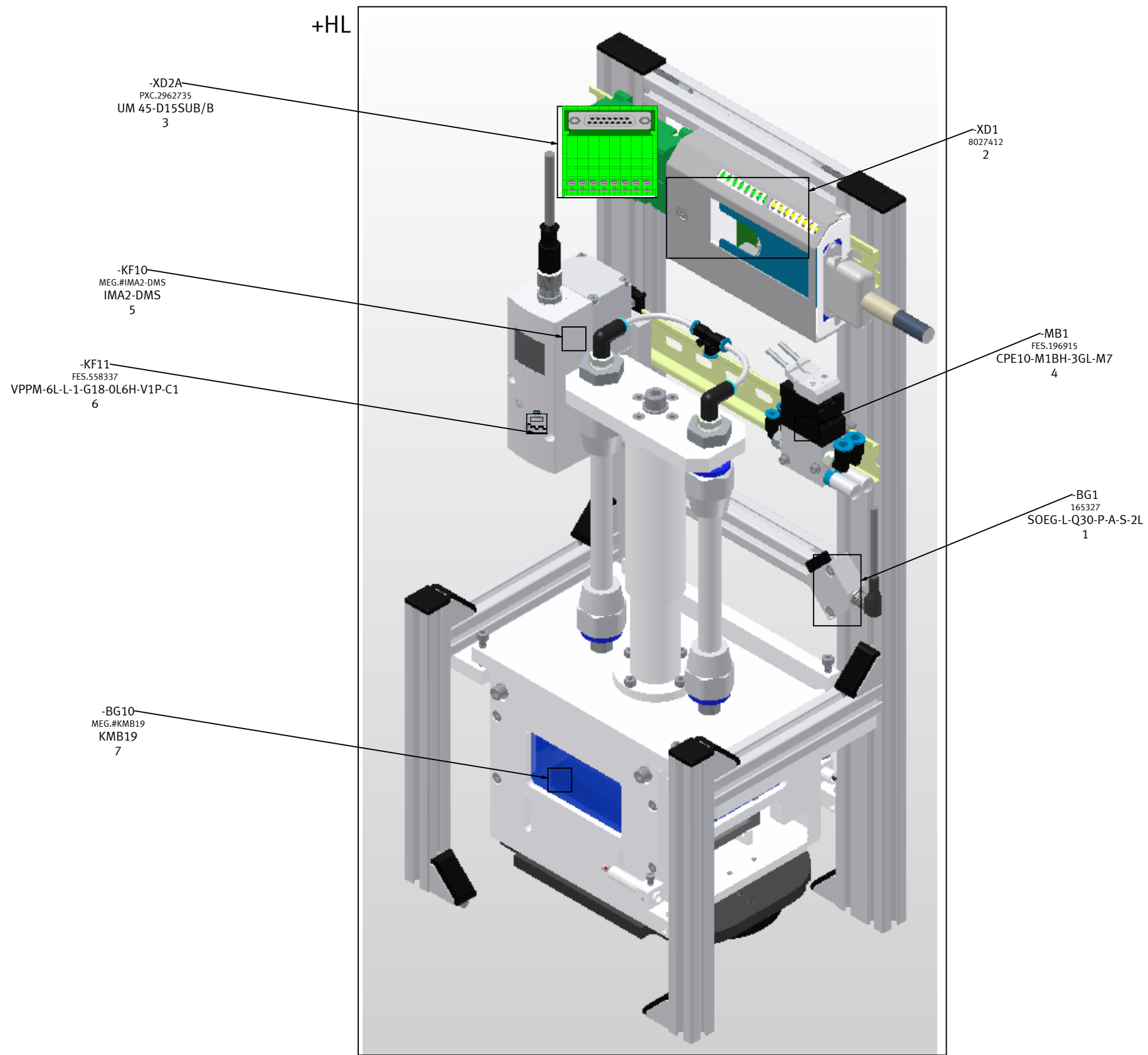

<<+INFO/6

8>>

Datum	17.09.2018	Festo Didactic SE
Bearb.	Schuhmacher	Rechbergstraße 3
Erst.	Schuhmacher	D-73770 Denkendorf
Ze.Nr.	V3436.E10	



Aufbauplan assembly

S-Nr.			
PSP / DPJ	VN	= H	Muskelpresse
		+ HL	Muskelpresse
			Seite 7 von

Diese Zeichnung ist Eigentum der Festo Didactic SE This drawing is the property of Festo Didactic SE

-XD1
/8.0
E/A-Modul Station
In/Out-Module Station

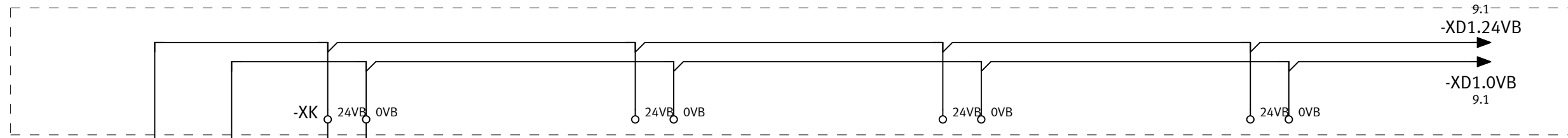

-XD1
E/A-Modul Station
In/Out-Module Station

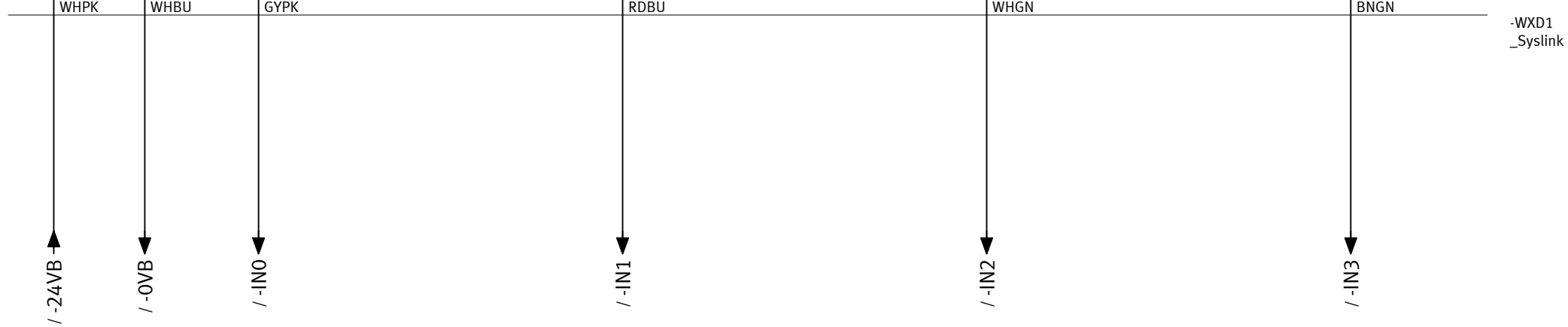

Werkstück
vorhanden

workpiece
available

Reserve
Reserve

Reserve
Reserve

Reserve
Reserve

<<7

9>>

Datum	17.09.2018
Bearb.	Schuhmacher
Erst.	Schuhmacher
Ze.Nr.	V3436.E10

Festo Didactic SE	
Rechbergstraße 3	
D-73770 Denkendorf	
N:	
F:	
EPL0VZFG7M	\\Festo.net\DFS01\INT1\Data\EPLAN\DATA_27\DE\Projects\Didactic\SC products\26 CP2\app



Eingänge
inputs

S-Nr.	
PSP / DPJ	VN

= H	Muskelpresse	Seite 8
+ HL	Muskelpresse	von

-XD1
/8.0
E/A-Modul Station
In/Out-Module Station

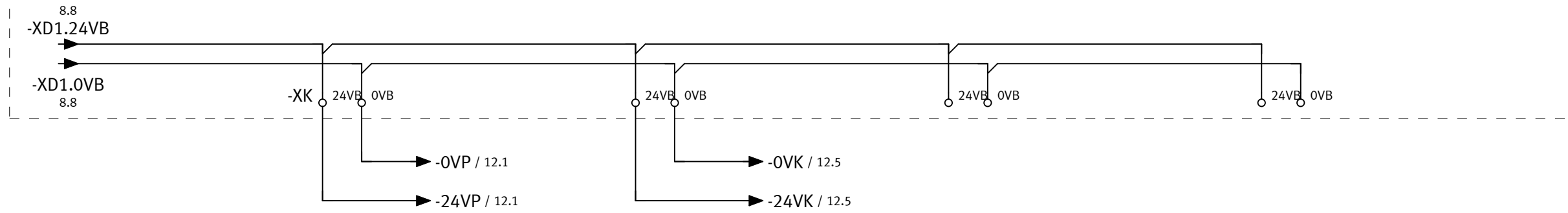

-XD1
E/A-Modul Station
In/Out-Module Station

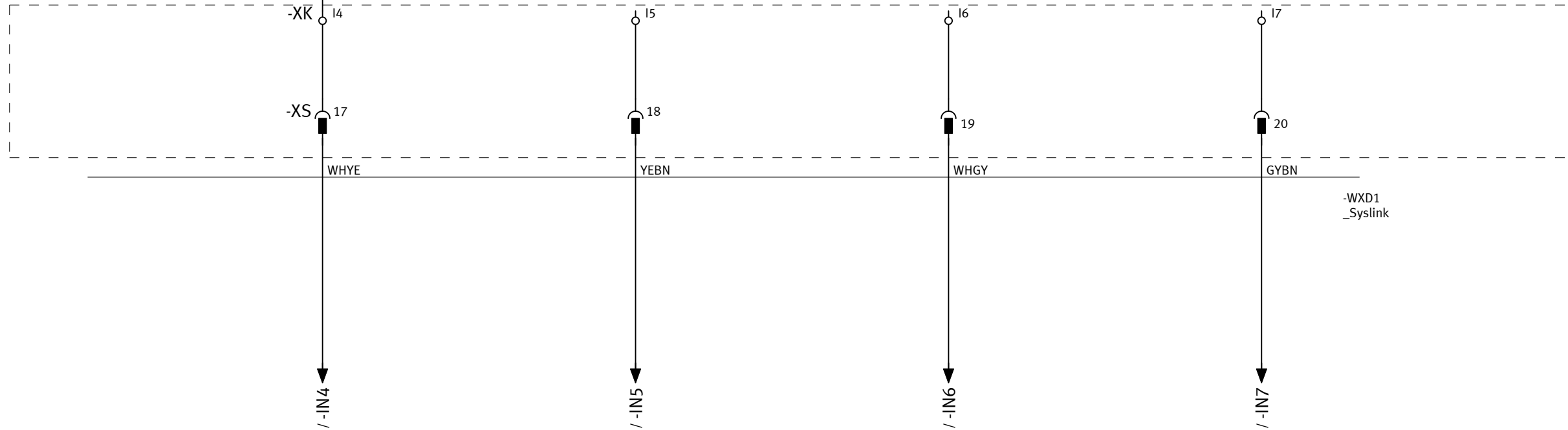

Druckregler Druck erreicht
Pressure regulator reached print

Reserve
Reserve

Reserve
Reserve

Reserve
Reserve

Datum	17.09.2018	Festo Didactic SE	
Bearb.	Schuhmacher	Rechbergstraße 3	
Erst.	Schuhmacher	D-73770 Denkendorf	
Ze.Nr.	V3436.E10	N:	F:



Eingänge
inputs

S-Nr.			
PSP / DPJ	VN	= H	Muskelpresse
		+ HL	Muskelpresse
			Seite 9 von

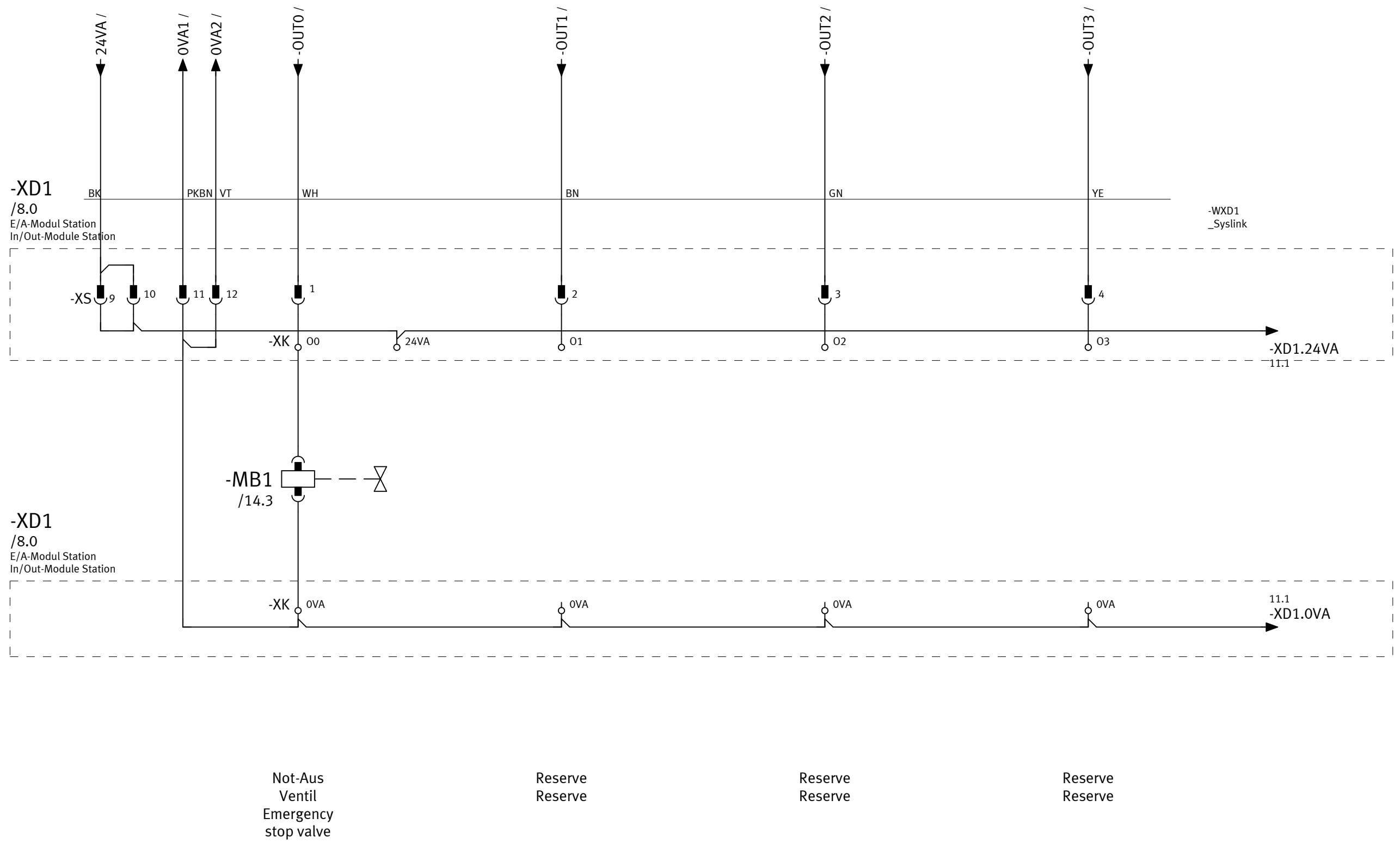

Datum	17.09.2018
Bearb.	Schuhmacher
Erst.	Schuhmacher
Ze.Nr.	V3436.E10

Festo Didactic SE
 Rechbergstraße 3
 D-73770 Denkendorf



Ausgänge
 outputs

S-Nr.	
PSP / DPJ	VN

= H	Muskelpresse	Seite 10
+ HL	Muskelpresse	von

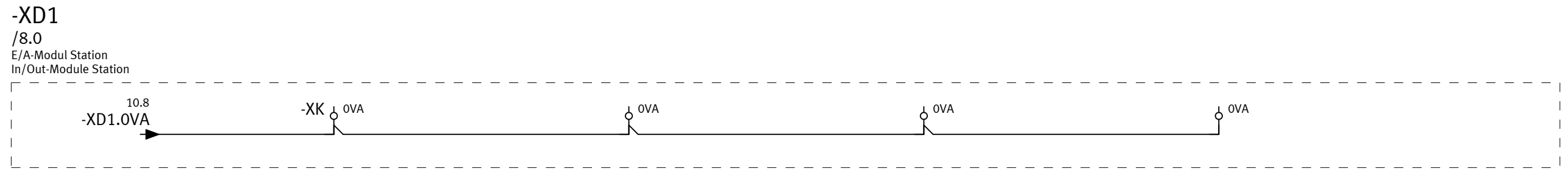
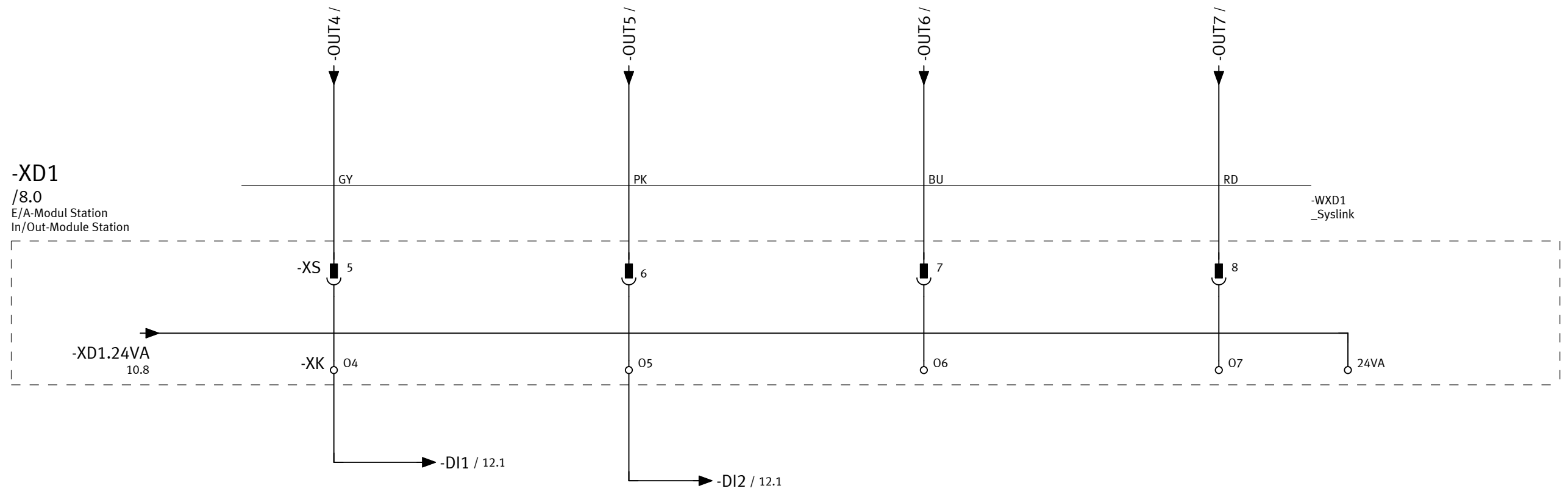

Druckregler Optionseingang DI1
Pressure regulator options entrance DI1

Druckregler Optionseingang DI2
Pressure regulator options entrance DI2

Reserve
Reserve

Reserve
Reserve

Datum	17.09.2018	Festo Didactic SE Rechbergstraße 3 D-73770 Denkendorf
Bearb.	Schuhmacher	
Erst.	Schuhmacher	
Ze.Nr.	V3436.E10	

FESTO

Ausgänge
outputs

S-Nr.			
PSP / DPJ	VN	= H	Muskelpresse
		+ HL	Muskelpresse
			Seite 11 von

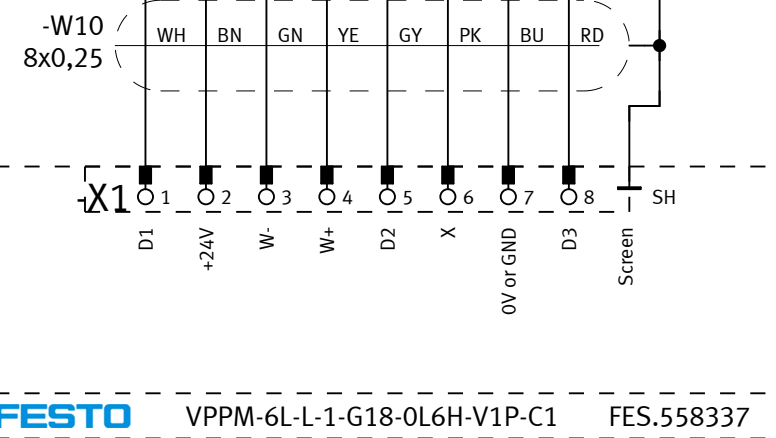
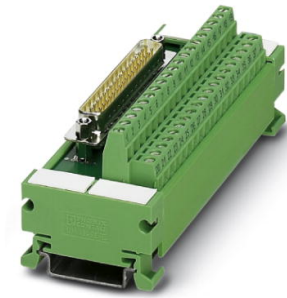

FESTO VPPM-6L-L-1-G18-0L6H-V1P-C1 FES.558337
Muskelpresse
muscle press

- 1 Digi. Input D1
- 2 +24V DC
- 3 Ana. Input -
- 4 Ana. Input +
- 5 Digi. Input D2
- 6 Ana. Output X
- 7 0V
- 8 Digi. Output D3

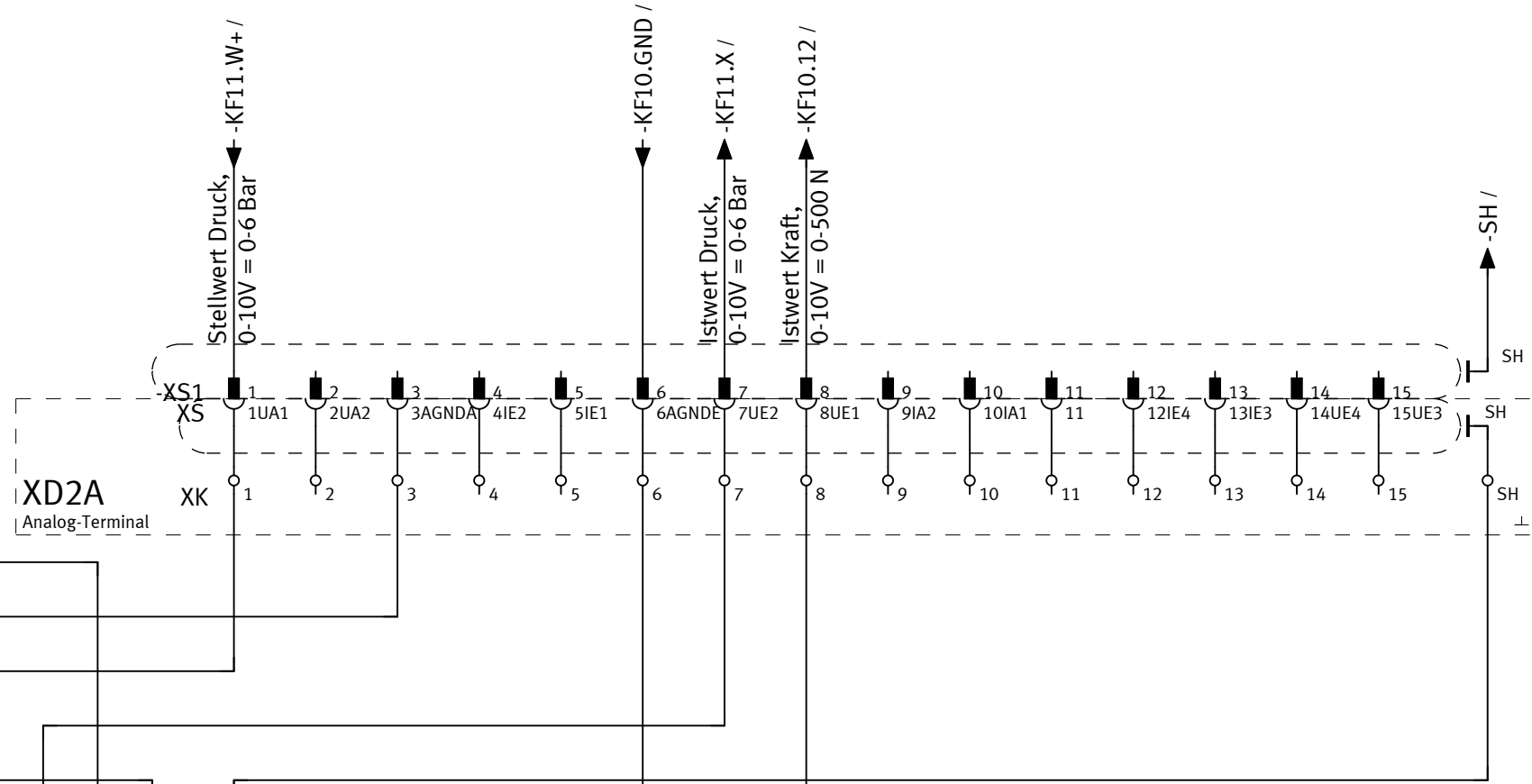

Bezeichnungen der SPS:
 UEx Spannungs-Eingang Kanal x
 UAx Spannungs-Ausgang Kanal x
 IEx Strom-Eingang Kanal x
 IAx Strom-Ausgang Kanal x
 AGNDE Analogmasse der Eingänge
 AGNDA Analogmasse der Ausgänge

Labling of PLC:
 UEx voltage input port x
 UAx voltage output port x
 IEx current input port x
 IAx current output port x
 AGNDE analog ground for inputs
 AGNDA analog ground for outputs

Verstärker
amplifier

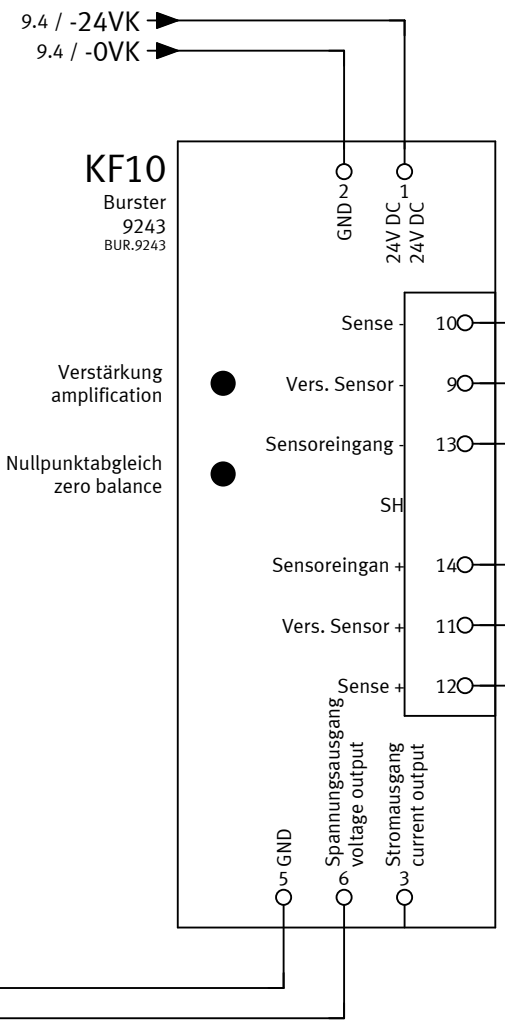

-BG10
Burster
Kraft Sensor



Datum	28.11.2019	Festo Didactic SE
Bearb.	Schuhmacher	Rechbergstraße 3
Erst.	Schuhmacher	D-73770 Denkendorf
Ze.Nr.	V3436.E10	



Analog
analog

S-Nr.			
PSP / DPJ	VN	= H	Muskelpresse
		+ HL	Muskelpresse
			Seite 12 von

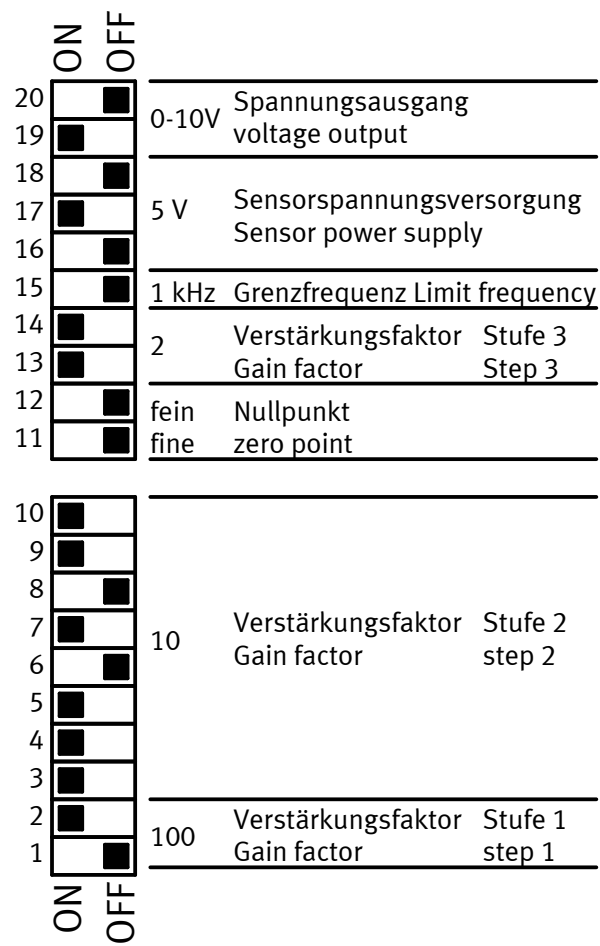

Datum	17.09.2018	Festo Didactic SE	
Bearb.	Schuhmacher	Rechbergstraße 3	
Erst.	Schuhmacher	D-73770 Denkendorf	
Ze.Nr.	V3436.E10	N:	F:



Messverstärker
measuring amplifier

S-Nr.			
PSP / DPJ	VN	= H	Muskelpresse
		+ HL	Muskelpresse
			Seite 13 von

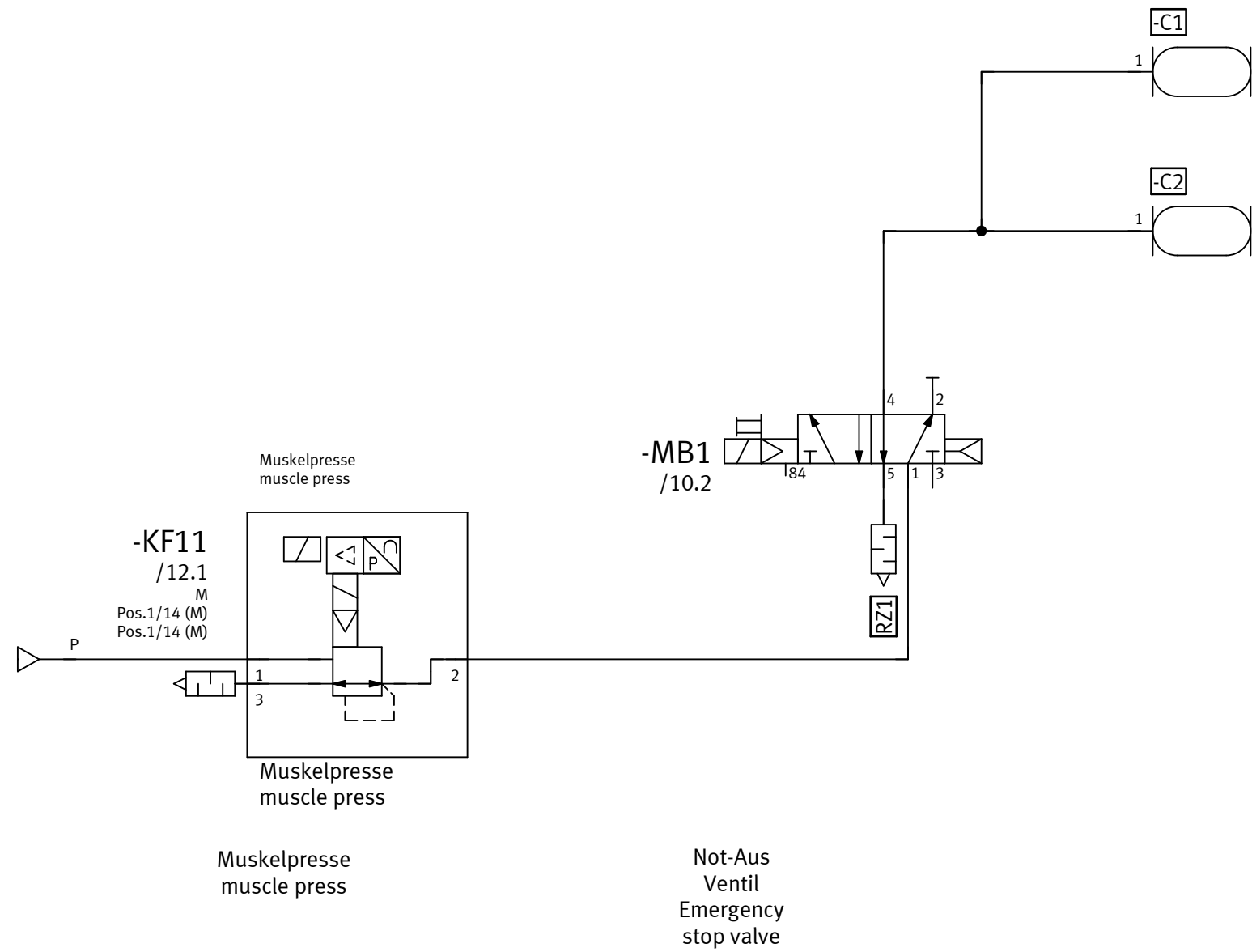

Datum	17.09.2018
Bearb.	Schuhmacher
Erst.	Schuhmacher
Ze.Nr.	V3436.E10

Festo Didactic SE
 Rechbergstraße 3
 D-73770 Denkendorf



Verpressen Pneumatik
 pressing pneumatics

S-Nr.	
PSP / DPJ	VN

= H	Muskelpresse	Seite 14
+ HL	Muskelpresse	von