

# 8155207

## Camera inspection-V2

# FESTO

CP Factory/CP Lab

Original operating  
instructions

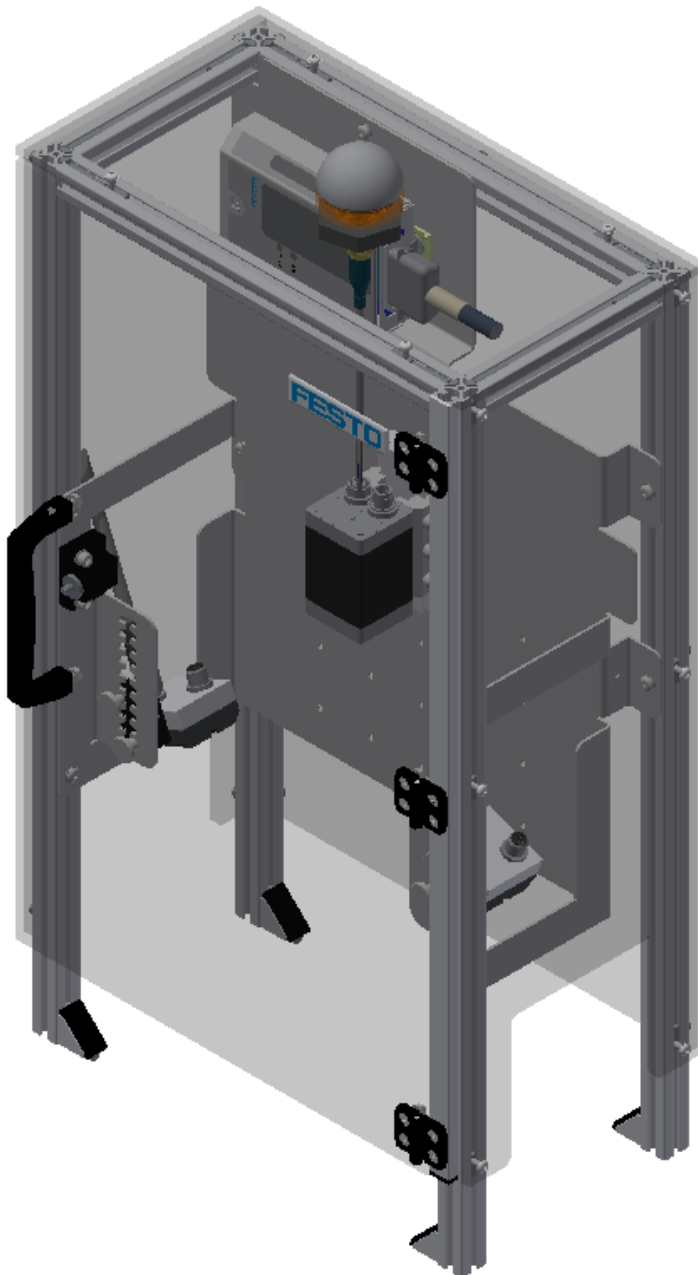

Order number: 8155207  
Revision Level: 05/2023  
Authors: Schober, Weiss  
Layout: Frank Ebel  
File Name: CP-AM-CAM-GB-8155207-A002.docx

© Festo Didactic SE, Rechbergstr. 3, 73770 Denkendorf, Germany, 2023



+49 711 3467-0

+49 711 34754-88500



[www.festo-didactic.com](http://www.festo-didactic.com)



[did@festo.com](mailto:did@festo.com)

Original operating instructions

© 2023 all rights reserved to Festo Didactic SE.



Where only pronouns such as he and him are used in these operating instructions, these pronouns are of course intended to refer to both male and female persons. The use of a single gender (e.g. he, him) should not be construed as gender discrimination; it is intended solely to make the manual easier to read and the formulations easier to understand.

	 <b>CAUTION</b>
	<p>These operating instructions must be available to the user at all times. The operating instructions must be read before commissioning. The safety instructions must be observed. Non-observance may result in severe personal injury or damage to property.</p>

### Main document

Associated documents attached:

Safety instructions concerning transport (print/electronic)

Component datasheets (print/electronic)

Circuit diagram (print/electronic)

# Contents

1	Safety instructions .....	5
1.1	Warning notice system .....	5
1.2	Pictograms .....	6
1.3	General prerequisites for installing the product.....	7
1.4	General prerequisites for operating the devices .....	7
2	Intended use .....	8
3	For your safety .....	9
3.1	Important information .....	9
3.2	Qualified persons .....	10
3.3	Obligations of the operating company .....	10
3.4	Obligations of the trainees .....	10
4	Basic safety instructions .....	11
4.1	General information .....	11
4.2	Mechanical components .....	11
4.3	Electrical components .....	12
4.4	Cyber security .....	14
4.5	Additional safety instructions .....	15
4.6	Guarantee and liability .....	16
4.7	Guarantee and liability for application examples .....	16
4.8	Transport.....	17
4.9	Name plates .....	18
4.10	CE Declaration of Conformity .....	19
4.11	General product safety .....	22
4.12	Protective devices .....	23
4.12.1	Emergency stop.....	23
4.12.2	Additional protective devices .....	23
4.13	Safety Sockets .....	24
5	Technical Data .....	26
6	Design and Function .....	28
6.1	Transport.....	28
6.2	Overview of the System.....	30
6.3	The application module camera inspection.....	31
6.4	Function .....	32
6.5	Sequence description.....	32
6.6	Electrical Connections .....	33
6.6.1	Overview .....	33
6.6.2	Profinet connections .....	33
6.6.3	I/O Module XD1.....	34
7	Commissioning .....	36
7.1	Workplace .....	36
7.2	Visual Inspection .....	37
7.3	Safety Regulations .....	37
7.4	Assembly.....	38
7.4.1	Assembly of an CP application module.....	38

7.4.2 Connecting the CP application module electrically to basic module CP Lab Conveyor .....	42
7.4.3 Pneumatic connection from application modules (option – not available at all application modules) .....	44
7.4.4 Assembly of an CP application module to a CP Factory basic module .....	45
7.4.5 Connecting the CP application module electrically to the CP Factory basic module .....	48
7.4.6 Stand alone operation .....	49
8 Operation .....	50
8.1 Setting the application module magazine at HMI .....	50
8.2 Transitions of the application module .....	53
8.3 Process of the application module .....	55
8.4 Flow chart .....	57
8.4.1 MES Parameter (CAM) .....	59
8.4.2 Default Parameter (CAM) .....	61
9 Message texts and interactive error messages at the HMI .....	62
9.1 Message texts .....	62
9.2 Interactive error messages .....	63
9.2.1 Default operation .....	63
9.2.2 MES Operation .....	64
9.2.3 General .....	65
9.2.1 Application module camera .....	65
10 Spare part list .....	66
10.1 Electric parts .....	66
11 Service and cleaning .....	67
12 Further information and updating .....	68
13 Disposal .....	69



# 1 Safety instructions



## 1.1 Warning notice system



These operating instructions contain notes that must be observed for your personal safety and in order to prevent property damage. The notes concerning your personal safety are indicated by a safety symbol.

Notes that only concern property damage are not indicated by a safety symbol.

The notes below are listed in order of hazard level.

	 <b>DANGER</b>
	... indicates an <b>imminently</b> hazardous situation that will result in fatal or severe personal injury if not avoided.

	 <b>WARNING</b>
	... indicates a <b>potentially</b> hazardous situation which may result in fatal or severe personal injury if not avoided.

	 <b>CAUTION</b>
	... indicates a <b>potentially</b> hazardous situation that may result in moderate or slight personal injury or severe property damage if not avoided.

	<b>NOTE</b>
	... indicates a <b>potentially</b> hazardous situation that may result in property damage or loss of function if not avoided.

In cases where more than one hazard level applies, the safety note with the highest hazard level will be shown. A safety note may concern both personal injury and property damage.

Hazards that will only result in property damage are indicated with the word "Note".

## 1.2 Pictograms

This document and the hardware described in it include warnings concerning possible hazards which may arise if the system is used incorrectly.

The following pictograms are used:



Hazard warning



Warning - dangerous electric voltage



Read and observe the operating and safety instructions prior to commissioning.



Warning – lifting heavy loads



Information and/or references to other documentation

### 1.3 General prerequisites for installing the product

- Festo Didactic products must only be used for the applications specified in their respective operating instructions. Products or components supplied by other manufacturers must only be used if recommended or approved by Festo.
- The products must be transported, stored, installed, assembled, commissioned, operated and maintained properly in order to ensure their safe operation.
- The approved ambient conditions must be observed. The specifications in the relevant operating instructions must be observed.
- The safety equipment must be tested every working day.
- Connecting cables must be checked for damage before each use. In case of damage, they must be replaced.

Connecting cables must correspond to the minimum specifications.

### 1.4 General prerequisites for operating the devices

General requirements for safe operation of the system:

- In industrial facilities, the national accident prevention regulations must be observed.
- The laboratory or classroom must be overseen by a supervisor.
  - A supervisor is a qualified electrician or a person who has been trained in electrical engineering, knows the respective safety requirements and safety regulations, and whose training has been documented accordingly.

The laboratory or the classroom must be equipped with the following devices:

- An emergency-off device must be provided.
  - At least one emergency-off device must be located inside the laboratory or the classroom, and at least one outside it.
- The laboratory or classroom must be secured so that the operating voltage and compressed air supply cannot be activated by any unauthorized persons, for example by means of:
  - e.g. a keyswitch
  - e.g. lockable shut off valves
- The laboratory or classroom must be protected by residual current devices (RCDs).
  - RCDs with a differential current of  $\leq 30$  mA, Type B. When operating machinery with unavoidable leakage current, suitable measures must be implemented and documented in the corresponding workplace risk assessment.
- The laboratory or classroom must be protected by overcurrent protection devices.
  - Fuses or circuit breakers
- Devices must not be used if they are damaged or defective.
  - Damaged devices must be barred from further use and removed from the laboratory or classroom.
  - Damaged connecting cables, pneumatic tubing and hydraulic hoses represent a safety risk and must be removed from the laboratory or classroom.
- Safety devices must be checked every working day to ensure that they are fully functional.
- Connecting cables and accessories must be checked for damage before each use.

## 2 Intended use

Festo Didactic systems and components must only be used:

- For their intended use in teaching and training applications
- When their safety functions are in perfect condition

The components and systems are designed in accordance with the latest technology and recognized safety rules. However, life and limb of the user and third parties may be endangered and the components may be impaired if they are used incorrectly.

The Festo Didactic learning system has been developed and produced exclusively for education and training in the field of automation technology. The training company and/or trainers must ensure that all trainees observe the safety precautions described in these operating instructions.

Training with complex machinery is a highly hazardous activity. The operating company must draw up and document a workplace risk assessment. The trainees must be briefed on all the relevant safety aspects before work commences.

**Festo Didactic hereby excludes any and all liability for damages suffered by apprentices, the training company and/or any third parties, which occur during use of the device in situations which serve any purpose other than training and/or vocational education, unless such damages have been caused by Festo Didactic due to malicious intent or gross negligence.**

All extensions and accessories must be approved by Festo Didactic, and are only permitted for use for their intended purpose.

The machine fulfils the requirements of the European directives that applied when it was commissioned. Any modification to the machine shall render the manufacturer's CE Declaration of Conformity null and void. The CE Declaration of Conformity must be renewed following each major modification.



## 3 For your safety

### 3.1 Important information

Knowledge of the basic safety instructions and safety regulations is a fundamental prerequisite for safe handling and trouble-free operation of Festo Didactic components and systems.

These operating instructions include the most important instructions for safe use of the components and systems. In particular, the safety instructions must be adhered to by all persons who work with these components and systems. Furthermore, all pertinent accident prevention rules and regulations that are applicable at the respective place of use must be adhered to.

	 <b>WARNING</b>
	<ul style="list-style-type: none"><li>• <b>Malfunctions which could impair safety must be eliminated immediately!</b></li></ul>

	 <b>CAUTION</b>
	<ul style="list-style-type: none"><li>• <b>Improper repairs or modifications may result in unforeseeable operating statuses. Do not carry out any repair or alternation work on components or systems that is not described in these operating instructions.</b></li></ul>

### **3.2 Qualified persons**

- The product described in these operating instructions is only permitted for operation by persons who are qualified for the task in question in accordance with the operating instructions, especially the safety instructions.
- Qualified persons are defined as persons whose training and experience enables them to recognize risks and avoid potential dangers when working with this product.

### **3.3 Obligations of the operating company**

It is the responsibility of the operating company to ensure that the station is operated safely.

The operating company undertakes to allow only those persons to work with the components and systems who:

- Are familiar with the basic regulations regarding occupational safety, with the safety instructions, and with the accident prevention regulations, and who have been instructed in the use of the components and systems
- Have read and understood the safety chapter and warnings in these operating instructions
- Are qualified to operate the components and systems in question
- Are governed by and trained in suitable organizational measures to ensure safe training

Personnel should be tested at regular intervals to ensure that they are safety-conscious in their work habits.



### **3.4 Obligations of the trainees**

All persons who have been entrusted to work with the components and systems undertake to complete the following steps before beginning work:



- Read the chapter concerning safety and the warnings in these operating instructions
- Familiarize themselves with the basic regulations regarding occupational safety and accident prevention



## 4 Basic safety instructions

### 4.1 General information



	 <b>CAUTION</b>
	<ul style="list-style-type: none"> <li>• <b>Trainees must be supervised by an instructor at all times when working with the components and systems.</b></li> <li>• <b>Observe the specifications included in the technical data for the individual components, and in particular all the safety instructions!</b></li> <li>• <b>Wear your personal protective equipment (safety goggles, safety shoes).</b></li> <li>• <b>Never leave objects lying on the top of protective enclosures. Vibrations could cause such objects to fall off.</b></li> </ul>



### 4.2 Mechanical components

	 <b>WARNING</b>
	<ul style="list-style-type: none"> <li>• <b>Switch off the power supply!</b> <ul style="list-style-type: none"> <li>– Switch off both the operating power and the control power before commencing work on the circuit.</li> <li>– Never reach into the setup unless it is at a complete standstill.</li> <li>– Be aware of potential overtravel times for the actuators.</li> </ul> </li> <li>• <b>Risk of injury during troubleshooting!</b> <ul style="list-style-type: none"> <li>– Use a tool such as a screwdriver for actuating sensors.</li> </ul> </li> </ul>

	 <b>CAUTION</b>
	<ul style="list-style-type: none"> <li>• <b>Risk of burns due to hot surfaces</b> <ul style="list-style-type: none"> <li>– Devices can reach high temperatures during operation, as a result of which they can cause burns if touched.</li> </ul> </li> <li>• <b>Measures to take when maintenance is required.</b> <ul style="list-style-type: none"> <li>– Allow the device to cool off before commencing work.</li> <li>– Use suitable personal protective clothing, e.g. safety safety gloves.</li> </ul> </li> </ul>

### 4.3 Electrical components

	 <b>WARNING</b>
	<ul style="list-style-type: none"> <li>• <b>Disconnect from all sources of electrical power!</b> <ul style="list-style-type: none"> <li>– Switch off the power supply before working on the circuit.</li> <li>– Please note that electrical energy may be stored in individual components. Further information on this issue is available in the datasheets and operating instructions included with the components.</li> <li>– <b>Warning!</b> Capacitors inside the device may still be charged even after being disconnected from all sources of voltage.</li> </ul> </li> <li>• <b>Danger due to malfunction</b> <ul style="list-style-type: none"> <li>– Never place or leave liquids (e.g. drinks) on the station in open containers.</li> <li>– The machine must not be switched on if there is condensation (moisture) on its surface.</li> <li>– Never lay pipes/hoses designed to carry liquid media near the machine.</li> </ul> </li> <li>• <b>Electric shock due to connection to unsuitable power supply!</b> <ul style="list-style-type: none"> <li>– When devices are connected to an unsuitable power supply, exposed components can cause dangerous electrical voltage that can lead to severe or fatal injury.</li> <li>– Always use power supplies that provide SELV (safety extra-low voltage) or PELV (protective extra-low voltage) output voltages for all the connections and terminals on the electronics modules.</li> </ul> </li> <li>• <b>Electric shock when there is no protective grounding in place</b> <ul style="list-style-type: none"> <li>– If there is no protective grounding terminal in place for a Protection Class I device, or if the protective grounding terminal has not been installed correctly, exposed, conductive parts may carry high voltages, thus causing severe or fatal injury if touched.</li> <li>– Ground the device in accordance with the applicable regulations.</li> </ul> </li> </ul>

	 <b>WARNING</b>
	<ul style="list-style-type: none"> <li>• <b>Risk of fire due to use of unsuitable power supply</b> <ul style="list-style-type: none"> <li>– If a device is connected to an unsuitable power supply, this can cause components to overheat, leading to a breakout of fire.</li> <li>– Always use limited power supplies (LPSs) for all the connections and terminals on the electronics modules.</li> </ul> </li> </ul>

**CAUTION**

- **Always ensure that your connecting cables are designed for use with the electrical connections in question.**
- **When laying connecting cables, make sure they are not kinked, sheared or pinched. Cables laid on the floor must be covered with a cable bridge to protect them.**
- **Do not lay cables over hot surfaces.**
  - Hot surfaces are identified with a corresponding warning symbol.
- **Make sure that connecting cables are not subjected to continuous tensile loads.**
- **Devices with a grounding terminal must always be grounded.**
  - If a ground connection (green-yellow laboratory socket) is available, it must always be connected to the protective grounding. The protective grounding must always be connected first (before voltage) and disconnected last (after disconnecting the voltage).
  - Some devices have high leakage current. These devices must be fitted with a grounding conductor for additional grounding.
- **When replacing fuses, always use specified fuses with the correct current rating and tripping characteristics.**
- **The device is not equipped with a built-in fuse unless otherwise specified in the technical data.**
- **Safe operation of the device is not possible in the event of any of the following circumstances:**
  - Visible damage
  - Malfunction
  - Inappropriate storage
  - Incorrect transportSwitch off the power supply immediately.
- **Protect the device to prevent it from being restarted accidentally.**



#### 4.4 Cyber security

Festo Didactic offers products with security functions that aid the safe operation of plants, systems, machines and networks. In order to protect plants, systems, machines and networks from cyber threats, a comprehensive security concept must be implemented and continuously updated. Festo's products and services only constitute one part of such a concept.

The customer is responsible for preventing unauthorized access to their plants, systems, machines and networks. Systems, machines and components should only be connected to a company's network or the Internet if and as necessary, and only when the suitable security measures (e.g., firewalls and network segmentation, defense-in-depth) are in place. Failure to ensure adequate security measures when connecting the product to the network can result in vulnerabilities which allow unauthorized, remote access to the network – even beyond the product's boundaries. This access could be abused to incur a loss of data or manipulate or sabotage systems. Typical forms of attack include but are not limited to: Denial-of-Service (rendering the system temporarily non-functional), remote execution of malicious code, privilege escalation (executing malicious code with higher system privileges than expected), ransomware (encryption of data and demanding payment for decryption). In the context of industrial systems and machines this can also lead to unsafe states, posing a danger to people and equipment.

Furthermore, Festo's guidelines on suitable security measures should be observed. Festo products and solutions are constantly being developed further in order to make them more secure. Festo strongly recommends that customers install product updates as soon as they become available and always use the latest versions of its products. Any use of product versions that are no longer supported or any failure to install the latest updates may render the customer vulnerable to cyber-attacks.

Support Festo in ensuring your continued safety. Please report any security findings to the Festo Product Security Incidence Response Team (PSIRT) in German or English language, by email to [psirt@festo.com](mailto:psirt@festo.com) or online contact form at <https://www.festo.com/psirt>.

 <b>WARNING</b>	
	<ul style="list-style-type: none"> <li>• <b>Unsecure operating conditions due to software tampering</b> <ul style="list-style-type: none"> <li>– Forms of software tampering (e.g. viruses, Trojans, malware and worms) can lead to unsecure operating conditions in your system, which may in turn lead to severe or fatal injury or property damage.</li> <li>– Keep your software up to date.</li> <li>– Integrate the automation and actuator components into an overarching and comprehensive industrial security concept for the installation or machine in question that is in line with the latest technological developments.</li> <li>– Make sure that all the products you have installed are incorporated into your overarching industrial security concept.</li> <li>– Use suitable measures, such as a virus scanner, to protect files save on exchangeable storage media from malware.</li> </ul> </li> </ul>

#### 4.5 Additional safety instructions

General requirements for safe operation of the devices:

- Do not lay cables over hot surfaces.
  - Hot surfaces are identified with a corresponding warning symbol.
- Maximum permissible current loads for connector cables and devices must not be exceeded.
  - Always compare the current ratings of the device, the cable and the fuse to ensure that they match.
  - If they do not match, use a separate upstream fuse in order to provide appropriate overcurrent protection.
- Devices with a grounding terminal must always be grounded.
  - If a ground terminal (green-yellow laboratory socket) is available, it must always be connected to protective ground. The protective grounding must always be connected first (before voltage) and disconnected last (after disconnecting the voltage).
- The device is not equipped with a built-in circuit unless otherwise specified in the technical data.

	 <b>WARNING</b>
	<ul style="list-style-type: none"><li>• <b>This product is designed for use in industrial environments, and may cause malfunctions if used in domestic or small commercial environments.</b></li></ul>

#### **4.6 Guarantee and liability**

Our General Terms and Conditions of Sale and Delivery shall apply at all times. These shall be made available to the operating company no later than upon conclusion of the sales contract. Guarantee and liability claims resulting from personal injury and/or property damage are excluded if they can be traced back to one or more of the following causes:



- Use of the equipment for purposes other than its intended use
- Improper installation, commissioning, operation or maintenance of the system
- Operation of the system with defective safety equipment, or with improperly attached or non-functional safety equipment and protective guards
- Non-compliance with directions included in the operating instructions with regard to transport, storage, installation, commissioning, operation, maintenance and setup of the system
- Unauthorized modifications to the system
- Improperly executed repairs
- Disasters resulting from the influence of foreign bodies and acts of God
- Dust generated during construction work must be kept away from the system (use coverings).  
See the Environmental Requirements section (contamination level) for more details.

#### **4.7 Guarantee and liability for application examples**

The application examples are not legally binding, and we cannot guarantee their completeness in terms of their configuration, their equipment or any events that may occur. The application examples are not representations of any specific customer solution; they are merely intended to illustrate typical tasks for which the product in question could be used. You bear the responsibility for ensuring that the products described here are operated properly. These application examples do not in any way relieve you of your responsibility to ensure that the system is handled safely when it is being used, installed, operated or maintained.



## 4.8 Transport

	 <b>WARNING</b>
	<ul style="list-style-type: none"><li>• <b>Danger due to tipping over</b><ul style="list-style-type: none"><li>– Suitable packaging and transport equipment must be used when transporting the station. The station can be lifted from underneath using a forklift truck. Please note that eccentric centers of gravity can cause the station to tip over.</li><li>– Stations with attachments at height will have a high center of gravity.</li><li>– Take care to avoid tipping over during transportation.</li></ul></li></ul>

	<i><b>NOTE</b></i>
	<ul style="list-style-type: none"><li>• <b>Station contains delicate components!</b><ul style="list-style-type: none"><li>– Take care not to shake during transportation</li></ul></li><li>• <b>The station is only permitted for installation on solid, non-vibrating surfaces.</b><ul style="list-style-type: none"><li>– Make sure that the ground underneath the station has sufficient load-bearing capacity.</li></ul></li></ul>

4.9 Name plates



Name plate example

Position	Description
1	Maximum pressure pneumatic (if available)
2	current consumption
3	Operating voltage
4	Serial number
5	Type number (Ordernumber) aaaaaa-aa (canadian nomenclature) bbbbbbbb (german nomenclature)
6	CE idenification
7	WEEE identification
8	Country of origin
9	Production year
10	Weight
11	Data Matrix Code (Type-and serial number)

## 4.10 CE Declaration of Conformity

# FESTO

(DE) Die alleinige Verantwortung für die Ausstellung dieser Konformitätserklärung trägt der Hersteller. Der beschriebene Gegenstand der Erklärung erfüllt die einschlägigen Harmonisierungsrechtsvorschriften der Union.

(EN) This declaration of conformity is issued under the sole responsibility of the manufacturer. The object of the declaration described is in conformity with the relevant Union harmonisation legislation.

(BG) Настоящата декларация за съответствие е издадена на отговорността на производителя. Предметът на описаната декларация отговаря на съответното законодателство на Съюза за хармонизация.

(CS) Toto prohlášení o shodě se vydává na výhradní odpovědnost výrobce. Popsaný předmět prohlášení je ve shodě s příslušnými harmonizačními právními předpisy Unie.

(DA) Denne overensstemmelseserklæring udstedes på fabrikantens ansvar. Genstanden for erklæringen, som beskrevet, er i overensstemmelse med den relevante EU-harmoniseringslovgivning.

(EL) Η παρούσα δήλωση συμμόρφωσης εκδίδεται με αποκλειστική ευθύνη του κατασκευαστή. Ο περιγραφόμενος στόχος της δήλωσης είναι σύμφωνος με τη σχετική ενωσιακή νομοθεσία εναρμόνισης.

(ES) La presente declaración de conformidad se expide bajo la exclusiva responsabilidad del fabricante. El objeto de la declaración descrita es conforme con la legislación de armonización pertinente de la Unión.

(ET) Käesolev vastavusdeklaratsioon on välja antud tootja ainuvastutusel. Kirjelatud deklareeritav toode on kooskõlas asjaomaste liidu ühtlustamisaktidega.

(FI) Tämä vaatimustenmukaisuusvakuutus on annettu valmistajan yksinomaisella vastuulla. Kuvattu vakuutuksen kohde on asiaa koskevan unionin yhdenmukais-tamislaainsäädännön vaatimusten mukainen.

(FR) La présente déclaration de conformité est établie sous la seule responsabilité du fabricant. L'objet décrit de la déclaration est conforme à la législation d'harmonisation de l'Union applicable.

(HU) Ezt a megfélelőségi nyilatkozatot a gyártó kizárólagos felelőssége mellett adják ki. Az ismertetett nyilatkozat tárgya megfelel a vonatkozó uniós harmonizációs jogszabályoknak.

(IT) La presente dichiarazione di conformità è rilasciata sotto la responsabilità esclusiva del fabbricante. L'oggetto della dichiarazione descritto è conforme alla pertinente normativa di armonizzazione dell'Unione.

(LT) Ši atitikties deklaracija išduota tik gamintojo atsakomybe. Aprašytas deklaracijos objektas atitinka susijusius derinamuosius Sąjungos teisės aktus.

(LV) Šī atbilstības deklarācija ir izdota vienīgi uz ražotāja atbildību. Aprakstītais deklarācijas objekts atbilst attiecīgajam Savienības saskaņošanas tiesību aktam.

(NL) Deze conformiteitsverklaring wordt verstrekt onder volledige verantwoordelijkheid van de fabrikant. Het beschreven voorwerp is in overeenstemming de desbetreffende harmonisatiewetgeving van de Unie.

(PL) Niniejsza deklaracja zgodności wydana zostaje na wyłączną odpowiedzialność producenta. Wymieniony przedmiot niniejszej deklaracji jest zgodny z odpowiednimi wymaganiami unijnego prawodawstwa harmonizacyjnego.

(PT) A presente declaração de conformidade é emitida sob a exclusiva responsabilidade do fabricante. O objeto da declaração descrito está em conformidade com a legislação aplicável de harmonização da União.

(RO) Prezenta declarație de conformitate este emisă pe răspunderea exclusivă a producătorului. Obiectul descris al declarației este în conformitate cu legislația relevantă de armonizare a Uniunii.

(SK) Toto vyhlásenie o zhode sa vydáva na vlastnú zodpovednosť výrobcu. Uvedený predmet vyhlásenia je v zhode s príslušnými harmonizačnými právnymi predpismi Únie.

(SL) Za izdajo te izjave o skladnosti je odgovoren izključno proizvajalec. Opisani predmet izjave je v skladu z ustreznimi zakonodajo Unije o harmonizaciji.

(SV) Denna försäkran om överensstämmelse utfärdas på tillverkarens eget ansvar. Föremålet för försäkran överensstämmer med den relevanta harmoniserade unionslagstiftningen.

(TR) Bu Uygunluk Belgesi tamamen üreticinin sorumluluğunda altındadır. Belgede açıklanan obje, Birliğin ilgili uyum mevzuatına uygundur.

EG-Konformitätserklärung  
EU Declaration of Conformity  
Декларация за съответствие на ЕС  
Prohlášení o shodě ES  
EF-overensstemmelseserklæring  
Αήλωξη ζυμμόρφωσης ΕΚ  
Declaración de conformidad CE  
EÜ vastavusdeklaratsioon  
EY-vaatimustenmukaisuusvakuutus  
Déclaration CE de conformité  
EK megfélelőségi nyilatkozat  
Dichiarazione di conformità EU  
EB atitikties deklaracija  
EK atbilstības deklarācija  
EG-verklaring van  
overeenstemming  
Deklaracja zgodności WE  
Declaração de conformidade CE  
Declarație de conformitate CE  
Vyhlásenie o zhode ES  
Izjava ES o skladnosti  
EG-försäkran om Överensstämmelse

The installation instructions according to the manual have to be followed. The person authorized to compile the technical documents is Philippe Drolet, Product conformity, Festo Didactic Ltée/Ltd. Canada.

Festo Didactic Ltée/Ltd. · 675 rue du Carbone · Québec, QC G2N 2K7 · CANADA · www.festo-didactic.com

8101137 – DoC0039

# FESTO

2022-03-02

<b>8032510</b>	<b>CP-AM-DRILL</b>
<b>8032507</b>	<b>CP-AM-PRESS</b>
<b>8032508</b>	<b>CP-AM-MAG</b>
<b>8032509</b>	<b>CP-AM-TURNOVER</b>
<b>8032511</b>	<b>CP-AM-CAM</b>
<b>8038567</b>	<b>CP-AM-MPRESS</b>
<b>8043598</b>	<b>CP-AM-IDRILL-C21</b>
<b>8050101*</b>	<b>CP-L-LINEAR-C11-M0</b>
<b>8050102*</b>	<b>CP-L-LINEAR-C13-M0</b>
<b>8058667*</b>	<b>CP-L-BRANCH-C21</b>
<b>8061184</b>	<b>CP-AM-OUT</b>
<b>8068413</b>	<b>CP-AM-iPICK-C21</b>
<b>8088783</b>	<b>CP-AM-OVEN-230V</b>
<b>8091107</b>	<b>CP Lab HMI Panel</b>
<b>8092833*</b>	<b>SC CP LAB STD CFG 4</b>
<b>8092834*</b>	<b>SC CP LAB STD CFG 6</b>
<b>8092835*</b>	<b>SC CP LAB STD CFG 8</b>
<b>8092836*</b>	<b>SC CP LAB STD CFG 10</b>
<b>8108237*</b>	<b>CP-L-LINEAR-C11-M6</b>
<b>8129428</b>	<b>CP-Lab/MPS HMI Panel</b>
<b>8132970*</b>	<b>CP-L-LINEAR-C11-M0-V2</b>
<b>8146023*</b>	<b>CP-L-LINEAR-C13-M0-V2</b>
<b>8146024*</b>	<b>CP-L-LINEAR-C11-M6-V2</b>
<b>8152450</b>	<b>CP-AM-LABEL-V2</b>
<b>8154245</b>	<b>CP-AM-MEASURE-V2</b>
<b>8155207</b>	<b>CP-AM-CAM-V2</b>
<b>8167762*</b>	<b>CP-L-LINEAR-C11-M0 V2</b>
<b>8167762*</b>	<b>CP-L-LINEAR-C11-M0 V2</b>
<b>8167764*</b>	<b>CP-L-LINEAR-C11-M6 V2</b>
<b>8172797*</b>	<b>CP-L-LINEAR-NO-PLC-M0</b>
<b>2006/42/EC</b>	<b>EN 60204-1:2018</b>
<b>2014/30/EU</b>	<b>EN 61326-1:2013-01</b>
<b>2011/65/EU</b>	<b>EN 63000:2016-10</b>
<b>2014/53/EU*</b>	<b>See Appendix A for details</b>

# FESTO

## Festo Didactic Ltée/Ltd

675 rue du Carbone  
 Québec, QC G2N 2K7  
 Canada  
 www.festo-didactic.com

  
 Francis Larrivée, ing.  
 Engineering

  
 Philippe Drolet, ing.  
 Product Compliance

### Appendix A:

Extracted from: Siemens EU-Declaration of Conformity No. A5E50679864A; REV.: 001 /  
[CE-DoC\\_A5E50679864A\\_RF200R\\_RF300R\\_RED\\_RoHS\\_2020-12-11.pdf \(siemens.com\)](#)

## SIEMENS

### Anhang RED & RoHS / Annex RED & RoHS zur EU-Konformitätserklärung / to EU-Declaration of Conformity Nr./No. A5E50679864A; REV.: 001

Produktgruppenbezeichnung/-modell SIMATIC RF200R / RF300R HF RFID READERS  
 Product group identification/-model (13.56 MHz)

Die Übereinstimmung der bezeichneten Produkte (unter Verwendung des Zubehörs) des oben genannten Gegenstandes mit den Vorschriften der angewandten Richtlinie(n) wird nachgewiesen durch die vollständige Einhaltung folgender Normen / Vorschriften (variantenabhängig, siehe Anhang Produkte - Tabelle 1. Angewandte Normen werden durch ein „x“ gekennzeichnet, wohingegen nicht angewandte Normen durch ein „-“ gekennzeichnet werden.):

*The conformity of the designated products (using the accessory) of the object described above with the provisions of the applied Directive(s) is proved by full compliance with the following standards / regulations (depending on versions, see annex Products - Table 1. Applicable Standards are marked by a "x" whereas not applicable Standards are marked by a "-");*

#### Art. 3 (1) a) Schutz der Gesundheit und Sicherheit - Normen / Health and Safety - standards:

Referenznummer Reference number	Ausgabedatum Date of issue	Referenznummer Reference number	Ausgabedatum Date of issue
EN 62368-1 + A11	2014/2017	EN 50364	2018

#### Art. 3 (1) b) EMV Normen / EMC standards:

Referenznummer Reference number	Ausgabedatum Date of issue	Referenznummer Reference number	Ausgabedatum Date of issue
ETSI EN 301 489-1	V2.2.3	EN IEC 61000-6-1	2019
ETSI EN 301 489-3	V2.1.1	EN IEC 61000-6-2	2019
EN 55011 + A1 + A11	2016/2017/2020	EN 61000-6-3 + A1	2007/2011
EN 55032 + A11 Class A/B	2015/2020	EN IEC 61000-6-4	2019
EN 55035 + A11	2017/2020	EN IEC 61000-6-8	2020



#### Art. 3 (2) Effiziente Nutzung des Funkspektrums Harmonisierte Normen / Efficient usage of spectrum Harmonized standards:

Referenznummer Reference number	Ausgabedatum Date of issue	Referenznummer Reference number	Ausgabedatum Date of issue
ETSI EN 300 330	V2.1.1		

#### Art. 3 (3) a)-l) Delegierte Rechtsakte für Funkanlagen / Delegated acts for Radio equipment



Referenznummer Reference number	Ausgabedatum Date of issue	Referenznummer Reference number	Ausgabedatum Date of issue

#### 4.11 General product safety

 <b>WARNING</b>	
	<ul style="list-style-type: none"><li>• <b>General product safety, CE conformity</b><ul style="list-style-type: none"><li>– The product fulfills the requirements of all applicable EU directives. We confirm this with the CE mark.</li><li>– As a consequence of Changes (hardware / software) Additions or improper use Product safety can no longer be guaranteed by the operator. In this case, the manufacturer's CE declaration of conformity expires. The operator must re-evaluate the safety and determine the CE conformity.</li></ul></li></ul>

#### 4.12 Protective devices

In order to reduce risks, this machine contains guards to prevent access to dangerous areas. These guards must not be removed or tampered with.

	 <b>WARNING</b>
	<ul style="list-style-type: none"><li>• <b>Damage to the safety window</b><ul style="list-style-type: none"><li>– Windows must not be cleaned using aggressive or alcoholic cleaning agents. Risk of brittleness and breakage!</li><li>– This protective device must be replaced if it shows any signs of damage. Please contact our Service department to arrange this.</li></ul></li></ul>

##### 4.12.1 Emergency stop











If a station has an emergency stop button, the emergency stop signal switches off all actuators. An acknowledgment by the operator is required for a restart, there is no automatic restart.

##### 4.12.2 Additional protective devices

The individual components, such as the power supplies and the controllers, possess built-in safety functions such as short-circuit protection, overcurrent protection, overvoltage protection and thermal monitoring. If necessary, consult the instruction manual for the device in question for more information.

### 4.13 Safety Sockets

Unless otherwise indicated in the technical data, the following color coding applies for supply and signal connections on components of the Festo Didactic Automation and Technology Learning System.

Color	Function	Color	Function
	Voltage greater than SELV e.g. supply voltage of 90 to 400 V AC per conductor external conductor L1 (grey-brown)		24 V DC (red)
	Voltage greater than SELV e.g. supply voltage of 90 to 400 V AC per conductor external conductor L2 (grey-black)		0 V DC (blue)
	Voltage greater than SELV e.g. supply voltage of 90 to 400 V AC per conductor external conductor L3 (grey-dark grey)		SELV Signal input/signal output (black)
	Voltage greater than SELV e.g. supply voltage of 90 to 400 V AC per conductor external conductor (grey)		
	Neutral conductor (grey-blue)		
	PE conductor, configuration as 4 mm safety socket (green-yellow)		
	Protective grounding terminal as PE+ contact, delivery status (green-yellow)		





Depending on the type of component, some of the safety sockets listed may not be present. The circuit design may contain additional safety sockets due to the use of different components.

The specified protection class and safe use can only be assured if laboratory safety cables supplied by Festo Didactic are used.



The protective grounding terminal is designed as PE+ contact. This connection provides a low-impedance, safe protective grounding conductor connection. The mechanically incompatible connection prevents a connection error with a 4 mm laboratory safety cable.

The operator bears the responsibility for any removal of this adapter. The adapter can be unscrewed with a 1.5 mm socket head screw. The detent is located in the drilled hole of the adapter. Unscrew the screw in clockwise direction.

	 <b>WARNING</b>
	<b>Danger of electric shock!</b> Damaged safety laboratory cables must be blocked immediately and removed from the laboratory area!

## 5 Technical Data

Parameter	Value
<b>Electrics</b>	
Power supply	24 V DC, 4.5 A safe low voltage (PELV)
Digital inputs	6
Digital outputs	8
<b>Ambient conditions</b>	
Operating environment	Use inside building only
Ambient temperature	5°C ... 40°C
Rel. air humidity	80% up to 31°C
Pollution degree	2, Dry, non-conductive contamination
Operating height	Up to 2000 m above NN (sea level)
Noise emission level	$L_{pA} < 70$ dB
<b>Certification</b>	
CE marking in accordance with:	Machinery Directive EMC Directive RoHS Directive
EMC environment	Industrial environment, Class A (in acc. with EN 55011)
<b>Measurements</b>	
Length	357 mm
Width	238 mm
Height	644 mm
Weight	Ca. 8,3 kg
<b>Subject to change</b>	

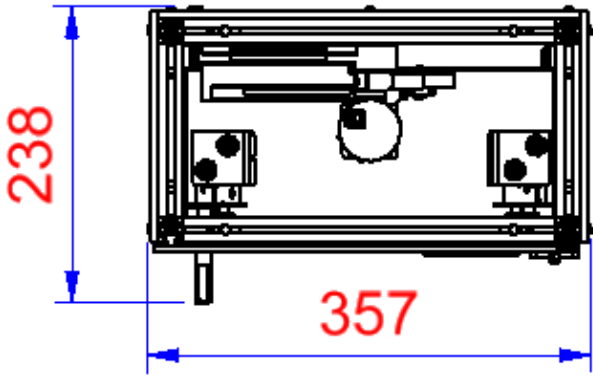
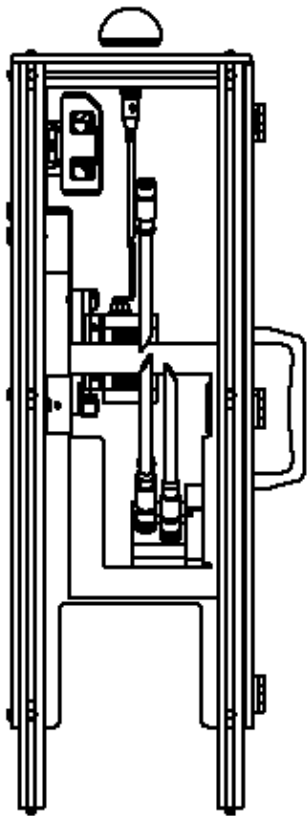
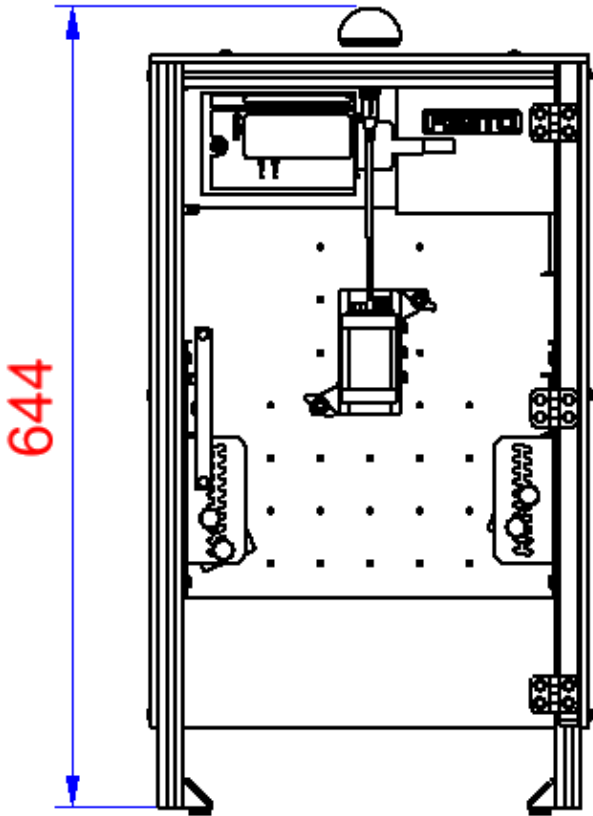







Illustration similar

## 6 Design and Function

### 6.1 Transport

	 <b>WARNING</b>
	<ul style="list-style-type: none"> <li>• <b>Damage to transport equipment when moving heavy machines/machine sections</b> <ul style="list-style-type: none"> <li>– When the stations are shipped out, extra care must be taken to ensure that heavy machines/machine sections are always transported using a suitable forklift truck. A single station can weigh up to 50 kg.</li> <li>– Always use suitable transport equipment.</li> <li>– Always use the lifting points provided to move the machine/machine sections.</li> <li>– Always use the designated load take-up point.</li> </ul> </li> </ul>

	 <b>WARNING</b>
	<ul style="list-style-type: none"> <li>• <b>Securing transit routes</b> <ul style="list-style-type: none"> <li>– The supply routes must be cleared prior to transport, and must be suitable for the forklift truck to pass through. If necessary, warning signs or barrier tape must be set up to keep the routes clear.</li> </ul> </li> <li>• <b>Caution</b> <ul style="list-style-type: none"> <li>– When opening transport boxes, care must be taken to ensure that any additional components delivered in the same box, such as computers, do not fall out.</li> </ul> </li> </ul>

	 <b>WARNING</b>
	<ul style="list-style-type: none"> <li>• <b>Danger of crushing for hands/feet</b> <ul style="list-style-type: none"> <li>– It is not permitted to grip onto or under the feet when handling the machine, as there is an increased risk of hands or feet getting crushed or trapped in these areas.</li> <li>– When setting down the station, make sure no persons have their feet under the machine's feet.</li> </ul> </li> </ul>

<b>NOTE</b>	
	<ul style="list-style-type: none"><li>– When opening the transport box, any additional components must be secured to prevent them from falling out, and removed first.</li><li>– Once this is done, the transport box can be removed/opened up fully, and the station can be taken out and moved to its intended location.</li><li>– Care must be taken with all components projecting from the machine, as sensors and similar small parts can easily be damaged if the machine is not transported correctly.</li><li>– Check that all the profile connectors are seated correctly using a size 4 – 6 Allen key. Unavoidable vibrations can loosen the connectors during transport.</li></ul>

## 6.2 Overview of the System

CP Lab Conveyor, CP Factory Linear, CP Factory Shunt and CP Factory Bypass are called basic modules. If an application module, e.g. the CP Application Module muscle press is attached to a basic module, it becomes a station.

### Example

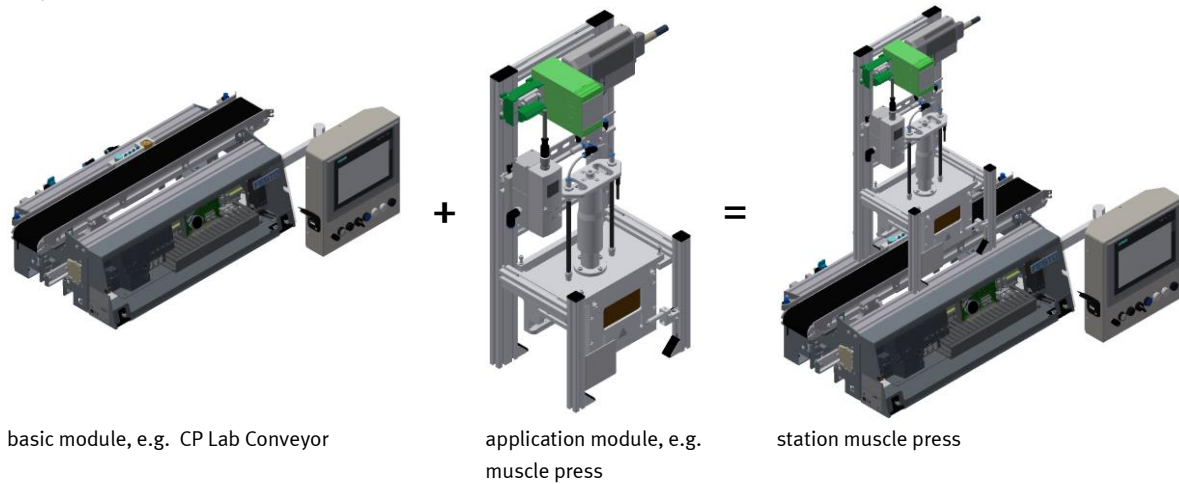

If several stations are put in a row one behind the other, this will form a production line.

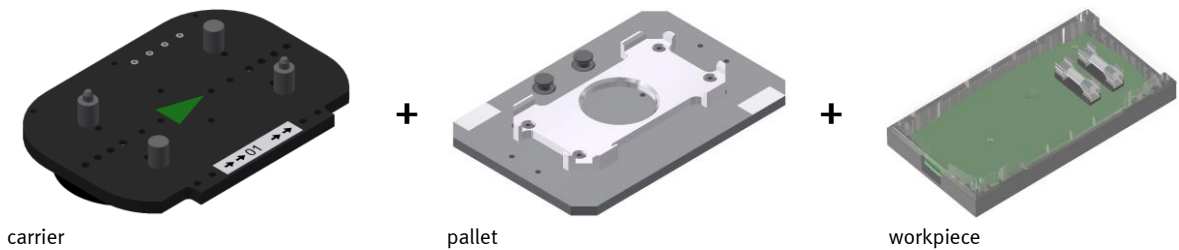

Carriers are transported on the conveyors of the basic modules. And on the carriers, there are pallets with a fixed workpiece reception placed. The workpieces are placed on the workpiece reception or taken from it. Pallets can also be placed on a carrier in some stations or gripped from there.

The typical workpiece of a CP Factory/Lab System is the roughly simplified version of a mobile phone. The workpiece consists of a front cover, of a back cover, of a board and of a maximum of two fuses.

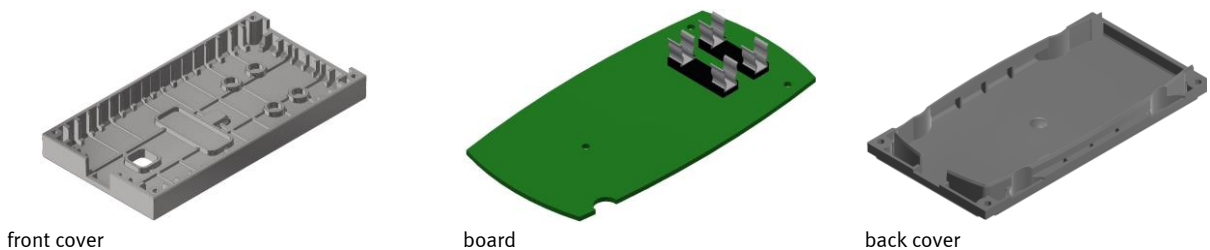

### 6.3 The application module camera inspection

The application module camera inspection designed for

- checking a board's equipment with fuses

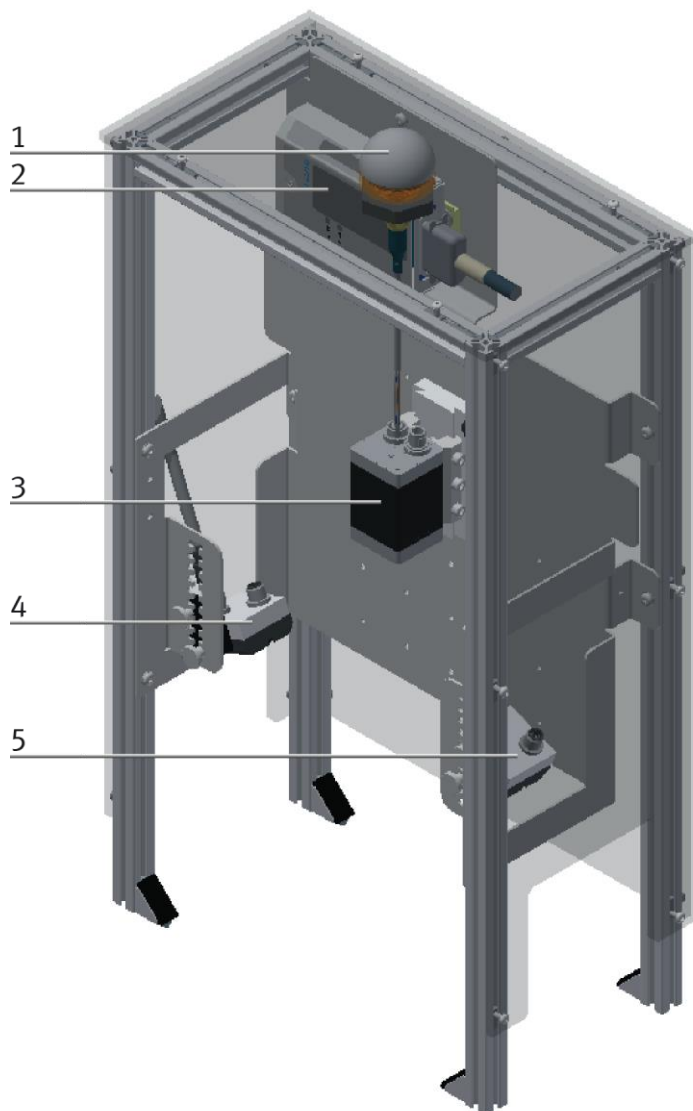

Illustration similar

Pos	Description	Name	Order Number
1	Pro indicator Banner	K50L2RGB7Q	8125590
2	I/O Module		8027412
3	Camera (Sensopart V20C-ALL-P3-W-M-M2-L-90)	SBSA-U-PF-R2C-FM-W	8143672
4	Light	SBAL-C6-A-W	8031158
5	Light	SBAL-C6-A-W	8031158

#### **6.4 Function**

The application module camera inspection checks if there are fuses on a board. The carriers are stopped when running into the application module. The camera takes a picture. The selected program will be executed and compared with the picture. The result will be processed, and the carrier with the workpiece will leave the application module.

#### **6.5 Sequence description**

##### **Start Conditions**

- All connections have been established properly.
- The camera has been started.

##### **Sequence**

1. If a carrier runs into the stopper unit, the stopper is in its extended position and the carrier is stopped.
2. The camera takes a picture.
3. The selected program will be executed for comparing the picture with the desired condition.
4. The result will be processed and passed on.
5. The stopper of the stopper unit drives downward, and the carrier leaves the application.



## 6.6 Electrical Connections

### 6.6.1 Overview

#### Connection with syslink connectors

The application module is connected to the electrical board of the module via I/O. The I/O module (1) of the application module is connected to the I/O terminal (2) on the module's electrical board.

#### 6.6.2 Profinet connections

The camera (3) of the application is connected via profinet to the switch (4) on the electrical board of the module.

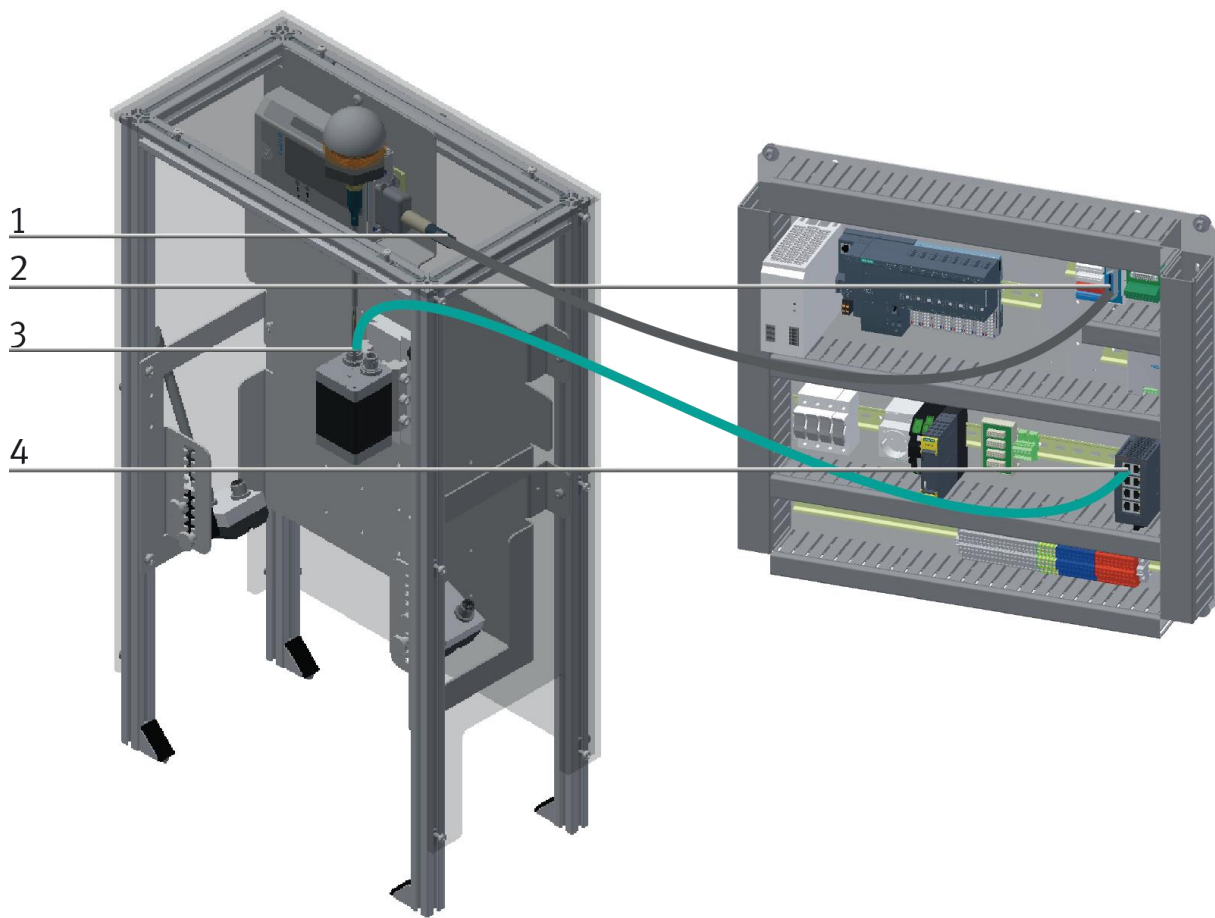

Electrical connection / illustration similar

### 6.6.3 I/O Module XD1



Illustration similar

#### Inputs PLC / outputs camera

Designation	Equipment identifier	Application	Application SysLink
Ready		XD1 / XK: I0	XD1:XS13
Valid		XD1 / XK: I1	XD1:XS14
LED A		XD1 / XK: I2	XD1:XS15
LED B		XD1 / XK: I3	XD1:XS16
LED C		XD1 / XK: I4	XD1:XS17
Lighting		XD1 / XK: I5	XD1:XS18
Reserve		XD1 / XK: I6	XD1:XS19
Reserve		XD1 / XK: I7	XD1:XS20

**Outputs PLC / Inputs camera**

Designation	Equipment identifier	Application	Application SysLink
Trigger		XD1 / XK: 00	XD1:XS1
Input		XD1 / XK: 01	XD1:XS2
Encoder A		XD1 / XK: 02	XD1:XS3
Encoder B		XD1 / XK: 03	XD1:XS4
Basecolor red PF1	=B+BX-P1-PF1	XD1 / XK: 04	XD1:XS5
Basecolor green PF2	=B+BX-P1-PF2	XD1 / XK: 05	XD1:XS6
Basecolor blue PF3	=B+BX-P1-PF3	XD1 / XK: 06	XD1:XS7
Flashing FL	=B+BX-P1-FL	XD1 / XK: 07	XD1:XS8

**Display LED lamp**

Color	Display color						
	RD	YE	GN	CY	BU	MA	WH
PF1: red	●	●				●	●
PF2: green		●	●	●			●
PF3: blue				●	●	●	●

## 7 Commissioning

	<b>NOTE</b>
	<ul style="list-style-type: none"> <li>– The following applies to the start-up as well as to the restart.</li> </ul>

- The CP Application Module is delivered pre-assembled.
- All attachment parts are individually packaged.
- All components, tubings and cabling have been clearly marked in order to guarantee a problem-free retrieving of all connections.
- For the operation within a CP Factory/Lab System, the CP Application Module has to be put on and attached to a basic module.

	<b>NOTE</b>
	<ul style="list-style-type: none"> <li>– You can read the general installation instructions in the manual of your basic module. The following instructions apply particularly to the CP Application Module.</li> </ul>

### 7.1 Workplace

The commissioning of the CP Application Module requires:

- a CP Application Module
- a basic module CP Factory or a basic module CP Lab Conveyor for the installation of the CP Application Module
- a SysLink cable for the connection between the I/O terminal of the CP Application Module and the basic module CP Factory
- an Ethernet cable for the connection of the motor controller (option)
- an on-site electrical connection in the room, see data sheet basic module
- an on-site pneumatically connection in the room, see data sheet basic module

## 7.2 Visual Inspection

	 <b>WARNING</b>
	<ul style="list-style-type: none"><li>• <b>Any damages must always be repaired instantly.</b></li></ul>

Visual inspection has to be carried out prior to every commissioning!

Before you start the CP Application Module, you must always inspect the following parts regarding visual damages and function:

- Electrical connections
- Mechanical components and connections
- Emergency Stop devices

## 7.3 Safety Regulations

	 <b>WARNING</b>
	<ul style="list-style-type: none"><li>• <b>Any damages must always be repaired instantly.</b></li></ul>

The CP Application Module may only be operated on the following conditions:

- The technical condition – mechanically and electrically – of the CP Application Module is perfect.
- The CP Application Module is used in accordance with the regulations.
- The operating instructions have been read and understood.
- All safety devices are available and active.

### 7.4 Assembly

The application module is mounted on the basic module with the following distance (see picture): the distance between the stopper edge and the profile edge is the same with a CP-Lab conveyor as with a CP-Factory basic module.

The assembly process is explained in the following chapter as an example. The displayed dimension is an approximation, it is possible that a fine adjustment is necessary for error-free processing.

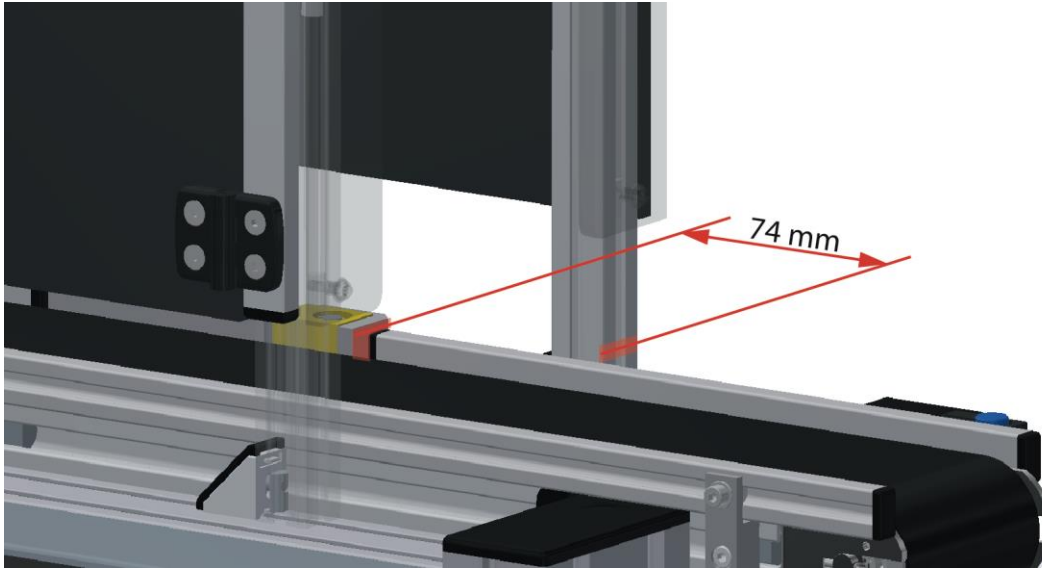

Example distance between application module and stopper / illustration similar

#### 7.4.1 Assembly of an CP application module

	<b>NOTE</b>
	<p>The procedure of attaching the CP application module to a basic module is the same as with all basic modules. The following description for the attachment to a basic module. CP Lab Conveyor is an example for all basic modules and all application modules.</p>

### Positioning slot nuts in the cross profiles of the basic module CP Lab Conveyor

Mounting the CP application module is very easy:

- Two M5-slot nuts (2) have to be put into the inner front slot of the cross profile (4) of the basic module CP Lab Conveyor.
- Then put two additional M5-slot nuts (2) into the inner back slot of the cross profile (3) of the basic module CP Lab conveyor.
- Then you have to position the slot nuts (2) approximately to the distance of the vertical cross profiles of the CP application module.

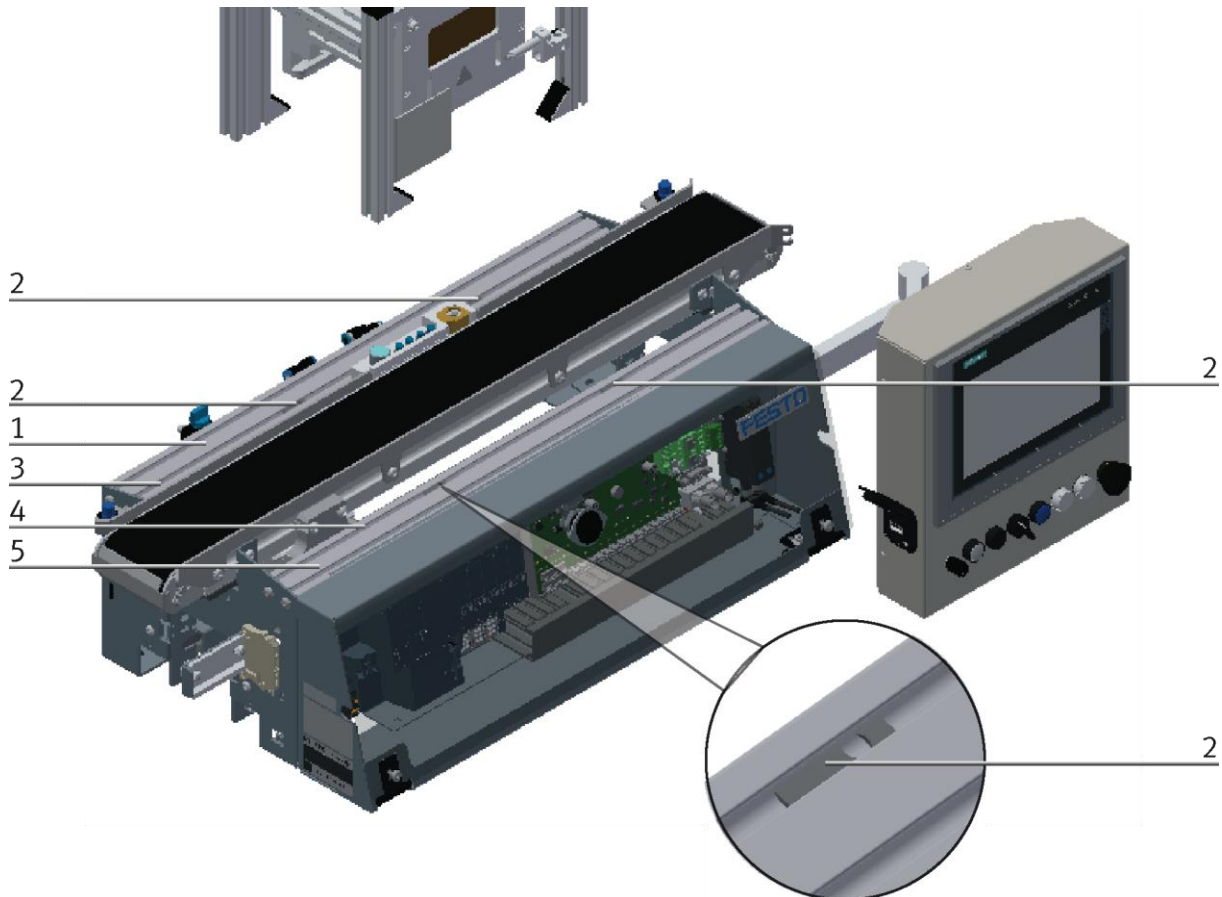

Positioning slot nuts / illustration similar

Position	Description
1	back cross profile
2	slot nut
3	Inner slot (back cross profile)
4	Inner slot (front cross profile)
5	front cross profile

**Attaching the application module to the basic module CP Lab Conveyor**

- Put the CP application module on the basic module CP Lab Conveyor.
- Position the slot nuts (2) underneath the mounting brackets (1) of the CP application module so that the internal threads of the slot nuts are visible underneath the elongated holes of the mounting brackets.

	<b>NOTE</b>
	Use Allen keys for lateral adjustment of the slot nuts.

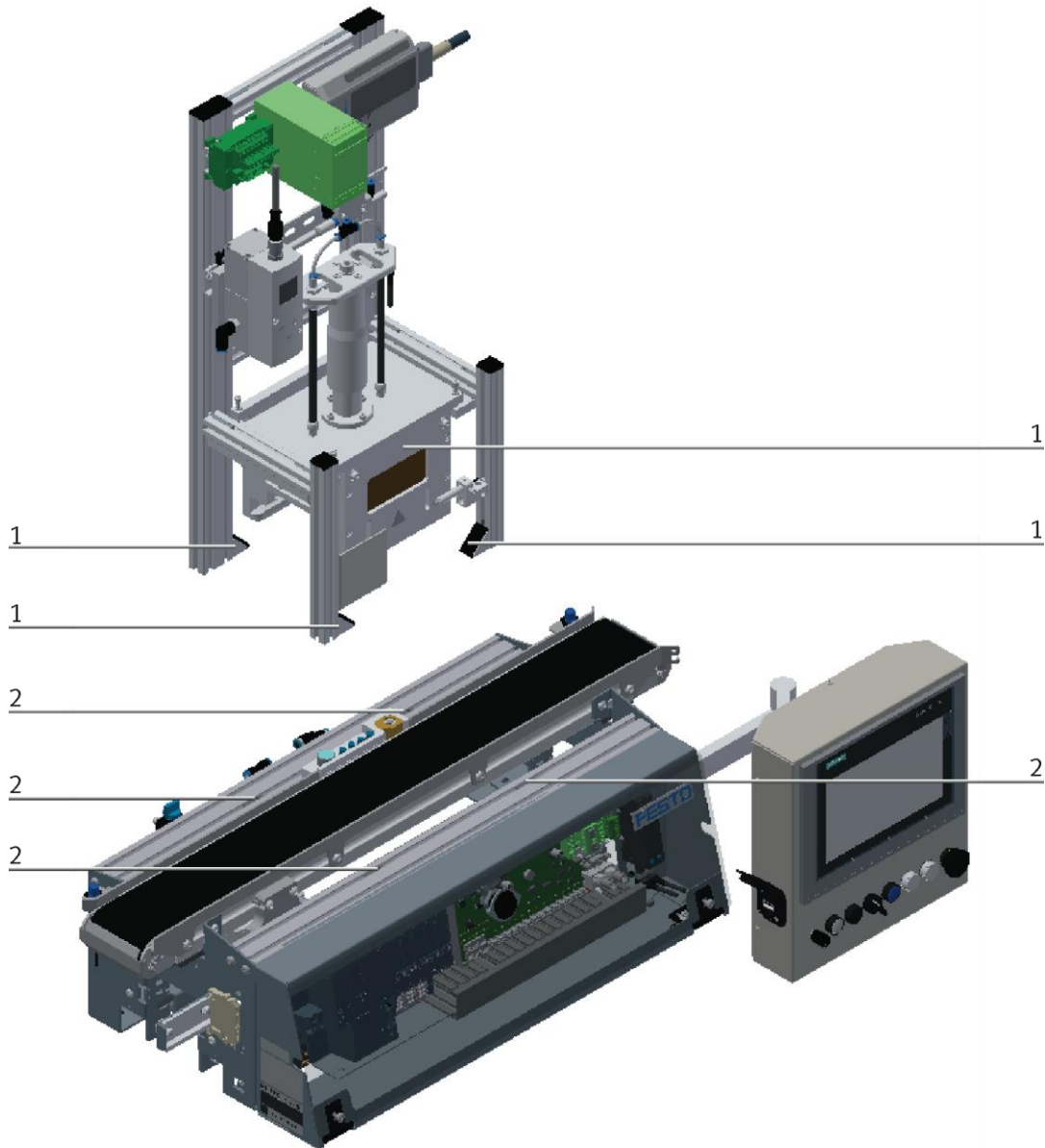

How to put on the CP application module / illustration similar

Position	Description
1	CP application module: mounting bracket
2	slot nut



### Adjusting the CP application module and fixing it on the basic module CP Lab Conveyor

- Use raised head screws M5x8, in order to connect the mounting brackets (1) of the CP application module Measuring, at first loosely, with the cross profiles (2) of the basic module CP Lab Conveyor.
- After setting all raised head screws, you can still move the CP application module to the position required.
- Push a carrier with pallet and front cover to the stopper position. The front cover points with its inside upwards. The drilled hole of the front cover is on the left side.
- Have a visual inspection to make sure that the two distance sensors are capable of registering the front cover more or less in medium range.
- Now tighten the raised head screws.
- Then put the black covers onto the mounting brackets.

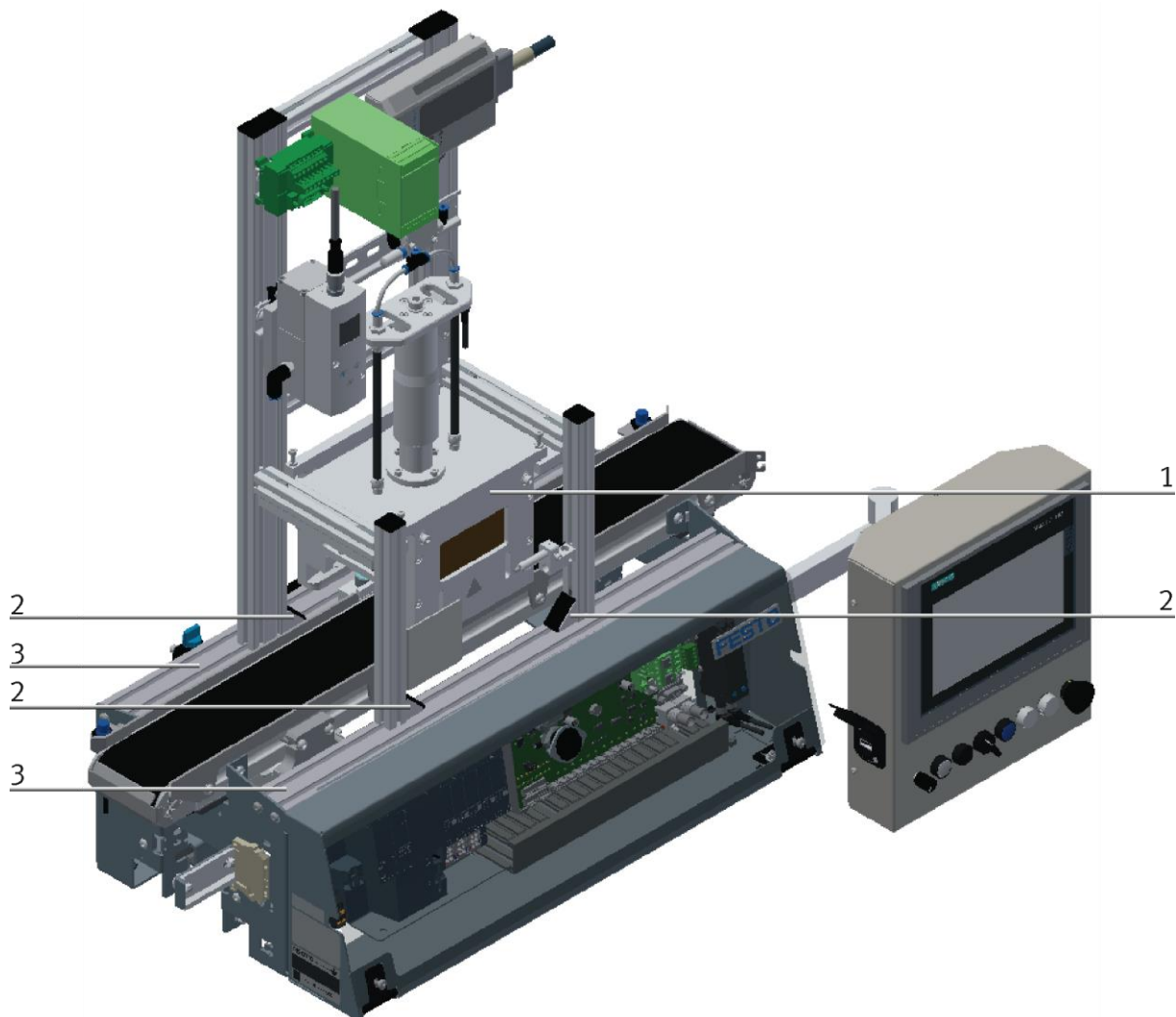

Tightening the CP application module / illustration similar

Position	Description
1	CP application module: mounting bracket with cover
2	basic module CP Lab Conveyor: cross profile

## 7.4.2 Connecting the CP application module electrically to basic module CP Lab Conveyor SysLink-interface for digital signals

	<p style="text-align: center;"><b>NOTE</b></p> <p>With special variants of the basic module CP Lab Conveyor, you absolutely have to observe the corresponding operation instructions of the basic module CP Lab Conveyor!</p>
---	---

The CP application module exchanges digital input and output signals with the basic module via the SysLink interface:

- Connect the I/O terminal (1) of the CP application module with the control (6) of the basic module CP Lab Conveyor. Therefore use the connecting cable with SysLink plugs (3) which has already been attached to the control and is led out on the back side of the basic module CP Lab Conveyor.

### **D-Sub-interface for analogue signals (option – not available at all application modules)**

The CP application module muscle press provides an analog output signal. This must be applied to the analog terminal (2) and connected to the analog inputs of the basic module:

- Connect the analog terminal (2) of the CP application module to the D-Sub interface for analog signals (5) on the XZ1 board of the CP Lab Band basic module. For this purpose, use the supplied connection cable (4) with standard D-Sub connectors: 15-pin, double row.

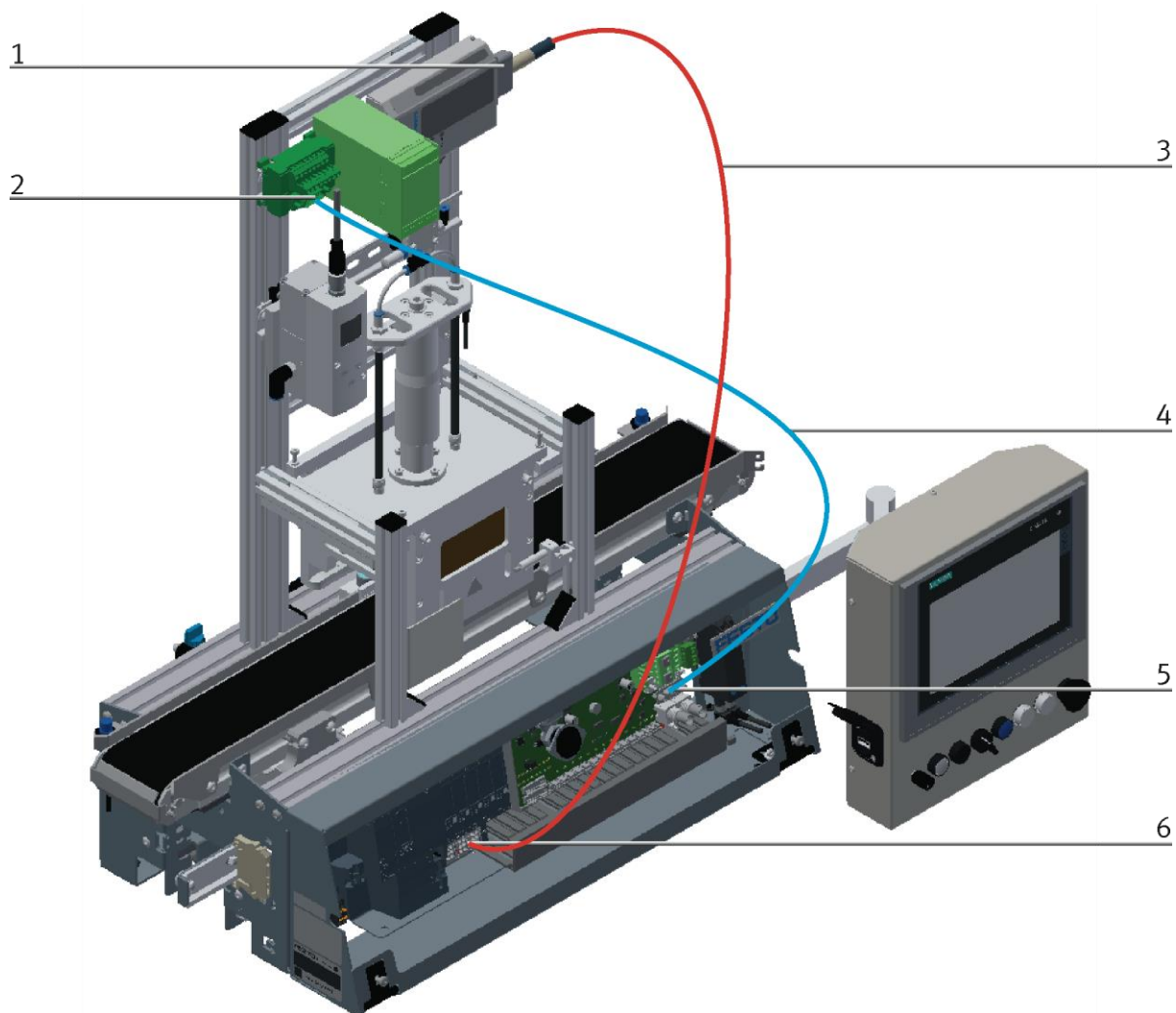

Electrical connections / illustration similar

Position	Description
1	CP application module: I/O terminal (+BG-XD1)
2	CP application module: analogue terminal (+BG-XD2A)
3	connecting cable with a SysLink-plug (SysLink-cable)
4	connecting cable with 15-pin standard D-Sub-plugs
5	basic module CP Lab Conveyor: board (XZ1 / X5)
6	Basic module CP Lab Band: PLC (-inputs / KF2; outputs / KF4)

**7.4.3 Pneumatic connection from application modules (option – not available at all application modules)**

The pneumatic connection is made according to the principle of the following sketch. The application module is connected from the valve terminal/valve (2) to the shut-off valve (4) on the conveyor belt. The hose (3) (nominal diameter 4) is simply plugged into the QS connector. The supply line (1) is plugged into the T-connector (5); the CP Lab conveyor is also supplied from this T-connector (6).

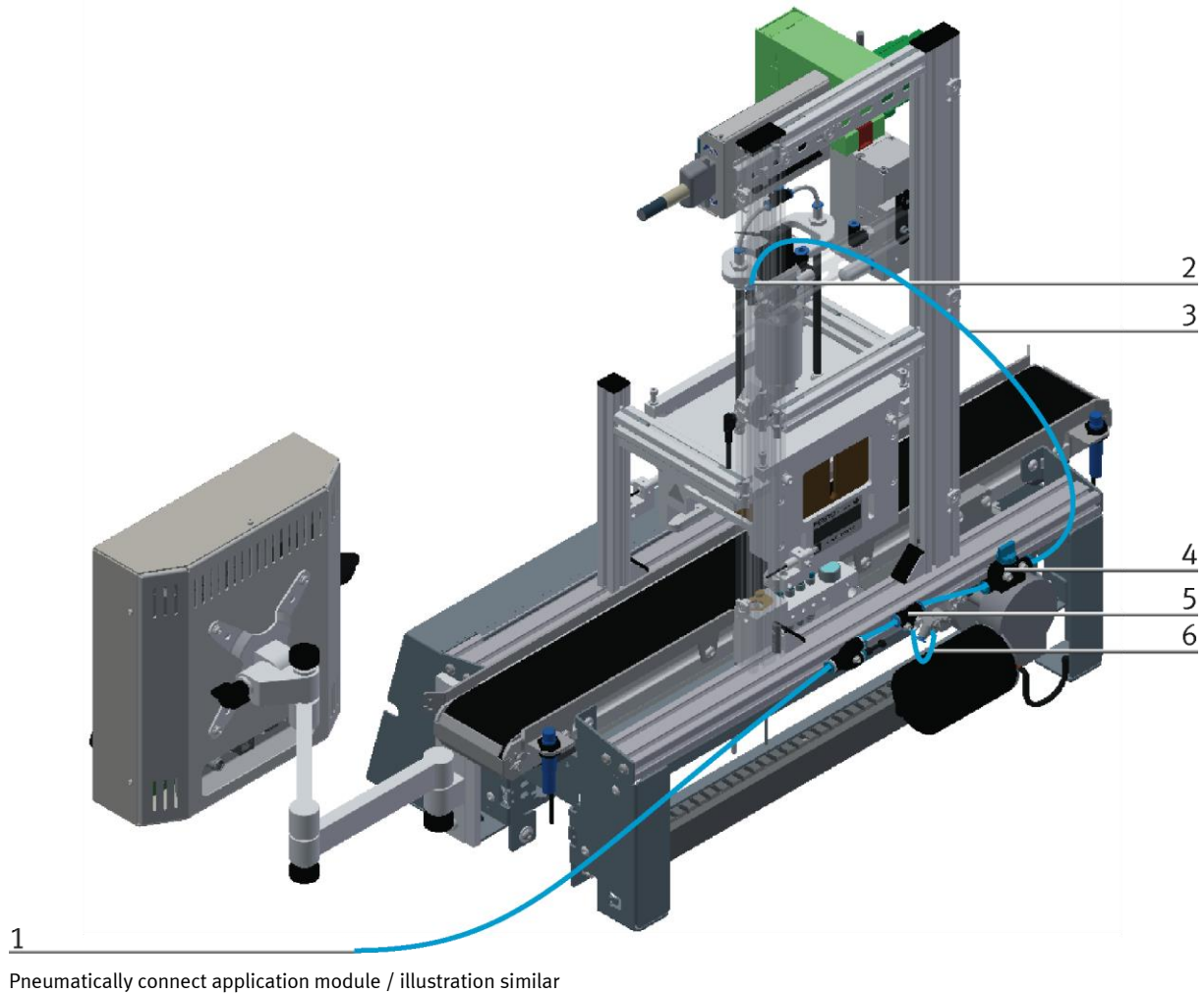

#### 7.4.4 Assembly of an CP application module to a CP Factory basic module

	NOTE
<p>The procedure for installing a CP application module on a basic module is identical for all basic modules. The following example is an example for all basic modules and applications.</p>	

##### Positioning slot nuts in the cross profiles of the CP Factory basic module

Mounting the CP application module is very easy:

- Two M5-slot nuts (1) have to be put into the inner front slot of the cross profile (4) of the CP Factory basic module.
- Then put two additional M5-slot nuts (1) into the inner back slot of the cross profile (2) of the basic module.
- Then you have to position the slot nuts (1) approximately to the distance of the vertical cross profiles of the CP application module.

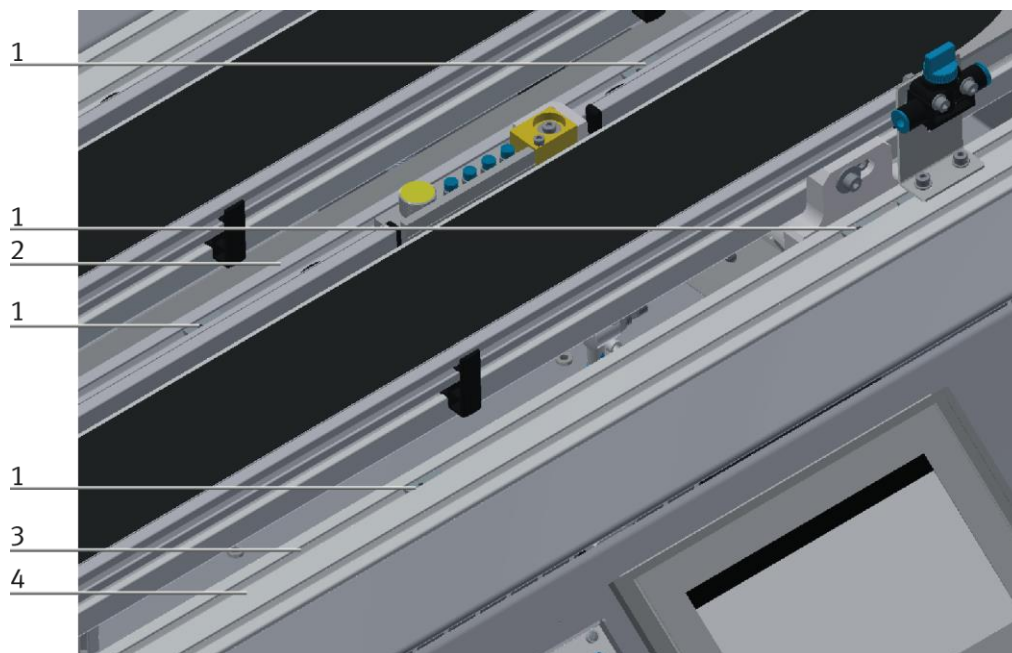

Positioning slot nuts / illustration similar

Position	Description
1	slot nut
2	back cross profile
3	Inner slot (front cross profile)
4	front cross profile

**Attaching the application module to the CP Factory basic module**

- Put the CP application module on the CP Factory basic module.
- Position the slot nuts (2) underneath the mounting brackets (1) of the CP application module so that the internal threads of the slot nuts are visible underneath the elongated holes of the mounting brackets.

	<b>NOTE</b>
	Use Allen keys for lateral adjustment of the slot nuts.

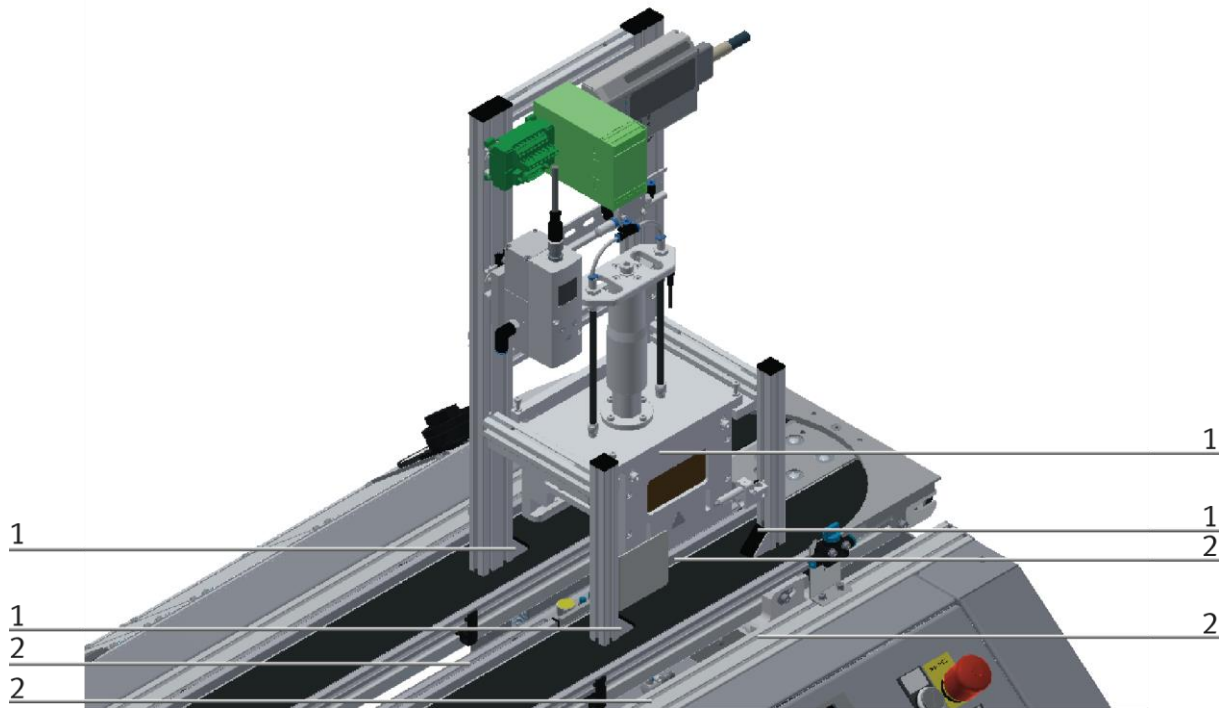

How to put on the CP application module / illustration similar

Position	Description
1	CP application module: mounting bracket
2	slot nut

### Adjusting the CP application module and fixing it on the CP Factor basic module

- Use raised head screws M5x8, in order to connect the mounting brackets (1) of the CP application module Measuring, at first loosely, with the cross profiles (2) of the CP Factory basic module.
- After setting all raised head screws, you can still move the CP application module to the position required.
- Push a carrier with pallet and front cover to the stopper position. The front cover points with its inside upwards. The drilled hole of the front cover is on the left side.
- Have a visual inspection to make sure that the two distance sensors are capable of registering the front cover more or less in medium range.
- Now tighten the raised head screws.
- Then put the black covers onto the mounting brackets.

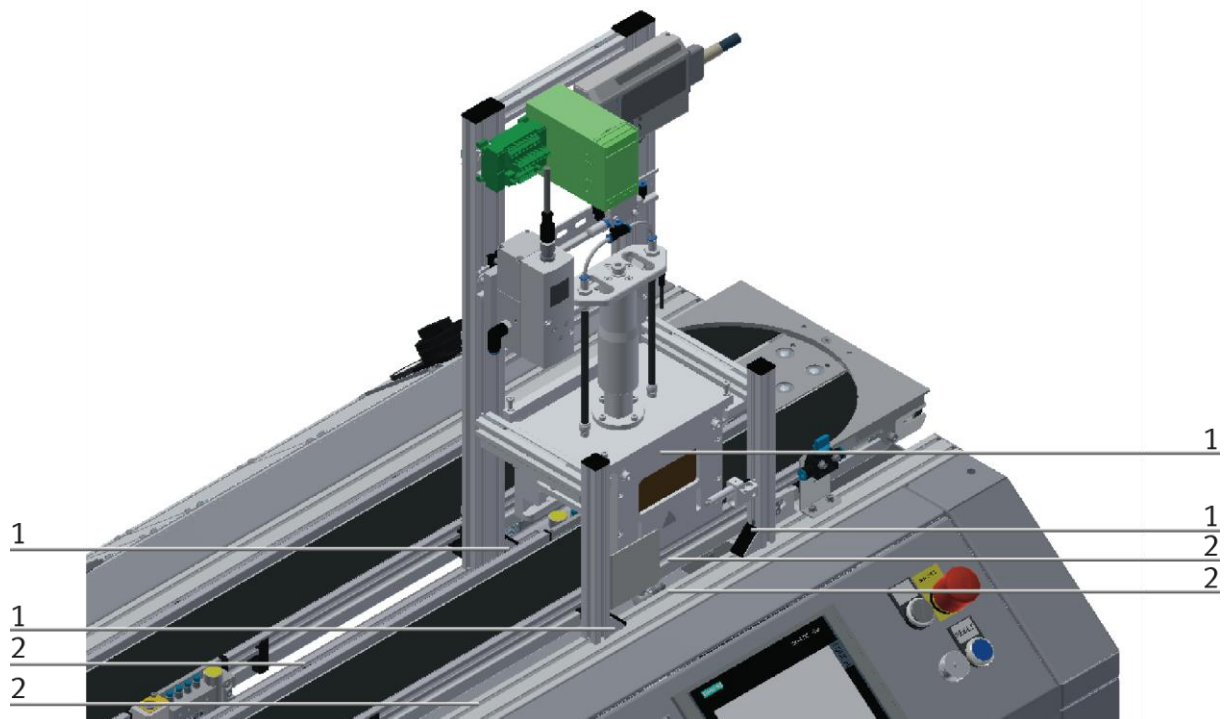

Tightening the CP application module / illustration similar

Position	Description
1	CP application module: mounting bracket with cover
2	CP Factory basic module: cross profile



### 7.4.5 Connecting the CP application module electrically to the CP Factory basic module

#### SysLink-interface for digital signals

The CP application module exchanges digital input and output signals with the basic module via the SysLink interface:

- Connect the I/O terminal (1) of the CP application module with the I/O terminal (6) on the electric board of the CP Factory basic module. Therefore use the provided connecting cable with SysLink plugs (5).

#### D-Sub-interface for analogue signals (option – not available at all CP application modules)

The CP application module produces two analogue output signals with the distance sensors. These are set on the analogue terminal and have to be connected with the analogue inputs of the CP Factory basic module:

- Connect the analogue terminal (2) of the CP application module with the analogue terminal (4) on the electric board of the CP Factory basic module. Therefore use the provided connecting cable (3) with standard D-Sub plugs: 15-pin, two-rowed.

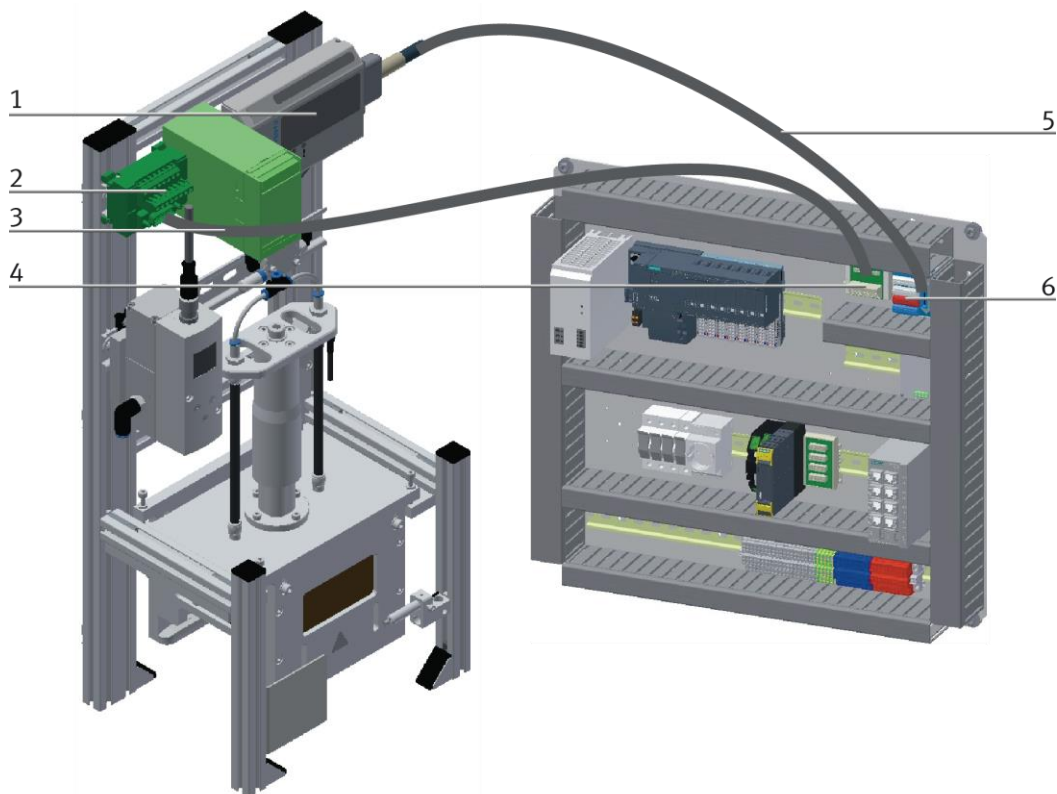

Electrical connections / illustration similar

Position	Description
1	CP application module: I/O terminal (+BG-XD1)
2	CP application module: analogue terminal (+BG-XD2A)
3	connecting cable with 15-pin D-Sub-plugs
4	electric board CP Factory basic module: analogue terminal (+K1-XD16A)
5	connecting cable with SysLink-plugs (SysLink-cable)
6	electric board CP Factory basic module: I/O terminal (+K1-XD15)



### 7.4.6 Stand alone operation

So that you can work with the application module camera inspection without a conveyor, there are two safety sockets (1) for the power supply on the back of the module. A maximum voltage of 24 V may be applied to these sockets. In this case, the I/O module must not be connected.

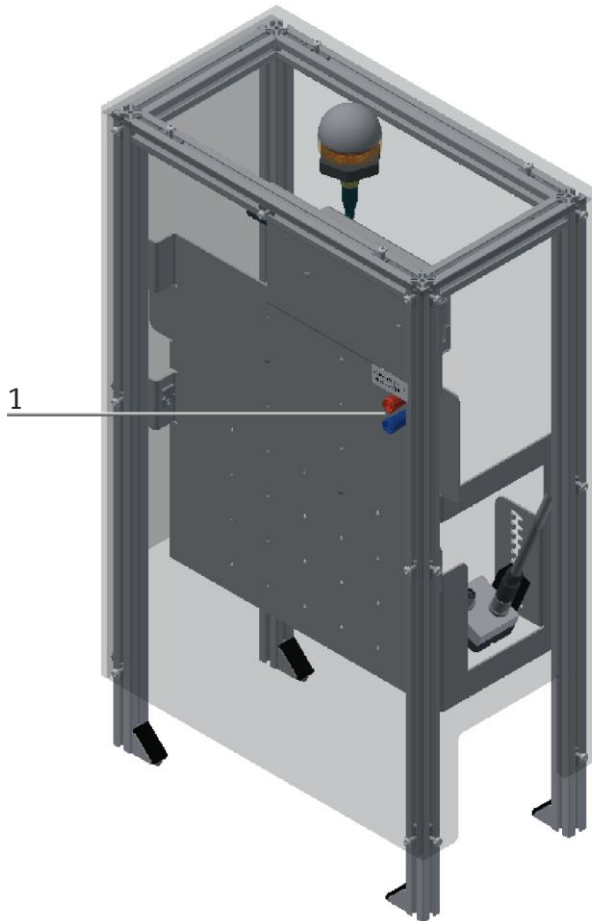

## 8 Operation

An application module has no control elements. Operation of the application module is only possible when it is mounted on a basic module of the CP-Lab or CP-Factory system.

The operation of the application module can be realized by every customer according to his wishes, the supplied programs are only an operating suggestion with which the application module is on CP-Lab or CP-Factory System can be operated. Own operating concepts or external controls are also possible.

If the application module is mounted on a CP Lab or a CP Factory basic module, the general operation for this is described in the manuals of the CP Lab or CP Factory system. All application-specific information is described in this manual for the application module.

1. The manual for the camera, the brief description, the communication manual and the product catalog are included with the operating instructions as accompanying documents.

### 8.1 Setting the application module magazine at HMI

To set the application module, the application module must be set to setup mode.

1. Since the application module does not have any actuators that require a home position travel, it does not have to be set. On the home screen, select Setup under Operating mode, setup mode is active.

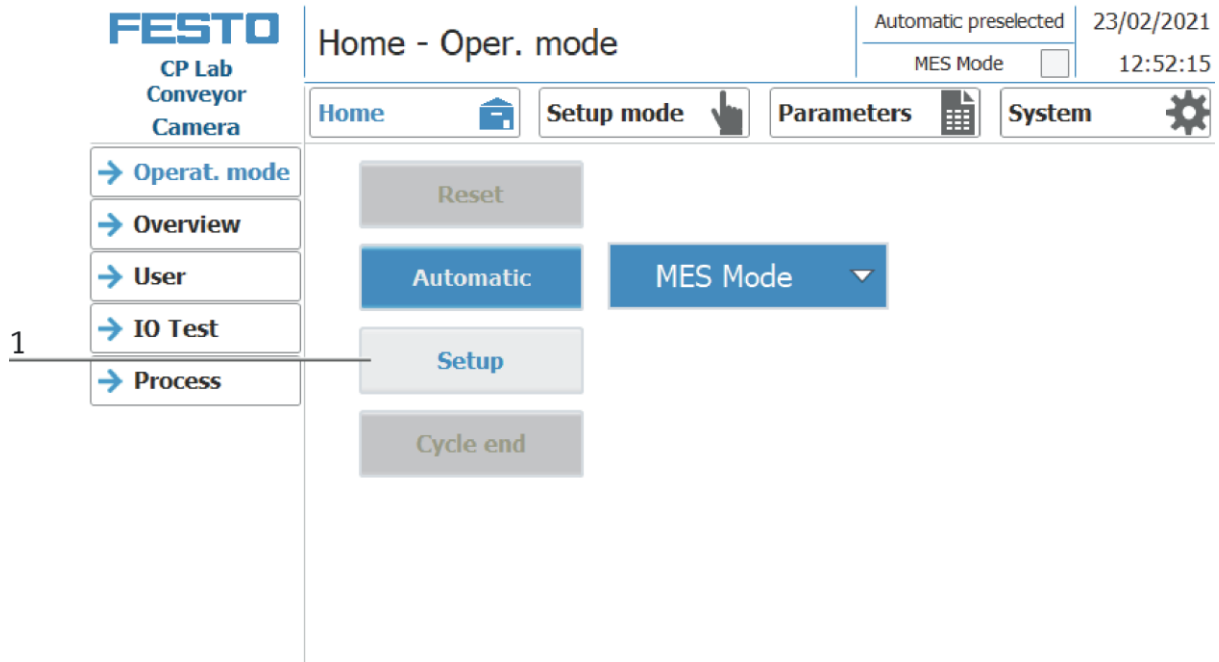

- Change to Setup mode page.

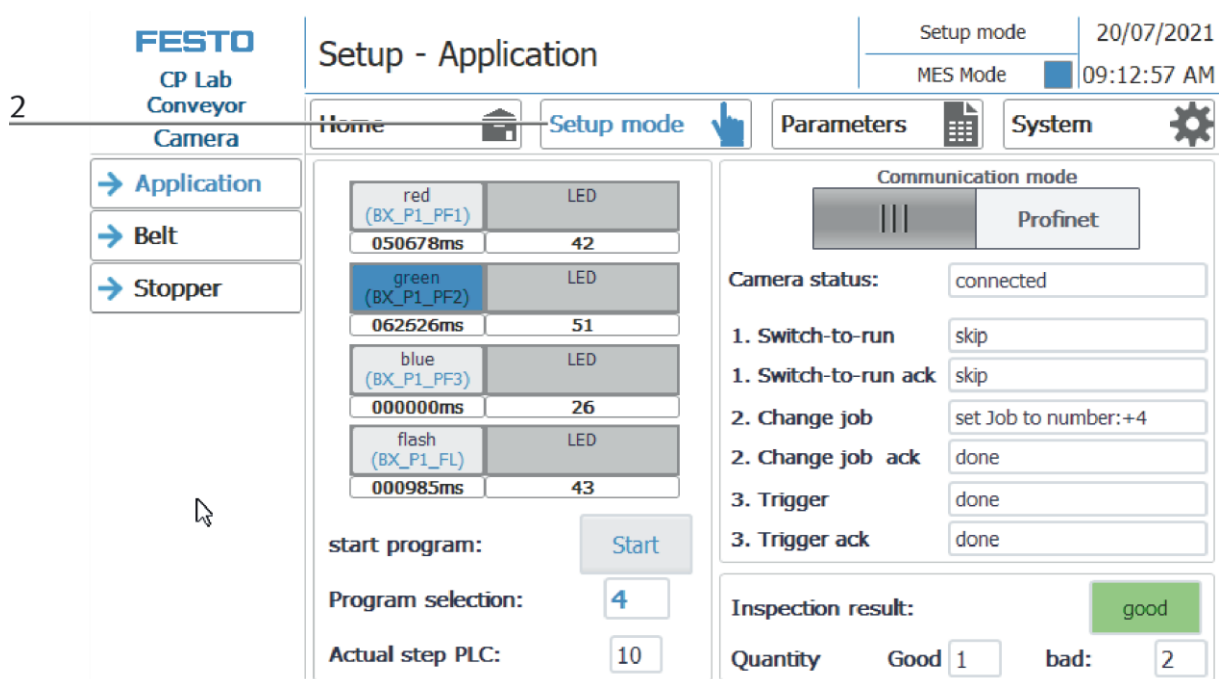

- The application is already selected in order to set up the application module or to operate it manually. The corresponding actuators can be controlled by pressing the buttons. The status of the camera is displayed and predefined test programs can be started.

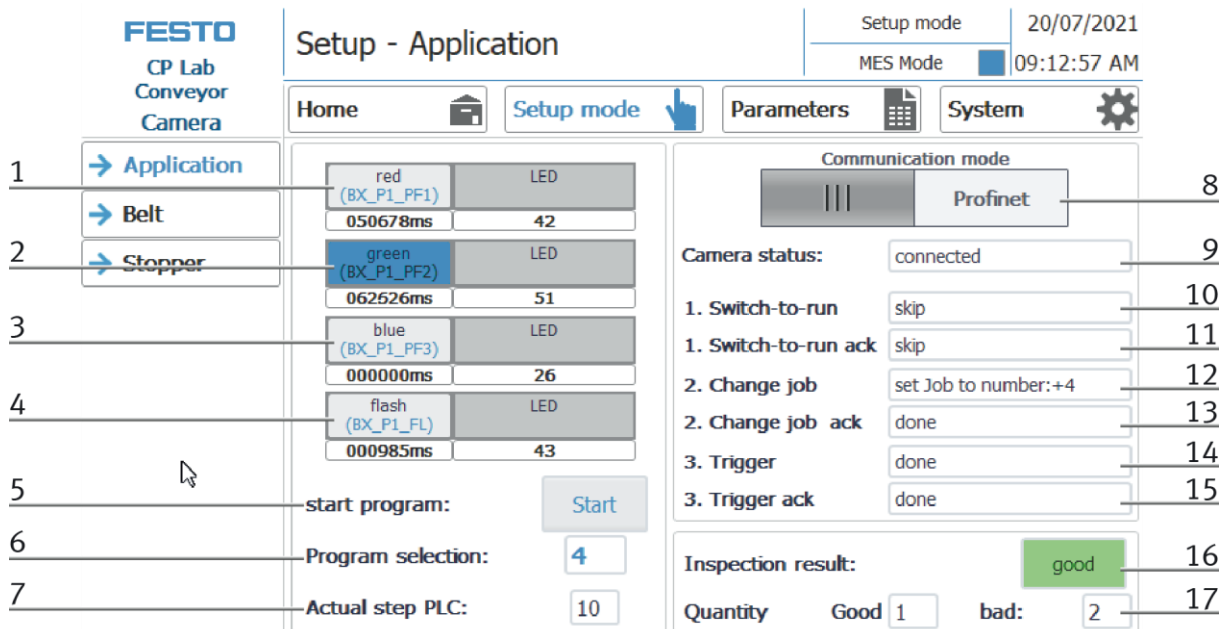

Position number	Description
1	Activate the multicolor LED basic color red Red button: Activate the basic color red (actuator BX_P1_P1 is activated, button has a blue background)
2	Activate the multicolor LED basic color green Green button: Activate the basic color green (actuator BX_P1_P2 is activated, button has a blue background)
3	Activate the multicolor LED basic color blue Blue button: Activate the basic color blue (actuator BX_P1_P3 is activated, button has a blue background)
4	Activate multicolor LED flashing Flashing button: Let the LED flash (actuator BX_P1_FL is activated, button has a blue background)
5	Start program: the selected camera program can be started here.
6	Selection program: the measuring programs of the camera are selected here 1: Check: circuit board present, no fuse installed 2: Check: circuit board present, front fuse installed (viewed in the direction of transport) 3: Check: circuit board present, rear fuse installed (viewed in the direction of transport) 4: Check: circuit board present, both fuses installed 5: Check: workpiece orientation correct in running direction (rotation around Z-axis)
7	Display the current step of the camera control module in the PLC
8	Display and selection of the communication mode: Profinet or OPC UA  Profinet: The camera is directly connected to the PLC via PROFINET, whereby the PLC represents the PROFINET controller and the camera a PROFINET device. OPC UA: The camera is connected to an KI computer, the PLC communicates with the KI computer via OPC UA (PLC: OPC UA server, KI computer OPC UA client)
9	Camera status: Display of the connection status of the PLC to the camera or to the OPC UA client
10	Display of the 1st step: Switch-to-run (activate control)
11	Display of confirmation of step 1: Switch-to-run ack
12	Display of the 2nd step: Change job (job switching)
13	Display of the confirmation of the 2nd step: Change job ack
14	Display of the 3rd step: Trigger (trigger recording and evaluation)
15	Display of the confirmation of the 3rd step: Trigger ack
16	Inspection result: the result of the last recording and evaluation is displayed here
17	Number of tested parts: the number of all good and bad parts since switching on are displayed here

### 8.2 Transitions of the application module

The transitions are located in the Parameters submenu

Parameters - Transitions

Automatic mode 23/02/2021  
Default Mode 12:45:10

Home Setup mode Parameters System

→ Application  
→ **Transitions**  
→ Belt, Stopper

No.	Start condition	Application execute	Prog.No.	Parameter			End condition	
				Parameter 2	Parameter 3	Parameter 4	OK	NOK
Init		<input type="checkbox"/>	0	0	0	0	0	0
1	500	<input checked="" type="checkbox"/>	4	0	0	0	600	0
2	0	<input type="checkbox"/>	0	0	0	0	0	0
3	0	<input type="checkbox"/>	0	0	0	0	0	0
4	0	<input type="checkbox"/>	0	0	0	0	0	0
5	0	<input type="checkbox"/>	0	0	0	0	0	0
6	0	<input type="checkbox"/>	0	0	0	0	0	0
7	0	<input type="checkbox"/>	0	0	0	0	0	0
8	0	<input type="checkbox"/>	0	0	0	0	0	0
9	0	<input type="checkbox"/>	0	0	0	0	0	0
10	0	<input type="checkbox"/>	0	0	0	0	0	0

If the transitions submenu is selected, the transitions of the mounted application module are displayed. The transitions of all other application modules can be found in the corresponding manuals of the application modules.

1. Click on the gear wheel to access the settings for the transitions. (see the following picture)

### Settings of the transition table

**Initializing of the carriers**

State code on RFID at carrier infeed:  2

State code on RFID at carrier outfeed:  3

1  Initialize carrier.  with state code:  4

Number of carriers to initialize:  5

Already initialized carriers:  6

---

**Transition execution**

Checking start conditions again after application execution 7

8

Position number	Description
1	Initialize workpiece carrier: The next carrier arriving at the stopper position is initialized with the end state (state code can be entered under item 4) of the first line of the transition table.
2	Status code on the RFID at carrier infeed: Display of the start condition for application processing
3	Status code on the RFID at carrier outfeed: Display of the start condition after application processing
4	With state code: During initialization (Pos. 1 / Initialize carrier), the carrier is initialized with the state code entered here.
5	Number of carriers to be initialized: Editable, the number of workpiece carriers to be initialized can be entered here.
6	Already initialized carriers: Display of the already initialized workpiece carriers
7	Checking start conditions again after application execution: If this function is activated, the start conditions are checked again after a transition condition has been processed. In this way it is possible to execute an application several times without the carrier leaving the working position.
8	Exit settings

### 8.3 Process of the application module

1 **FESTO** CP Lab  
Conveyor Camera

Home - Process

Setup mode 20/07/2021  
Default Mode 09:08:46 AM

Home Setup mode Parameters System

2

Operat. mode  
Overview  
User  
IO Test  
Process

3

**PROFINET state**

xReady	xErrorBit0
xTriggerAck	xErrorBit1
xChangeJobAck	xErrorBit2
xSwitchToRunAck	xErrorBit3
xDigitalResult0	xTriggerMode
xDigitalResult1	xOpMode
xDigitalResult2	
xDigitalResult3	
xDigitalResult4	
xDigitalResult5	
usiJobNumber:	1
usiImageID:	5

**PROFINET control**

xResetError  
xHwTriggDisable  
xTrigger  
xChangeJog  
xSwitchToRun

usiJobNumber: 1

**PROFINET data bytes**

01	5	12	0	23	0
02	0	13	0	24	0
03	0	14	0	25	0
04	0	15	0	26	0
05	0	16	0	27	0
06	0	17	0	28	0
07	0	18	0	29	0
08	0	19	0	30	0
09	0	20	0	31	0
10	0	21	0	32	0
11	0	22	0	33	0

Position number	Description
1	<p>PROFINET status</p> <p>XReady camera is ready for the next evaluation</p> <p>xTriggerAck Confirmation for a successful trigger request</p> <p>xChangeJobAck Confirmation of the change job request that has been made</p> <p>xSwitchToRunAck Confirmation for the switch-to-run request that has been made</p> <p>xDigitalResult0 Bit 0 of the digital result (12 RDBU)</p> <p>xDigitalResult1 Bit 1 of the digital result (09 RD)</p> <p>xDigitalResult2 Bit 2 of the digital result (05 PK)</p> <p>xDigitalResult3 Bit 3 of the digital result (06 YE)</p> <p>xDigitalResult4 Bit 4 of the digital result (05 BK)</p> <p>xDigitalResult5 Bit 5 of the digital result (08 GY)</p> <p>The byte with the results of the digital outputs is defined in the VISOR software of the vision sensor in the Output / Output signals tab in SensorConfig</p> <p>xErrorBit0 Bit 0 of the 4-bit error code</p> <p>xErrorBit1 Bit 1 of the 4-bit error code</p> <p>xErrorBit2 Bit 2 of the 4-bit error code</p> <p>xErrorBit3 Bit 3 of the 4-bit error code</p> <p>0: No error</p> <p>1: Error trigger request (sensor not ready)</p> <p>2: Change job error</p> <p>3: Switch-to-Run error</p> <p>5: Error interface in job not active</p> <p>7: Focus lock time</p> <p>8: Archiving error</p> <p>15: System error</p> <p>xTriggerMode 0 = trigger</p> <p>1 = freewheel</p> <p>xOpMode 0 = configuration mode</p> <p>1 = run mode</p> <p>usiJobNumber: Number of the current job: Job number 1..255</p> <p>usiImageDI: Image ID (0..255); is increased by 1 each time a job is executed</p>
2	<p>PROFINET control</p> <p>xResetError Deletes the 4-bit error code in the status module; Rising edge clears the error code</p> <p>xHwTriggDisable Used to deactivate the trigger</p> <p>0 = trigger activated</p> <p>1 = trigger deactivated</p> <p>xTrigger Triggering the trigger with a rising edge (False True)</p> <p>xChangeJog Switch to job with number "Job number" with rising edge (False True)</p> <p>xSwitchToRun Operating mode change to Run with rising edge (False True)</p> <p>usiJobNumber Job number to be switched to on the rising edge of the change job bit. Binary value 1 255 for "Job number change". 0 stands for "no switchover", even if the Change.Job bit changes.</p>
3	<p>PROFINET data bytes - Depending on the hardware configuration of the PROFINET interface, the data bytes of the VISOR interface are displayed here.</p>



8.4 Flow chart

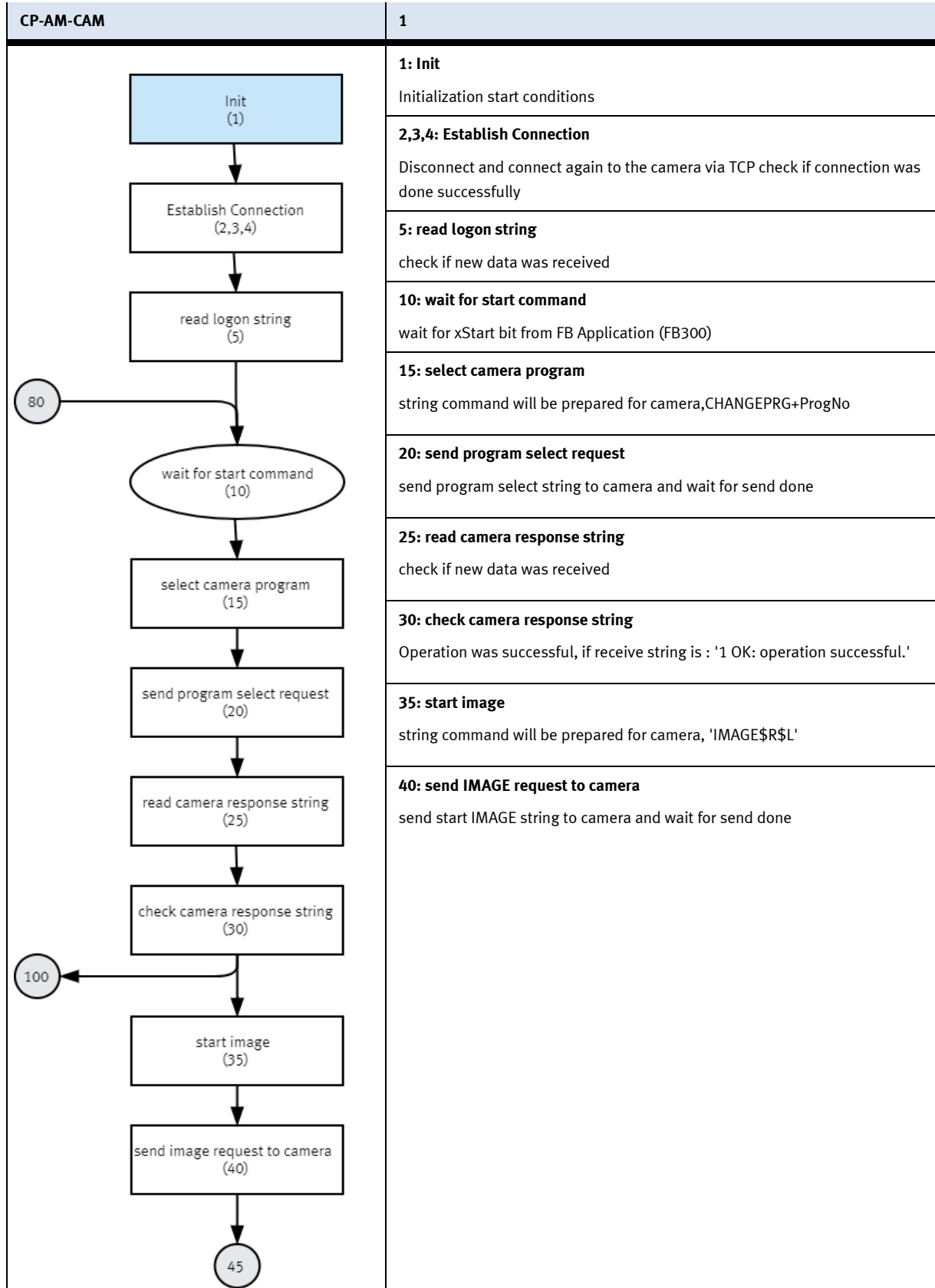

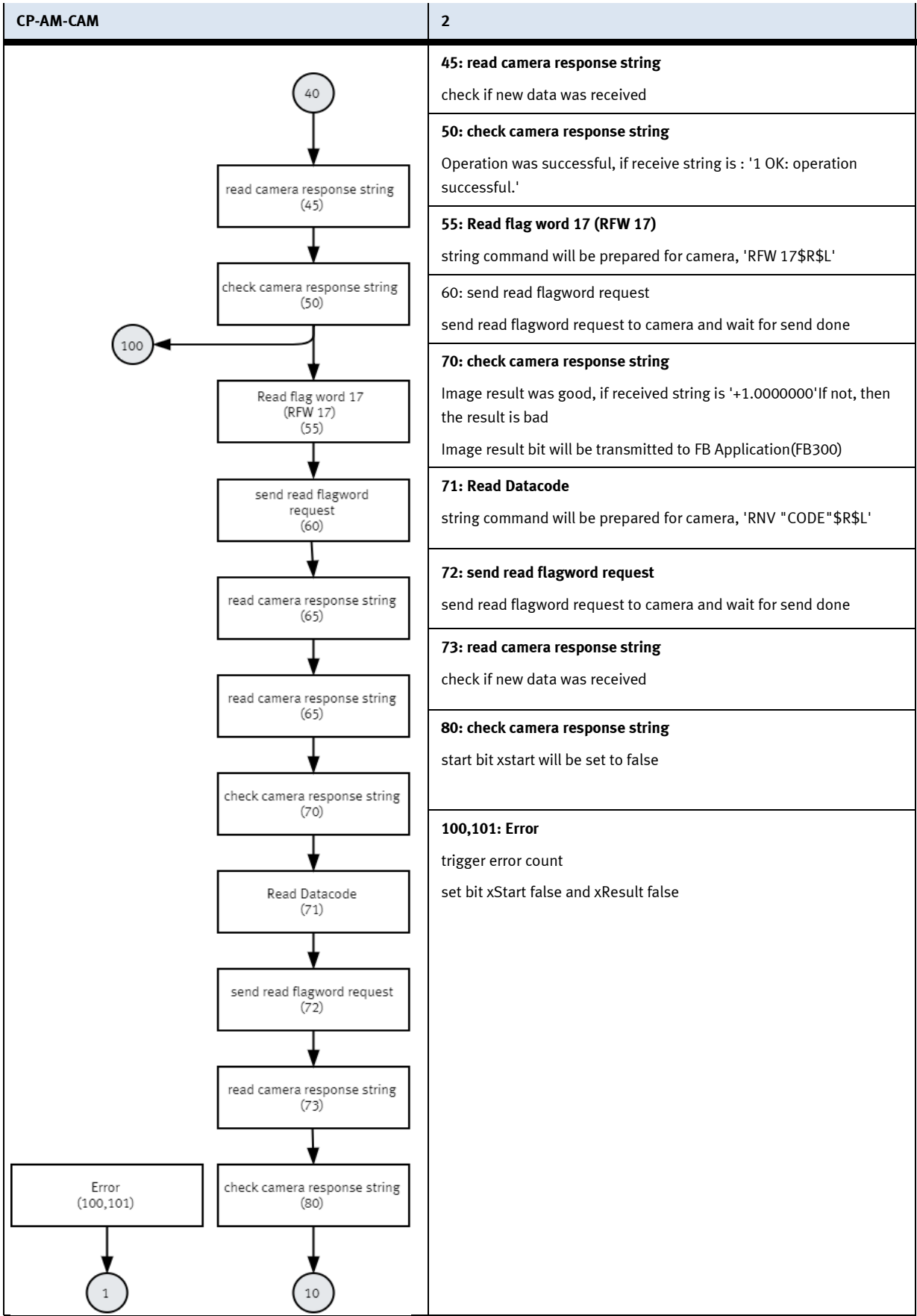

### 8.4.1 MES Parameter (CAM)

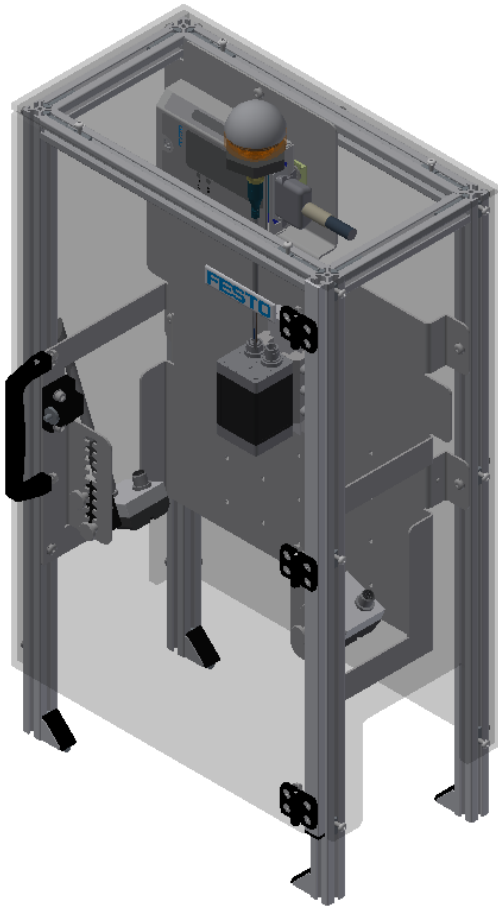



Illustration similar

The following MES-operations are available for the AM-CAM.

Operation number	Description
400	Camera check / Check part with camera
401	Check no fuse / camera check false if any fuse is detected
402	Check front fuse / true if the front fuse is detected
403	Check rear fuse / true if the rear fuse is detected
404	Check both fuses / true if both fuses are detected
405	Check part upside down / check part upside down

Operation Number (OpNo):  Short Description:

Description:    

Free Text (Web-Page):

Parameter

No.	Description	Low limit	High limit	Type	Value
1	camera program	0	0	changable	1
2	return value	0	0	on runtime	0
3	front red	0	5	changable	0
4	front green	0	5	changable	0
5	front blue	0	5	changable	0
6	middle red	0	5	changable	0
7	middle green	0	5	changable	0
8	middle blue	0	5	changable	0
9	back red	0	5	changable	0
10	back green	0	5	changable	0
11	back blue	0	5	changable	0

Operation Number (OpNo):  Short Description:

Description:    

Free Text (Web-Page):

Parameter

No.	Description	Low limit	High limit	Type	Value
1	camera program	1	6	on runtime	1
2	return value	0	0	on runtime	0

Operation Number (OpNo):  Short Description:

Description:    

Free Text (Web-Page):

Parameter

No.	Description	Low limit	High limit	Type	Value
1	camera program	1	6	on runtime	2
2	return value	0	0	on runtime	0

Operation Number (OpNo):  Short Description:

Description:    

Free Text (Web-Page):

Parameter

No.	Description	Low limit	High limit	Type	Value
1	camera program	1	6	on runtime	3
2	return value	0	0	on runtime	0

Operation Number (OpNo):  Short Description:

Description:    

Free Text (Web-Page):

Parameter

No.	Description	Low limit	High limit	Type	Value
1	camera program	1	6	on runtime	4
2	return value	0	0	on runtime	0

Operation Number (OpNo):  Short Description:

Description:    

Free Text (Web-Page):

Parameter

No.	Description	Low limit	High limit	Type	Value
1	camera program	1	6	on runtime	5
2	return value	0	0	on runtime	0

### 8.4.2 Default Parameter (CAM)

Parameter number	Description
1	<p><b>Program</b></p> <p>Program number to evaluate the camera picture</p> <p>Standard programs:</p> <ol style="list-style-type: none"> <li>1. Check no fuse assembled</li> <li>2. Check if PCB has front fuse</li> <li>3. Check if PCB has back fuse</li> <li>4. Check if PCB has both fuses</li> <li>5. Check if front covers right side up</li> <li>6. Not used</li> <li>7. Check for empty pallet</li> </ol>

## 9 Message texts and interactive error messages at the HMI

In general, there are three different reporting classes. These are designed as follows

- Message class 0 (displayed red in the message line)
  - the program is immediately stopped and the automatic mode is terminated
  - the cause of the error has to be fixed
  - Then acknowledge the fault and restart the station
- Message class 1 (displayed red in the message line)
  - the program and the automatic mode are stopped at the end of the cycle
  - the cause of the error has to be fixed
  - Then acknowledge the fault and restart the station
- Message class 2 (displayed yellow in the message line)
  - the program and the automatic mode are executed further
  - If the cause of the fault is fixed, the error is automatically acknowledged
- Note
  - Displayed on the HMI but not processed in MES

### 9.1 Message texts

Actual there are no message texts available.

## 9.2 Interactive error messages

### 9.2.1 Default operation

Interactive messages are displayed via a pop-up window at HMI

The Pop Up has three buttons.

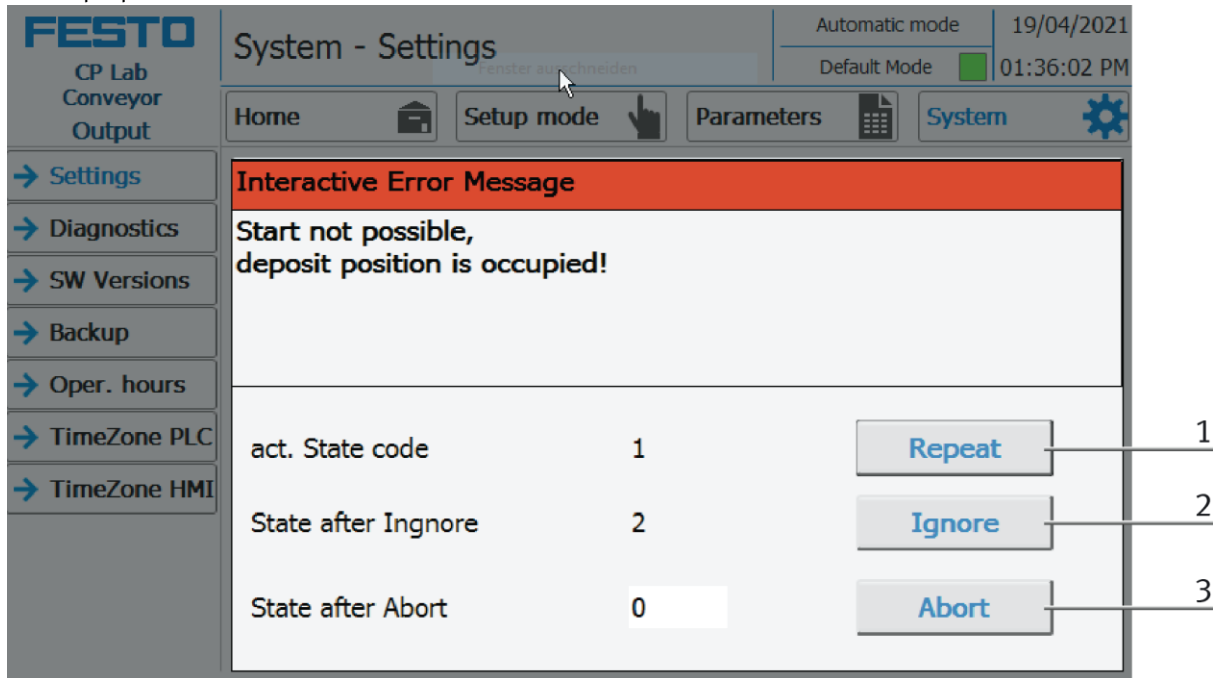

Example application module output - interactive error message in default mode

Position	Note
1	Repeat - An attempt is made to run the application again.
2	Ignore – The error status is ignored; the workpiece carrier receives the status code as indicated in the transition table in the "Initial status" column. The application is no longer executed.
3	Abort – The error status is ignored; the workpiece carrier receives the status code as shown in the input / output field next to the value displayed. This can be changed in this interactive error message window.

### 9.2.2 MES Operation

Interactive messages are displayed via a pop-up window at HMI

The Pop Up has four buttons.

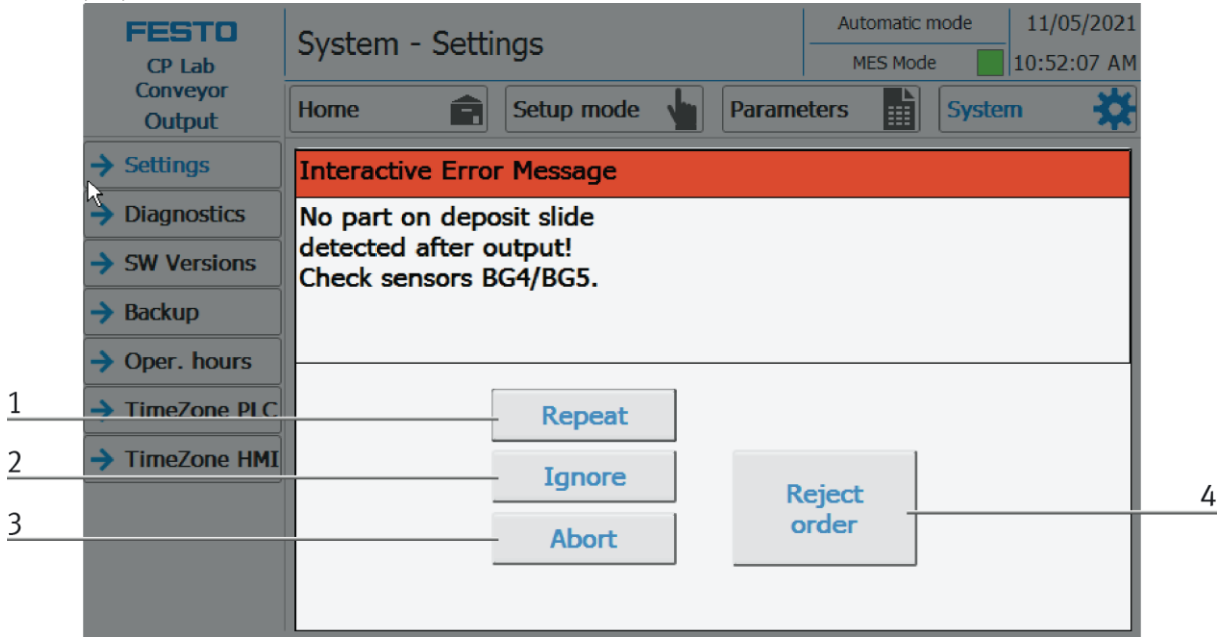

Example application module output - interactive error message in default mode

Position	Note
1	Repeat - An attempt is made to run the application again with the same parameters.
2	Ignore – The application is not executed, but is treated in the MES as if the order step had been executed without errors.
3	Abort – The application is no longer executed. In the MES, this order position is terminated with an error and canceled, depending on whether an error step has been defined or not.
4	Reject order - the application will not be executed. In the MES, the step of this order position is reset and restarted the next time the workpiece carrier arrives.



### 9.2.3 General

Value	Text	Fix error
100	Order aborted with errors!	Start order again

### 9.2.1 Application module camera

Value	Text	Fix error
1050	Camera not in online mode	
1051	Camera not ready	
5050	Quality check failed	
5051	No code found	

## 10 Spare part list

### 10.1 Electric parts

Description	Part number	Res.Ident	Use
K50L2RGB7Q	8125590	P1	Indication lamp Banner
SBSA-U-PF-R2C-FM-W	8143672	BX1	Camera (Sensopart V20C-ALL-P3-W-M-M2-L-90)
SBAL-C6-A-W	8031158	EA1	Light 1
SBAL-C6-A-W	8031158	EA2	Light 2
I/O Module	8027412	XD1	

## 11 Service and cleaning

The components and systems from Festo Didactic are maintenance-free.

At regular intervals you should have checked:

- the lenses of the optical sensors, fibre optics and reflectors
- the active surface of the proximity switch
- the entire station

can be cleaned with a soft, lint-free cloth or brush.

	<p style="text-align: right;"><b><i>NOTE</i></b></p> <p>Do not use aggressive or abrasive cleaners.</p>
---	---

Protective covers must not be cleaned with alcoholic cleaning agents, there is a risk of embrittlement.

## 12 Further information and updating

Further information and updates on the technical documentation of Festo Didactic components and systems can be found on the Internet at:

[www.ip.festo-didactic.com](http://www.ip.festo-didactic.com)



## 13 Disposal

	<p style="text-align: center;"><b><i>NOTE</i></b></p> <p>Electronic waste contains recyclable materials and must not be disposed of with the domestic waste. Bring electronic waste to a designated municipal collection point.</p>
---	---

**Festo Didactic SE**

Rechbergstraße 3  
73770 Denkendorf  
Germany



+49 711 3467-0



+49 711 34754-88500



[www.festo-didactic.com](http://www.festo-didactic.com)



[did@festo.com](mailto:did@festo.com)